



11017 INSTALLATION INSTRUCTIONS



Safety glasses should be worn at all times while installing this product.

YEARS: 2010-CURRENT

MAKE: LEXUS

MODEL: HS 250h

STYLE: SEDAN

WARNING: NEVER EXCEED YOUR VEHICLE MANUFACTURER'S RECOMMENDED TOWING CAPACITY





WEIGHT CARRYING:
TRAILER WEIGHT: 2,000 LBS.
TONGUE WEIGHT: 200 LBS.

WARNING:
WE RECOMMEND THE USE OF 18050 STABILIZING STRAPS FOR ALL NON-TRAILER (WHEEL-LESS) LOADS. PLEASE SEE THE CURT CATALOG OR VISIT US ONLINE AT WWW.CURTMFG.COM FOR FURTHER INFORMATION.

INSTALLATION TIME: 20 MIN.

THE INSTALL TIME LISTED IS FOR PROFESSIONAL INSTALLERS. IF YOU ARE HESITANT TO UNDERTAKE THIS TASK ON YOUR OWN, CONTACT AN AUTHORIZED CURT INSTALLER FOR ADDITIONAL ASSISTANCE.





INSTALLATION REQUIRES:

 RATCHET	 TORQUE WRENCH	 9" SOCKET EXTENSION
 10mm 17mm 19mm SOCKET	 AVIATION SHEARS	

INSTALLATION TIPS:

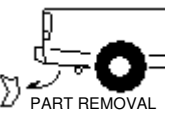
- BEFORE YOU BEGIN INSTALLATION, READ ALL INSTRUCTIONS THOROUGHLY.
- TO EASE INSTALLATION, 2 PEOPLE MAY BE REQUIRED.
- USING PROPER TOOLS WILL GREATLY IMPROVE THE QUALITY OF THE INSTALL AND REDUCE THE TIME REQUIRED.
- NEED HELP OR HAVE SOME QUESTIONS? CALL TECHNICAL SUPPORT AT 800.798.0813

LEVEL OF DIFFICULTY: MODERATE

EASY	MODERATE	HARD
	TOW LOOP REMOVAL	
	LOWER EXHAUST	
	TRIM HEAT SHIELD	
	NO DRILL	

VEHICLE PHOTO:



REPRESENTATIVE PHOTO

HITCH ILLUSTRATION:

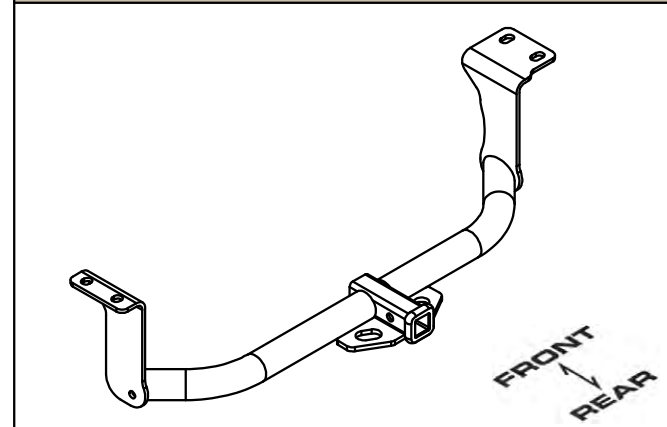

MAKE SURE YOUR HITCH MATCHES

PERIODICALLY CHECK THIS RECEIVER HITCH TO ENSURE ALL FASTENERS ARE TIGHT AND ALL STRUCTURAL COMPONENTS ARE SOUND

CURT Manufacturing Inc. warrants this product to be free of defects in material and/or workmanship at the time of retail purchase by the original purchaser. If the product is found to be defective, Curt Manufacturing Inc. may repair or replace the product at their option, when the product is returned, prepaid, with proof of purchase. Alteration to, misuse of, or improper installation of this product voids the warranty. Curt Manufacturing Inc.'s liability is limited to repair or replacement of products found to be defective, and specifically excludes liability for incidental or consequential loss or damage.

For more information log onto www.curtmfg.com, & for helpful towing tips log onto www.hitchinfo.com

INSTALLATION WALKTHROUGH:

Parts List			
ITEM	QTY	PART NUMBER	DESCRIPTION
1	4	M12 - 1.25 x 40 HEX	HEX BOLT
2	4	1/2"	CONICAL TOOTHED WASHER

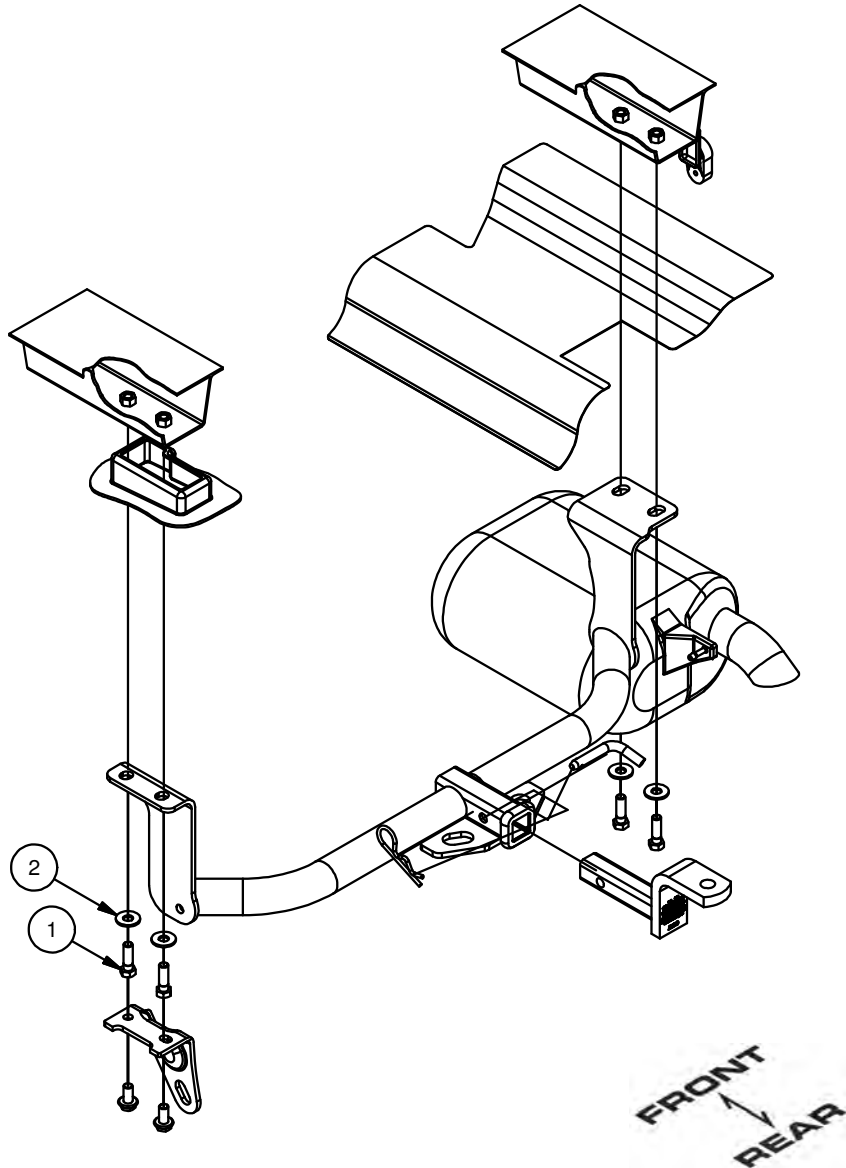

1. Remove (4) exhaust hangers and lower the exhaust, support as needed to prevent damage.



RUBBER ISOLATOR REMOVAL DIAGRAM

This technique can be used if an Exhaust Hanger Removal Pliers is not available.

Using a 5/8" open end wrench, slide the wrench up to the rubber isolator, cradling the hanger rod as shown. Next place the flat edge of a pry bar between the wrench and the hanger stop or hanger rod. Then simply rotate the pry bar toward the wrench to remove the rubber isolator.

Note: Using a spray lubricant or soapy water on the hanger rod and the rubber isolator helps removal.



2. Using a 10mm socket remove (3) fasteners and remove heat shield. Heat shield will be trimmed and reinstalled in Step 4.

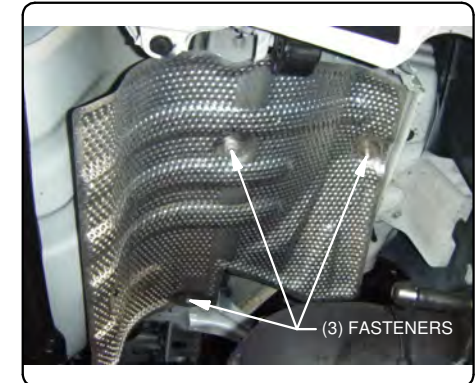

INSTALLATION WALKTHROUGH:

- Using a 17mm socket and extension remove (2) bolts and tow loop. Return tow loop and bolts to owner.



- Mark heat shield for trimming and confirm fit. Trim heat shield using aviation shears and reinstall.

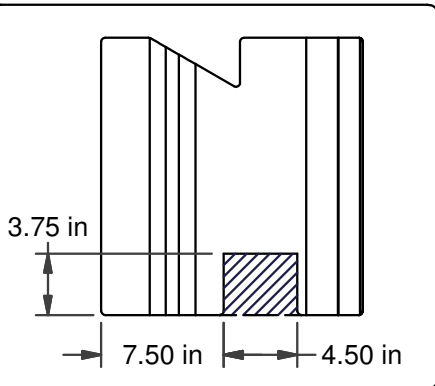

- Raise the driver side plate through the tow loop cut out and up against the frame rail. Secure using M12 - 1.25 X 40mm bolts and 1/2" conical toothed washers into existing weldnuts.

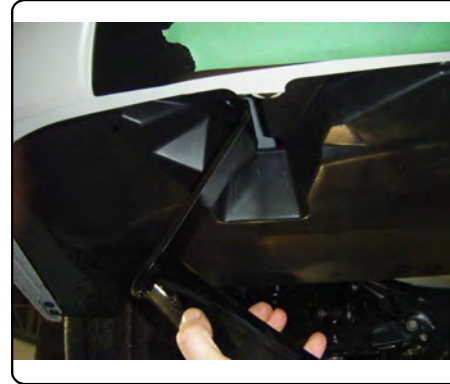

- Raise the passenger side plate against the frame rail and secure with M12 - 1.25 X 40mm bolts and 1/2" conical toothed washers into existing weldnuts.



INSTALLATION WALKTHROUGH:

7. Torque all 12mm fasteners to 86 ft-lbs. Raise exhaust and reinstall exhaust hangers.



INSTALLATION IS NOW COMPLETE

11017

LEXUS HS 250h

11/26/2012

PAGE 1 OF 2

GROSS LOAD CAPACITY WHEN USED AS A WEIGHT CARRYING HITCH: 2,000 LBS. TRAILER WEIGHT & 200 LBS. TONGUE WEIGHT.

DO NOT EXCEED VEHICLE MANUFACTURER'S RECOMMENDED TOWING CAPACITY.

WARNING: ALL NON-TRAILER LOADS APPLIED TO THIS PRODUCT MUST BE SUPPORTED BY 18050 STABILIZING STRAPS.

** FAILURE TO PROPERLY SUPPORT NON-TRAILER LOADS WILL VOID PRODUCT WARRANTY**

HAVING INSTALLATION QUESTIONS? CALL TECHNICAL SUPPORT AT 1-800-798-0813

Parts List			
ITEM	QTY	PART NUMBER	DESCRIPTION
1	4	M12 - 1.25 x 40 HEX	HEX BOLT
2	4	1/2"	CONICAL TOOTHED WASHER

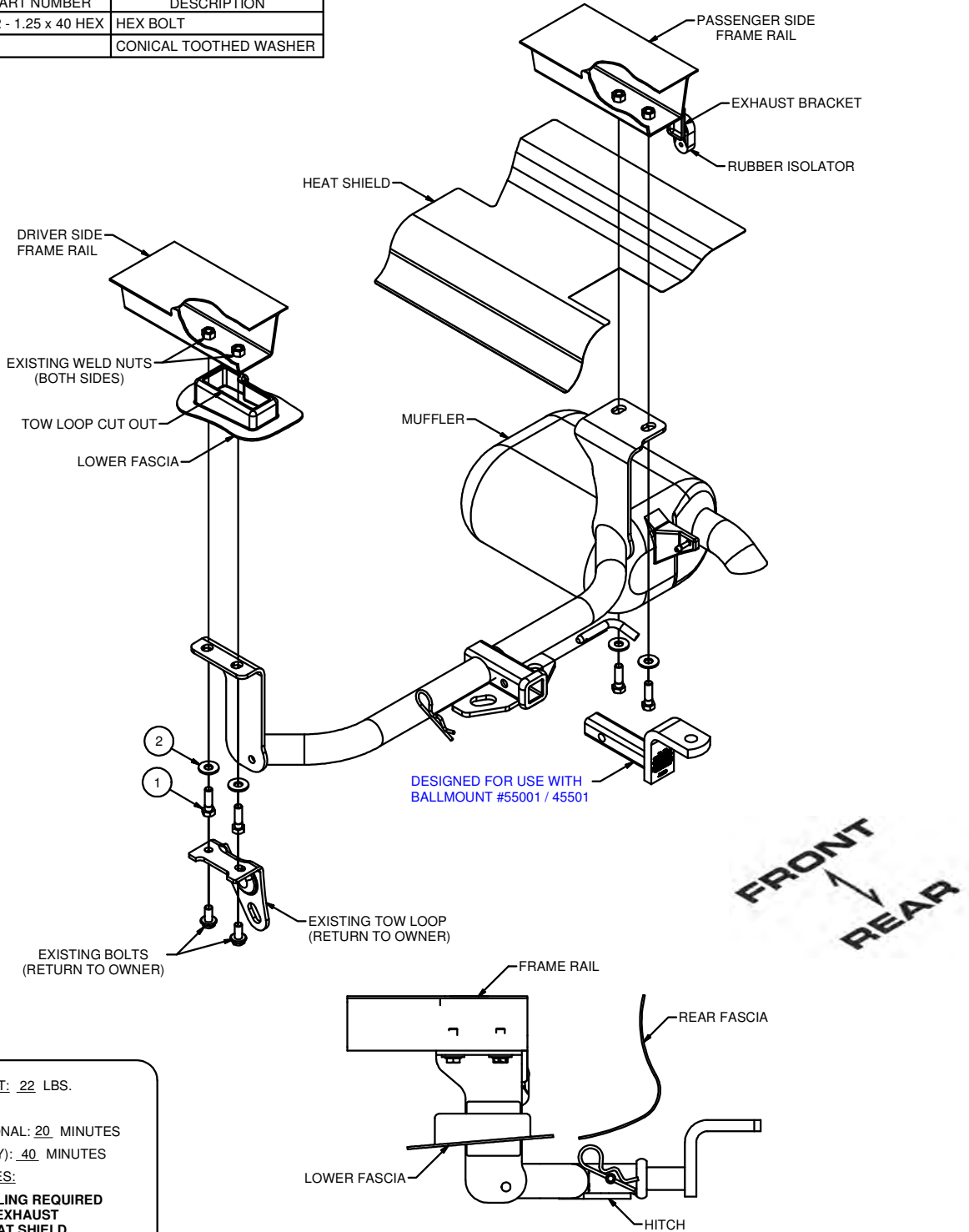

HITCH WEIGHT: 22 LBS.
 INSTALL TIME
 PROFESSIONAL: 20 MINUTES
 NOVICE (DIY): 40 MINUTES
 INSTALL NOTES:
 - NO DRILLING REQUIRED
 - LOWER EXHAUST
 - TRIM HEAT SHIELD
 - REMOVE TOW LOOP

PERIODICALLY CHECK THIS RECEIVER HITCH TO ENSURE THAT ALL FASTENERS ARE TIGHT AND THAT ALL STRUCTURAL COMPONENTS ARE SOUND.

Curt Manufacturing Inc., warrants this product to be free of defects in material and/or workmanship at the time of retail purchase by the original purchaser. If the product is found to be defective, Curt Manufacturing Inc., may repair or replace the product, at their option, when the product is returned, prepaid, with proof of purchase. Alteration to, misuse of, or improper installation of this product voids the warranty. Curt Manufacturing Inc.'s liability is limited to repair or replacement of products found to be defective, and specifically excludes liability for incidental or consequential loss or damage.

HAVING INSTALLATION QUESTIONS? CALL TECHNICAL SUPPORT AT 1-800-798-0813

TOOLS REQUIRED

RATCHET
TORQUE WRENCH
9" EXTENSION
AVIATION SHEARS
19mm SOCKET
17mm SOCKET
10mm SOCKET

RUBBER ISOLATOR REMOVAL DIAGRAM

This technique can be used if and Exhaust Hanger Removal Pliers is not available.

Using a 5/8" open end wrench, slide the wrench up to the rubber isolator, cradling the hanger rod as shown. Next place the flat edge of a pry bar between the wrench and the hanger stop or hanger rod. Then simply rotate the pry bar toward the wrench to remove the rubber isolator.

Note: Using a spray lubricant or soapy water on the hanger rod and the rubber isolator helps removal.

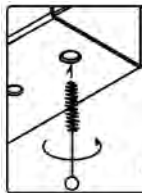

WELDNUT CLEANING

To remove debris from weldnuts in frame, spray lubricant or compressed air into hole. For heavy debris, use a small wire brush. (Be careful not to damage threads).

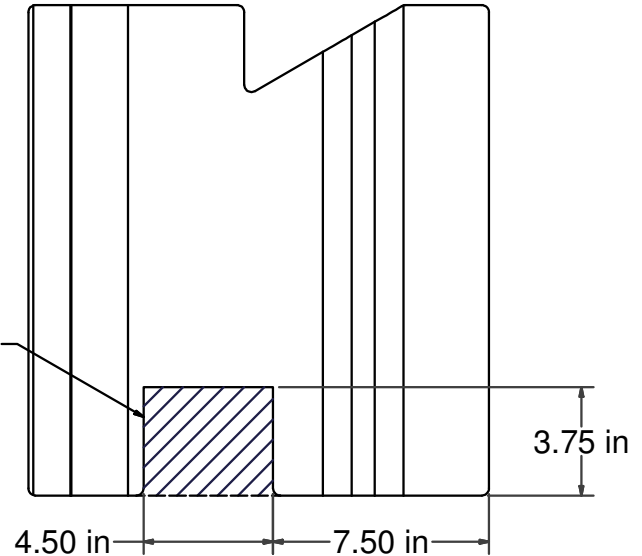

NOTE: DIMENSIONS ARE APPROXIMATE. CONFIRM FIT PRIOR TO TRIMMING

HEAT SHIELD TRIM DETAIL

INSTALLATION STEPS

1. Remove (4) exhaust hangers and lower the exhaust, support as needed to prevent damage. SEE RUBBER ISOLATOR REMOVAL DIAGRAM
2. Remove (3) fasteners and remove heat shield.
3. Remove (2) existing bolts from tow loop and remove tow loop. Return tow loop and bolts to owner.
NOTE: Access bolts through tow loop cut out in lower fascia.
4. Mark heat shield for trimming and confirm the fit. Trim heat shield using aviation shears and reattach.
5. Raise the driver side plate through the tow loop cut out and up against the frame rail. Secure using M12 - 1.25 X 40mm bolts and 1/2" conical toothed washers into existing weldnuts as shown.
6. Raise the passenger side plate against the frame rail and secure using M12 - 1.25 X 40mm bolts and 1/2" conical toothed washers into existing weldnuts as shown.
7. Torque all 12mm fasteners to 86 ft-lbs.
8. Raise exhaust and reinstall exhaust hangers.

PERIODICALLY CHECK THIS RECEIVER HITCH TO ENSURE THAT ALL FASTENERS ARE TIGHT AND THAT ALL STRUCTURAL COMPONENTS ARE SOUND.