



Safety glasses should be worn at all times while installing this product.

YEARS: 2011-2014
2011-2015

MAKE: HYUNDAI
KIA

MODEL: SONATA (INCLUDING BLUE DRIVER)
OPTIMA

STYLE: SEDAN
SEDAN

WARNING: NEVER EXCEED YOUR VEHICLE MANUFACTURER'S RECOMMENDED TOWING CAPACITY

WEIGHT CARRYING: TRAILER WEIGHT: 2,000 LBS.
TONGUE WEIGHT: 200 LBS.

WARNING:
WE RECOMMEND THE USE OF 18050 STABILIZING STRAPS FOR ALL NON-TRAILER (WHEEL-LESS) LOADS. PLEASE SEE THE CURT CATALOG OR VISIT US ONLINE AT WWW.CURTMFG.COM FOR FURTHER INFORMATION.

PRO INSTALL TIME: 20 MIN.
NOVICE INSTALL TIME: 40 MIN.

IF YOU ARE HESITANT TO UNDERTAKE THIS TASK ON YOUR OWN, CONTACT AN AUTHORIZED CURT INSTALLER FOR ADDITIONAL ASSISTANCE.

INSTALLATION REQUIRES:

	10 mm 3/4 in	SPRAY LUBRICANT
		SAFETY GLASSES

INSTALLATION TIPS:

- BEFORE YOU BEGIN INSTALLATION, READ ALL INSTRUCTIONS THOROUGHLY.
- TO EASE INSTALLATION, 2 PEOPLE MAY BE REQUIRED.
- USING PROPER TOOLS WILL GREATLY IMPROVE THE QUALITY OF THE INSTALL AND REDUCE THE TIME REQUIRED.
- NEED HELP OR HAVE SOME QUESTIONS? CALL TECHNICAL SUPPORT AT 800.798.0813

LEVEL OF DIFFICULTY: EASY

EASY	MODERATE	CHALLENGING
	- REMOVE RUBBER EXHAUST HANGERS	
	- FISHWIRE HARDWARE	
	- REMOVE HEAT SHIELD(S)	
	- MAY REQUIRE HOLE ENLARGEMENT	
	- TRIM UNDERBODY PANEL (IF PRESENT)	

VEHICLE PHOTO:



REPRESENTATIVE PHOTO

HITCH ILLUSTRATION:

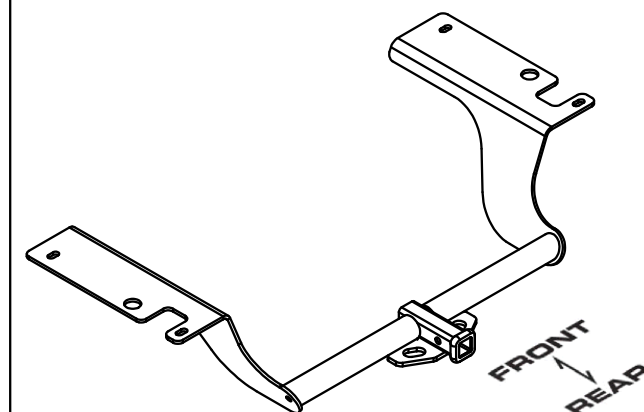

MAKE SURE YOUR HITCH MATCHES

PERIODICALLY CHECK THIS RECEIVER HITCH TO ENSURE ALL FASTENERS ARE TIGHT AND ALL STRUCTURAL COMPONENTS ARE SOUND

CURT Manufacturing LLC. warrants this product to be free of defects in material and/or workmanship at the time of retail purchase by the original purchaser. If the product is found to be defective, CURT Manufacturing LLC. may repair or replace the product at their option, when the product is returned, prepaid, with proof of purchase. Alteration to, misuse of, or improper installation of this product voids the warranty. CURT Manufacturing LLC.'s liability is limited to repair or replacement of products found to be defective, and specifically excludes liability for incidental or consequential loss or damage.

For more information log onto www.curtmfg.com, & for helpful towing tips log onto www.hitchinfo.com

INSTALLATION WALKTHROUGH:

Parts List			
ITEM	QTY	PART NUMBER	DESCRIPTION
1	4	1/2-13 x 1 1/4	CARRIAGE BOLT
2	4	CM-SP6	.250 x 1.00 x 3.00" SQUARE HOLE SPACER
3	4	HFN 1213	HEX FLANGE NUT
4	2	1_2 x 30 FISHWIRE	1/2" x 30" FISHWIRE

TRIM DIAGRAM (MODELS WITH UNDERBODY PANEL)

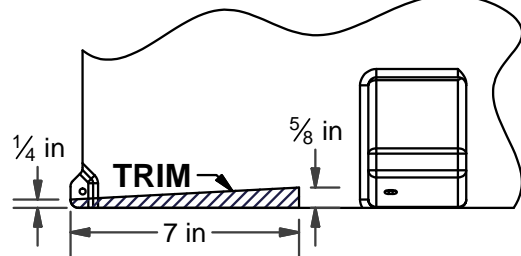

NOTE: TRIM DIMENSIONS ARE APPROXIMATE. CHECK FIT PRIOR TO COMPLETING TRIM.

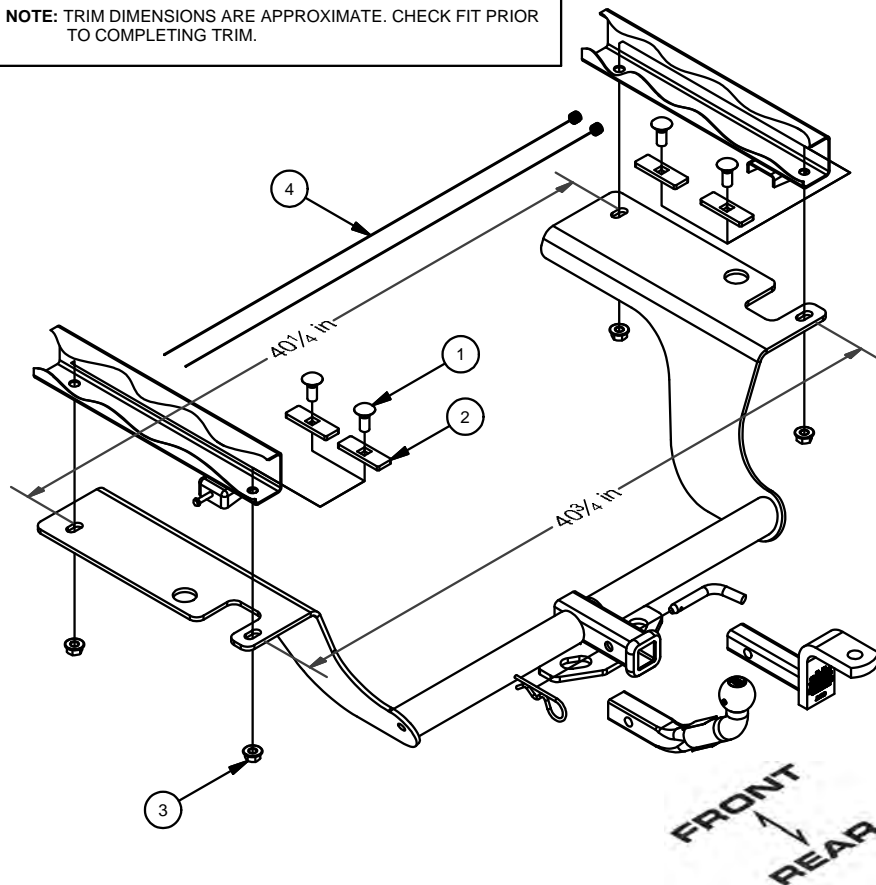

1. Remove rubber exhaust hangers and lower exhaust. (See RUBBER ISOLATOR REMOVAL DIAGRAM below)
Note: Be sure to support exhaust to prevent damage.

RUBBER ISOLATOR REMOVAL DIAGRAM

This technique can be used if an Exhaust Hanger Removal Pliers is not available.

Using a 5/8" open end wrench, slide the wrench up to the rubber isolator, cradling the hanger rod as shown. Next place the flat edge of a pry bar between the wrench and the hanger stop or hanger rod. Then simply rotate the pry bar toward the wrench to remove the rubber isolator.

Note: Using a spray lubricant or soapy water on the hanger rod and the rubber isolator helps removal.

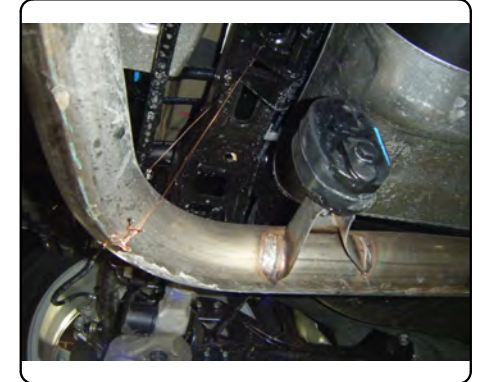

2. Remove heat shield(s) by removing (4) fasteners and remove plastic underbody panel (if present) by removing (6) fasteners.



INSTALLATION WALKTHROUGH:

3. Remove (2) pads from each frame rail and discard. These pads cover holes which will be used to mount hitch. Check for fishwire access between the bumper and rear-most part of frame. If access is not present you will have to enlarge the forward-most hole to allow 1/2" bolts and spacers to pass through.

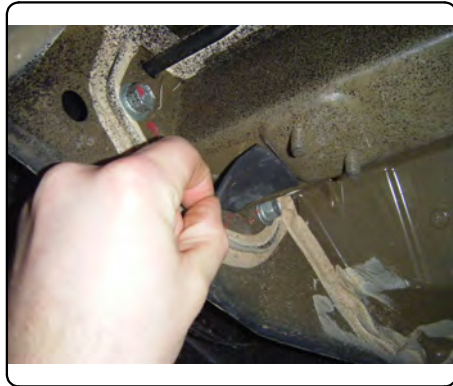

4. Fishwire and/or reverse fishwire 1/2" bolts and spacers into position on driver and passenger side of vehicle.

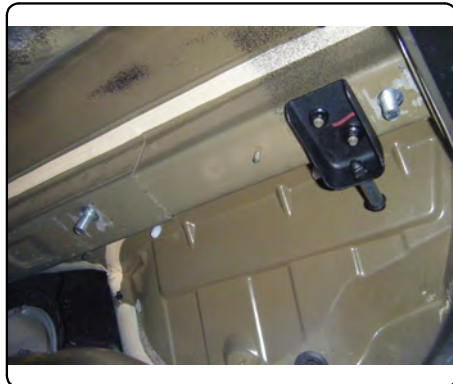

5. Raise hitch into position and attach to frame using 1/2" flange nuts.

NOTE: Be careful not to push hardware into frame when raising hitch into position.

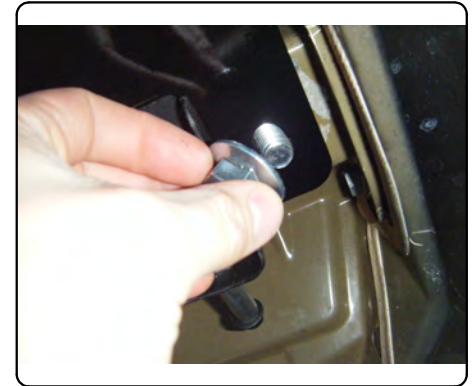

7. Torque all 1/2" hardware to 110 ft-lbs. Reinstall heat shield(s) and leave rear most fastener off, may have to slot front hole in heat shield. Raise exhaust back into position. If underbody panel was present, trim and reinstall. (See TRIM DIAGRAM on page 2)
Install is complete.



11025

HYUNDAI SONATA (INCLUDING BLUE DRIVE) & KIA OPTIMA

1/6/2016

GROSS LOAD CAPACITY WHEN USED AS A WEIGHT CARRYING HITCH: 2,000 LBS. TRAILER WEIGHT & 200 LBS. TONGUE WEIGHT.

DO NOT EXCEED VEHICLE MANUFACTURER'S RECOMMENDED TOWING CAPACITY.

WARNING: ALL NON-TRAILER LOADS APPLIED TO THIS PRODUCT MUST BE SUPPORTED BY 18050 STABILIZING STRAPS.

** FAILURE TO PROPERLY SUPPORT NON-TRAILER LOADS WILL VOID PRODUCT WARRANTY**

HAVING INSTALLATION QUESTIONS? CALL TECHNICAL SUPPORT AT 1-800-798-0813

Parts List			
ITEM	QTY	PART NUMBER	DESCRIPTION
1	4	1/2-13 x 1 1/4	CARRIAGE BOLT
2	4	CM-SP6	.250 x 1.00 x 3.00" SQUARE HOLE SPACER
3	4	HFN 1213	HEX FLANGE NUT
4	2	1_2 x 30 FISHWIRE	1/2" x 30" FISHWIRE

TOOLS REQUIRED
RATCHET
10 mm SOCKET
3/4 in SOCKET
PRY BAR
TORQUE WRENCH

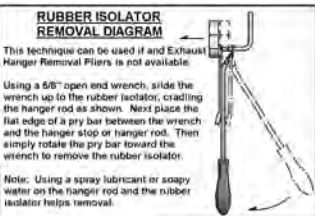
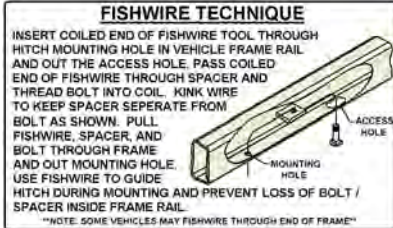
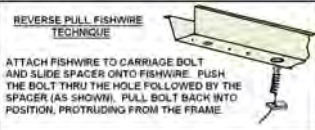

PADS LOCATED OVER HOLES
NOTE: YOU MAY NEED TO ENLARGE THIS HOLE, BOTH SIDES.

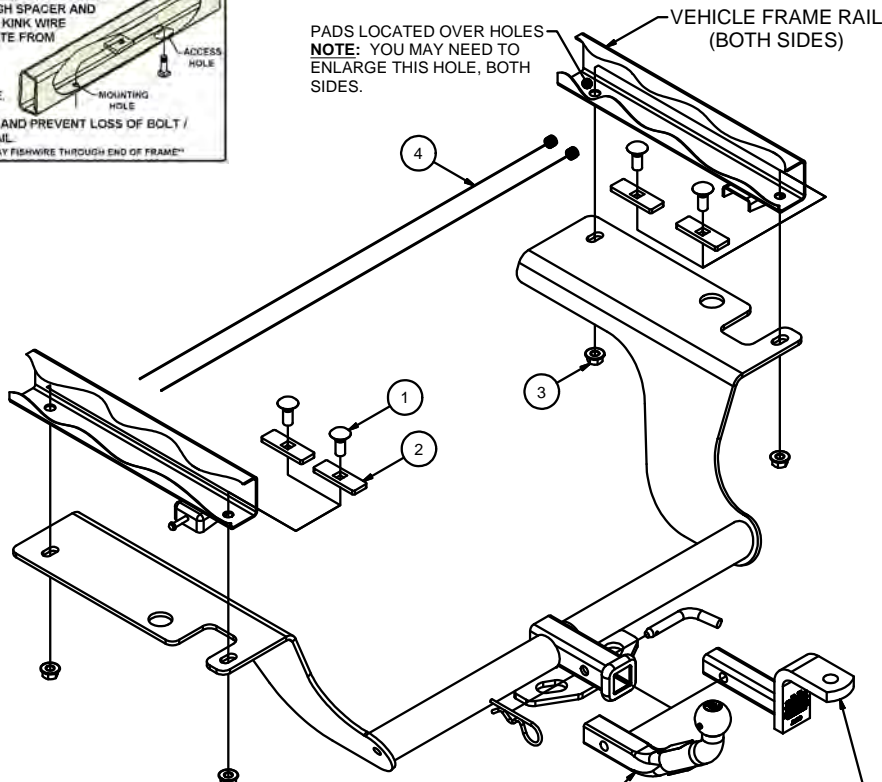

EURO MOUNT OPTION AVAILABLE #45571 (1-7/8" BALL) #45572 (2" BALL) DESIGNED FOR USE WITH BALLMOUNT #D-55001 / 45501

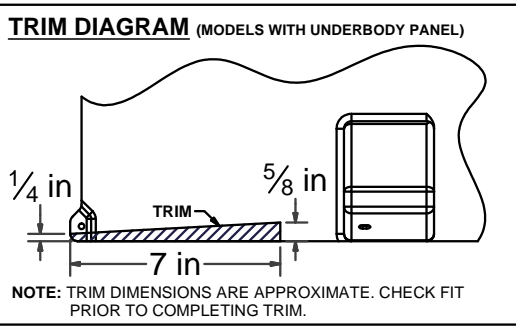

HITCH WEIGHT: 34 LBS.
INSTALL TIME
PROFESSIONAL: 20 MINUTES
NOVICE (DIY): 40 MINUTES
INSTALL NOTES:
-MAY REQUIRE HOLE ENLARGEMENT
-FISHWIRE HARDWARE
-LOWER EXHAUST
-REMOVE HEAT SHIELD

INSTALLATION STEPS

1. Remove rubber exhaust hangers and lower exhaust. (See RUBBER ISOLATOR REMOVAL DIAGRAM)
Note: Be sure to support exhaust to prevent damage.
2. Remove heat shield(s) by removing (4) fasteners and remove plastic underbody panel (if present) by removing (6) fasteners.
3. Remove (2) pads from each frame rail and discard. These pads cover holes which will be used to mount hitch.
4. Check for fishwire access between the bumper and rear-most part of frame. If access is not present you will have to enlarge the forward-most hole to allow 1/2" bolts and spacers to pass through.
5. Fishwire 1/2" bolts and spacers into position. (See FISHWIRE TECHNIQUE)
6. Raise hitch into position and attach to frame using 1/2" flange nuts.
7. Torque all 1/2" hardware to 110 ft-lbs. Reinstall heat shield(s) and leave rear most fastener off, may have to slot front hole in heat shield. Raise exhaust back into position. If underbody panel was present, trim and reinstall. (See TRIM DIAGRAM)

PERIODICALLY CHECK THIS RECEIVER HITCH TO ENSURE THAT ALL FASTENERS ARE TIGHT AND THAT ALL STRUCTURAL COMPONENTS ARE SOUND.

Curt Manufacturing Inc., warrants this product to be free of defects in material and/or workmanship at the time of retail purchase by the original purchaser. If the product is found to be defective, Curt Manufacturing Inc., may repair or replace the product, at their option, when the product is returned, prepaid, with proof of purchase. Alteration to, misuse of, or improper installation of this product voids the warranty. Curt Manufacturing Inc.'s liability is limited to repair or replacement of products found to be defective, and specifically excludes liability for incidental or consequential loss or damage.