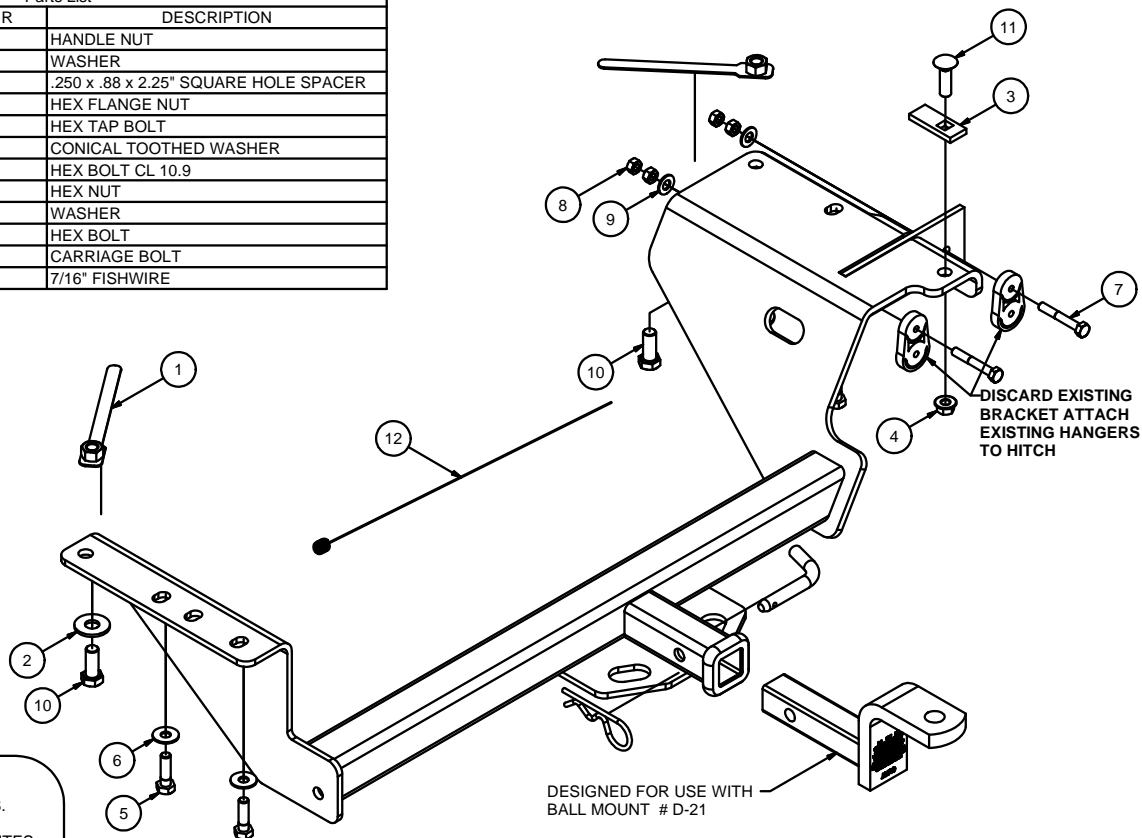

11027**'95-'00 CHRYSLER CIRRUS / '95-'06 DODGE STRATUS (sedan)
'95-'00 PLYMOUTH BREEZE****10/12/2012****GROSS LOAD CAPACITY WHEN USED AS A WEIGHT CARRYING HITCH: 2000 LBS. TRAILER WEIGHT & 200 LBS. TONGUE WEIGHT.
DO NOT EXCEED VEHICLE MANUFACTURER'S RECOMMENDED TOWING CAPACITY.**

Parts List			
ITEM	QTY	PART NUMBER	DESCRIPTION
1	2	1/2-13	HANDLE NUT
2	2	1/2"	WASHER
3	1	CM-SP2	.250 x .88 x 2.25" SQUARE HOLE SPACER
4	1	7/16-14	HEX FLANGE NUT
5	3	M10 - 1.5 x 35mm	HEX TAP BOLT
6	3	3/8"	CONICAL TOOTHED WASHER
7	2	M8 - 1.25 x 55mm	HEX BOLT CL 10.9
8	4	M8-1.25	HEX NUT
9	2	3/8"	WASHER
10	2	1/2-13 x 1 1/4	HEX BOLT
11	1	7/16-14 x 1 1/2	CARRIAGE BOLT
12	1	7_16 FISHWIRE	7/16" FISHWIRE

HITCH WEIGHT: 37 LBS.INSTALL TIME: 30 MINUTES

INSTALL NOTES:

DRILLING REQ.**INSTALLATION STEPS**

- 1) Remove tie-down hook on driver's side frame rail. Note: reinstall two of the fasteners in the side of the frame.
- 2) Lower exhaust system by removing two 8mm bolts and disconnecting the exhaust hanger bracket from the frame rail and remove ground strap. Detach the rubber exhaust hanger by prying it off the exhaust hanger bracket (discard bracket). Disconnect the rubber exhaust hanger forward of the muffler.
- 3) Remove the 10mm bumper bracket bolt on the bottom of the passenger side frame rail.
- 4) Raise hitch into position and loosely install the three 10 mm bolts provided into existing weldnuts.
- 5) Using the hitch as a template drill 1/2" holes in the frame rail at the forward attachment points on each side and at the rear attachment on the passenger side.
- 6) Install 7/16 fasteners as shown using the fishwire tool.
- 7) Using access hole in frame install handle nut assembly as shown above
- 8) Raise exhaust system into position, and install 8mm X 55mm bolt and fasteners. Jam nuts together to prevent from loosening. Reattach forward rubber exhaust hanger and reinstall ground strap.
- 9) Return tie-down hook, tie-down fasteners, exhaust hanger bracket, 10mm & 8mm fasteners to vehicle owner, for reattachment in case hitch is removed.
- 10) Torque all 10mm hardware to 45 ft.-lb, 7/16" hardware to 70 ft.-lb and all 1/2" hardware to 110 ft.-lb.

PERIODICALLY CHECK THIS RECEIVER HITCH TO ENSURE THAT ALL FASTENERS ARE TIGHT AND THAT ALL STRUCTURAL COMPONENTS ARE SOUND.

Curt Manufacturing Inc., warrants this product to be free of defects in material and/or workmanship at the time of retail purchase by the original purchaser. If the product is found to be defective, Curt Manufacturing Inc., may repair or replace the product, at their option, when the product is returned, prepaid, with proof of purchase. Alteration to, misuse of, or improper installation of this product voids the warranty. Curt Manufacturing Inc.'s liability is limited to repair or replacement of products found to be defective, and specifically excludes liability for incidental or consequential loss or damage.