



11033 INSTALLATION INSTRUCTIONS



Safety glasses should be worn at all times while installing this product.

YEARS: 2007-2010

MAKE: BMW

MODEL: 328xi & 335xi

(GAS MODELS WITH SINGLE MUFFLER ONLY)

STYLE: SEDAN

WARNING: NEVER EXCEED YOUR VEHICLE MANUFACTURER'S RECOMMENDED TOWING CAPACITY

WEIGHT CARRYING:
 TRAILER WEIGHT: 2,000 LBS.
 TONGUE WEIGHT: 200 LBS.

WARNING:
 WE RECOMMEND THE USE OF 18050 STABILIZING STRAPS FOR ALL NON-TRAILER (WHEEL-LESS) LOADS. PLEASE SEE THE CURT CATALOG OR VISIT US ONLINE AT WWW.CURTMFG.COM FOR FURTHER INFORMATION.

INSTALLATION TIME: 30 MIN.

THE INSTALL TIME LISTED IS FOR PROFESSIONAL INSTALLERS. IF YOU ARE HESITANT TO UNDERTAKE THIS TASK ON YOUR OWN, CONTACT AN AUTHORIZED CURT INSTALLER FOR ADDITIONAL ASSISTANCE.

INSTALLATION REQUIRES:

 RATCHET	 8mm 10mm 11/16" 1/2" SOCKET	 BOXED END WRENCH 18mm & 5/8"
 TAPE MEASURE	 MARKER	 ROTARY TOOL WITH SMALL DISK GRINDER
 SAFETY GLASSES		

INSTALLATION TIPS:

1. BEFORE YOU BEGIN INSTALLATION, READ ALL INSTRUCTIONS THOROUGHLY.
2. TO EASE INSTALLATION, 2 PEOPLE MAY BE REQUIRED.
3. USING PROPER TOOLS WILL GREATLY IMPROVE THE QUALITY OF THE INSTALL AND REDUCE THE TIME REQUIRED.
4. NEED HELP OR HAVE SOME QUESTIONS? CALL TECHNICAL SUPPORT AT 800.798.0813

LEVEL OF DIFFICULTY: MODERATE

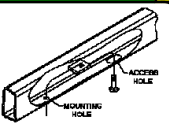
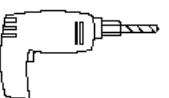
EASY	MODERATE	HARD
	FISHWIRE HARDWARE	
	DRILLING REQUIRED ON SOME MODELS	

VEHICLE PHOTO:

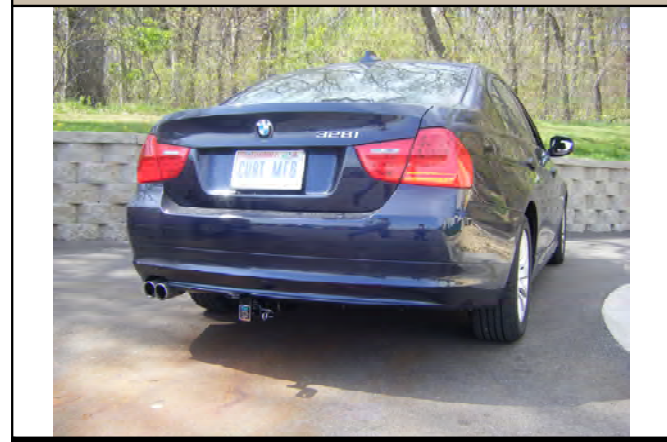

REPRESENTATIVE PHOTO

HITCH ILLUSTRATION:

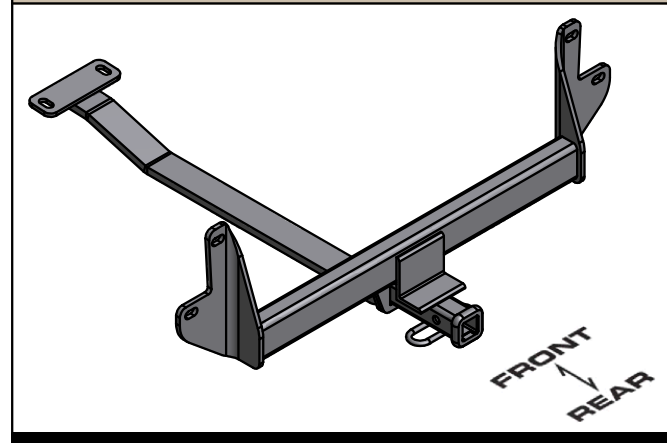

MAKE SURE YOUR HITCH MATCHES

PERIODICALLY CHECK THIS RECEIVER HITCH TO ENSURE ALL FASTENERS ARE TIGHT AND ALL STRUCTURAL COMPONENTS ARE SOUND

CURT Manufacturing Inc. warrants this product to be free of defects in material and/or workmanship at the time of retail purchase by the original purchaser. If the product is found to be defective, Curt Manufacturing Inc. may repair or replace the product at their option, when the product is returned, prepaid, with proof of purchase. Alteration to, misuse of, or improper installation of this product voids the warranty. Curt Manufacturing Inc.'s liability is limited to repair or replacement of products found to be defective, and specifically excludes liability for incidental or consequential loss or damage.

For more information log onto www.curtmfg.com, & for helpful towing tips log onto www.hitchinfo.com

INSTALLATION WALKTHROUGH:

Parts List			
ITEM	QTY	PART NUMBER	DESCRIPTION
1	16	7/16	WASHER
2	2	7/16-14 x 1 1/4	HEX BOLT
3	2	7/16-14	HEX FLANGE NUT
4	2	1/2-13 x 1 1/2	CARRIAGE BOLT
5	2	HFN 1213	HEX FLANGE NUT
6	2	CM-SP6	.250 x 1.00 x 3.00" SQUARE HOLE SPACER
7	2	1_2 FISHWIRE	1/2" FISHWIRE

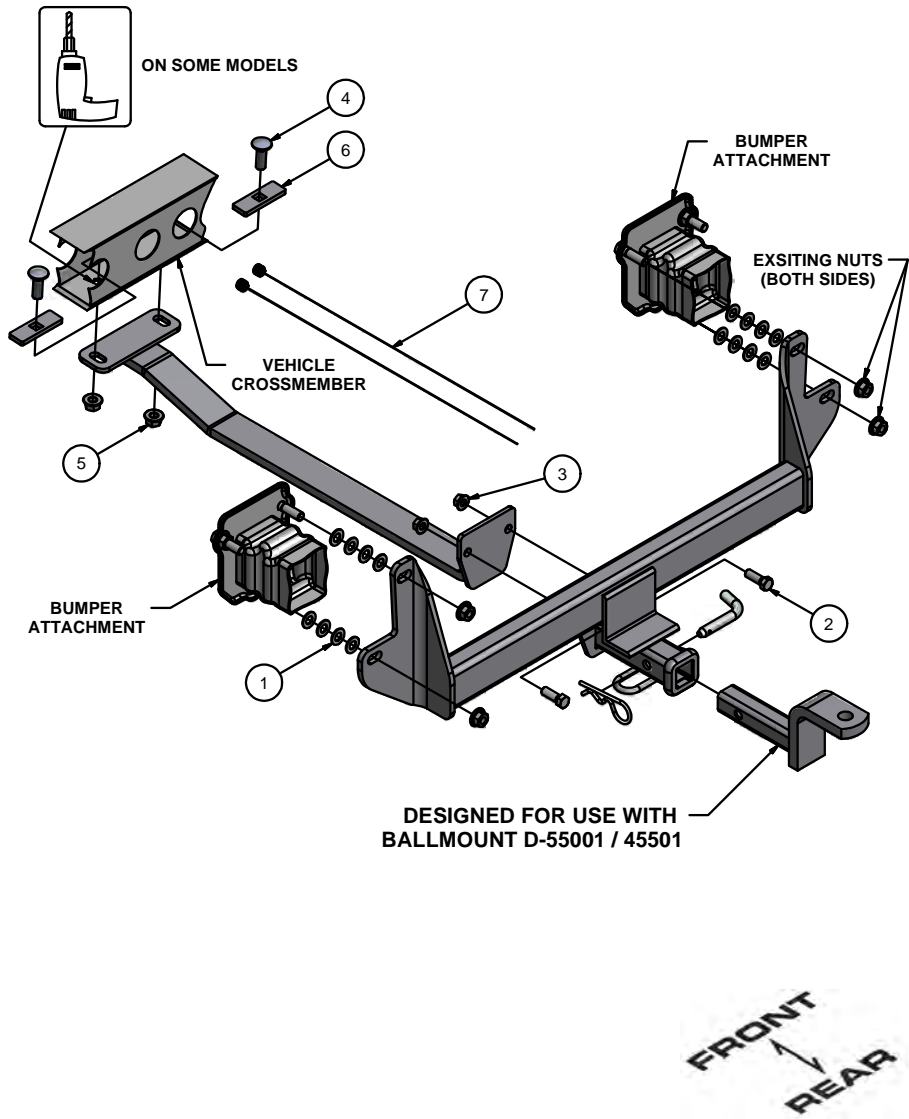

1. Remove (14) fasteners which secure (2) underbody panels. These will be re-installed in STEP 10.

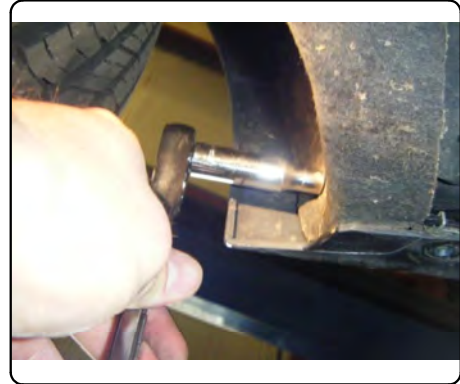
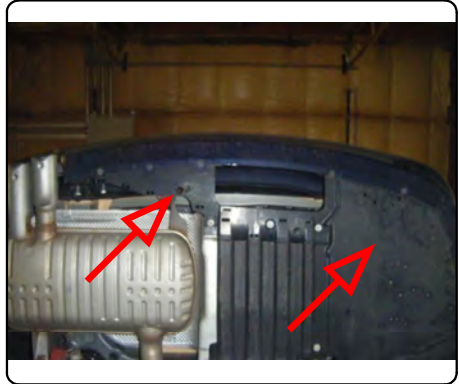

2. Remove (2) 12mm nuts from each bumper attachment. These will be re-used in STEP 4.



INSTALLATION WALKTHROUGH:

3. Place (4) 7/16" washers on each stud which a nut was removed from in STEP 2.



4. Lift the hitch into position over studs and secure with existing 12mm flange nuts.



5. Fishwire 1/2" carriage bolts and SP-6 spacers into vehicle crossmember. (See FISHWIRE TECHNIQUE below) Note: If holes are not present, use mounting strap as a template to mark & drill 17/32" holes.

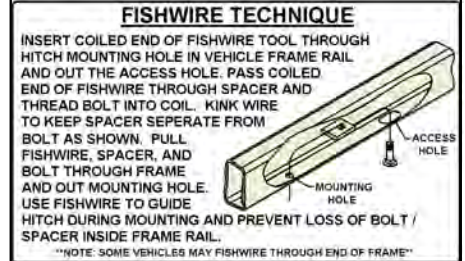

6. Raise mounting strap into position and attach to vehicle crossmember with 1/2" flange nuts.



INSTALLATION WALKTHROUGH:

7. Attach mounting strap to the hitch using 7/16" fasteners.



8. Torque all 7/16" hardware to 70 ft-lbs, 12mm hardware to 82 ft-lbs, and 1/2" hardware to 110 ft-lbs.



9. Trim (1) underbody panel. (See TRIM DIAGRAM below)

TRIM DIAGRAM

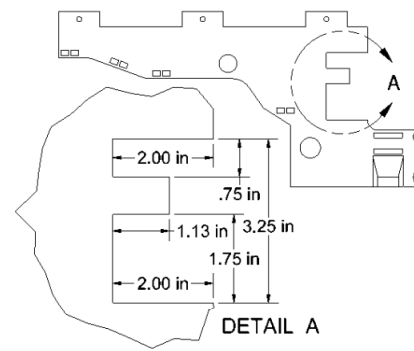

10. Re-install both underbody panels.

Install is complete.

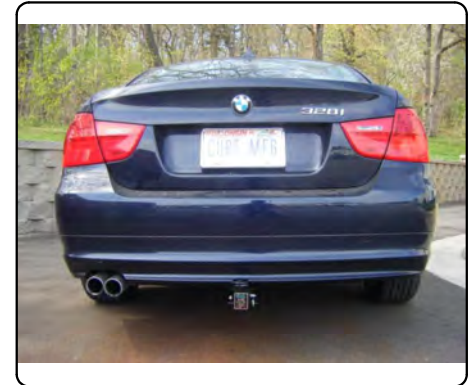

11033

BMW 325i, 328xi & 335xi AWD SEDAN

(GAS MODELS WITH
SINGLE MUFFLER ONLY)

11/12/2012

GROSS LOAD CAPACITY WHEN USED AS A WEIGHT CARRYING HITCH: 2,000 LBS. TRAILER WEIGHT & 200 LBS. TONGUE WEIGHT.

DO NOT EXCEED VEHICLE MANUFACTURER'S RECOMMENDED TOWING CAPACITY.

WARNING: ALL NON-TRAILER LOADS APPLIED TO THIS PRODUCT MUST BE SUPPORTED BY 18050 STABILIZING STRAPS.

** FAILURE TO PROPERLY SUPPORT NON-TRAILER LOADS WILL VOID PRODUCT WARRANTY**

HAVING INSTALLATION QUESTIONS? CALL TECHNICAL SUPPORT AT 1-800-798-0813

Parts List			
ITEM	QTY	PART NUMBER	DESCRIPTION
1	16	7/16 WASHER	WASHER
2	2	7/16-14 x 1 1/4	HEX BOLT
3	2	7/16-14	HEX FLANGE NUT
4	2	1/2-13 x 1 1/2	CARRIAGE BOLT
5	2	HFN 1213	HEX FLANGE NUT
6	2	CM-SP6	.250 x 1.00 x 3.00" SQUARE HOLE SPACER
7	2	1_2 FISHWIRE	1/2" FISHWIRE

TOOLS REQUIRED

RATCHET

8mm & 10mm SOCKETS

11/16" & 1/2" SOCKETS

18mm OPEN END/BOX WRENCH

5/8" OPEN END/BOX WRENCH

SMALL DISK GRINDER

TORQUE WRENCH

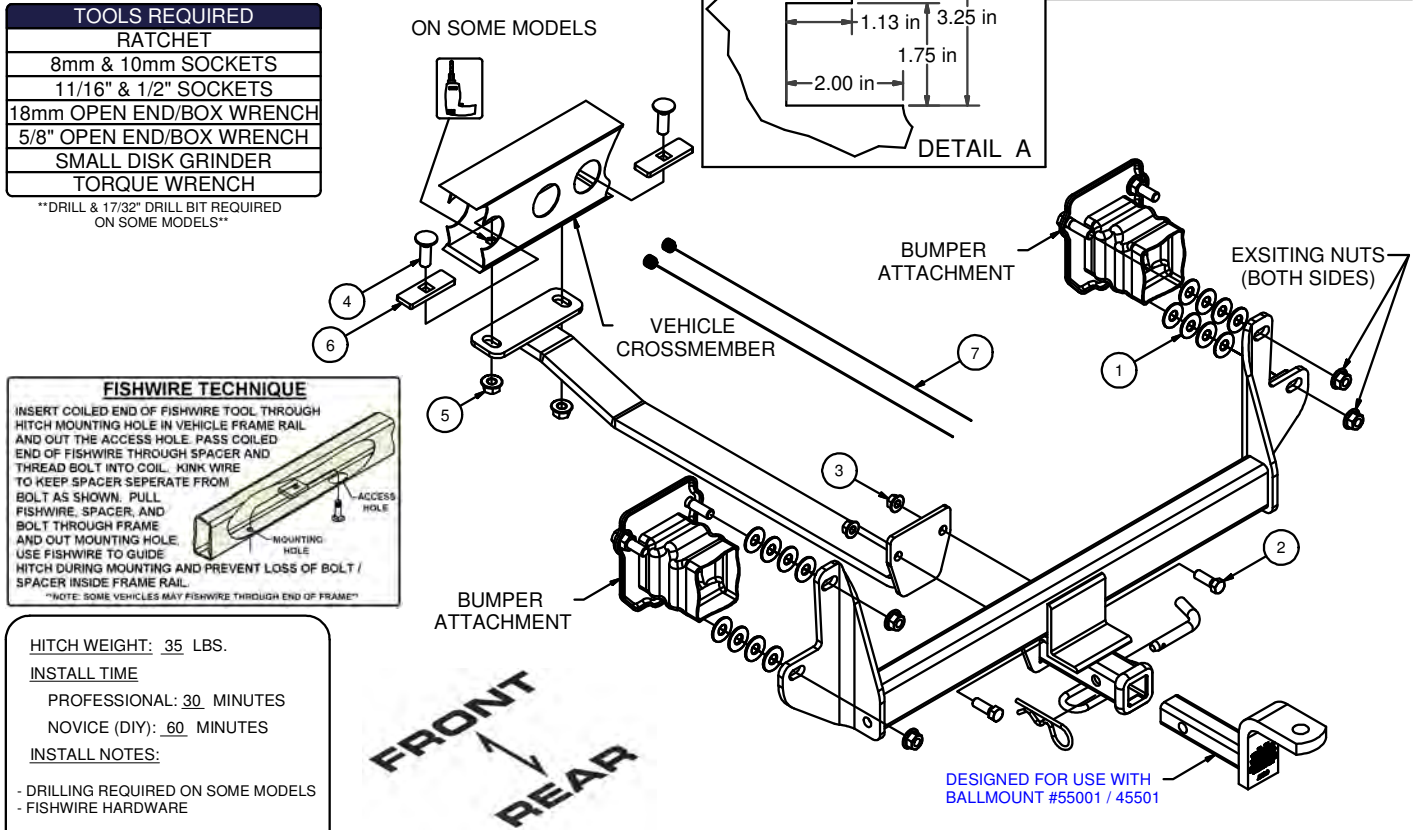
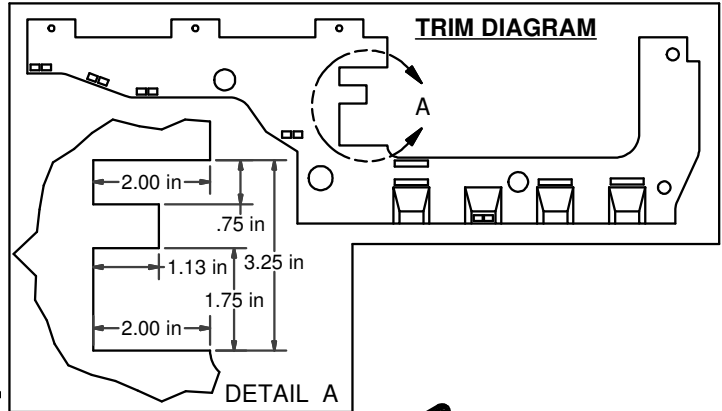
**DRILL & 17/32" DRILL BIT REQUIRED
ON SOME MODELS**

FISHWIRE TECHNIQUE

INSERT COILED END OF FISHWIRE TOOL THROUGH HITCH MOUNTING HOLE IN VEHICLE FRAME RAIL AND OUT THE ACCESS HOLE. PASS COILED END OF FISHWIRE THROUGH SPACER AND THREAD BOLT INTO COIL. KINK WIRE TO KEEP SPACER SEPARATE FROM BOLT AS SHOWN. PULL FISHWIRE, SPACER, AND BOLT THROUGH FRAME AND OUT MOUNTING HOLE. USE FISHWIRE TO GUIDE HITCH DURING MOUNTING AND PREVENT LOSS OF BOLT / SPACER INSIDE FRAME RAIL.

NOTE: SOME VEHICLES MAY FISHWIRE THROUGH END OF FRAME

HITCH WEIGHT: 35 LBS.

INSTALL TIME

PROFESSIONAL: 30 MINUTES

NOVICE (DIY): 60 MINUTES

INSTALL NOTES:

- DRILLING REQUIRED ON SOME MODELS
- FISHWIRE HARDWARE

INSTALLATION STEPS

1. Remove (14) fasteners which secure (2) underbody panels. These will be re-installed in STEP 9.
2. Remove (2) 12mm nuts from each bumper attachment, as shown above. These will be re-used in STEP 4.
3. Place (4) 7/16" washers on each stud where a nut was removed in STEP 2.
4. Lift the hitch into position over studs and secure with existing 12mm nuts.
5. Fishwire 1/2" carriage bolts and SP-6 spacers into vehicle crossmember, as shown. (See FISHWIRE TECHNIQUE above) Note: If holes are not present, use mounting strap as a template to mark & drill 17/32" holes.
6. Raise mounting strap into position and attach to vehicle crossmember with 1/2" flange nuts.
7. Attach mounting strap to the hitch using 7/16" fasteners, as shown above.
8. Torque all 7/16" hardware to 70 ft-lbs, 12mm hardware to 82 ft-lbs, and 1/2" hardware to 110 ft-lbs.
9. Trim (1) underbody panel. (See TRIM DIAGRAM above) Re-install both underbody panels.

PERIODICALLY CHECK THIS RECEIVER HITCH TO ENSURE THAT ALL FASTENERS ARE TIGHT AND THAT ALL STRUCTURAL COMPONENTS ARE SOUND.

Curt Manufacturing Inc., warrants this product to be free of defects in material and/or workmanship at the time of retail purchase by the original purchaser. If the product is found to be defective, Curt Manufacturing Inc., may repair or replace the product, at their option, when the product is returned, prepaid, with proof of purchase. Alteration to, misuse of, or improper installation of this product voids the warranty. Curt Manufacturing Inc.'s liability is limited to repair or replacement of products found to be defective, and specifically excludes liability for incidental or consequential loss or damage.