

**11041****94-04 FORD MUSTANG V6 (EXCEPT GT)**

10/5/2012

GROSS LOAD CAPACITY WHEN USED AS A WEIGHT CARRYING HITCH: 2,000 LBS. TRAILER WEIGHT &amp; 200 LBS. TONGUE WEIGHT.

**\*\*\*DO NOT EXCEED VEHICLE MANUFACTURER'S RECOMMENDED TOWING CAPACITY.\*\*\*****WARNING: ALL NON-TRAILER LOADS APPLIED TO THIS PRODUCT MUST BE SUPPORTED BY AUXILIARY STABILIZING STRAPS.****\*\* FAILURE TO PROPERLY SUPPORT NON-TRAILER LOADS WILL VOID PRODUCT WARRANTY\*\***

HAVING INSTALLATION QUESTIONS? CALL TECHNICAL SUPPORT AT 1-800-798-0813

Parts List			
ITEM	QTY	PART NUMBER	DESCRIPTION
1	2	3/8"	CONICAL TOOTHED WASHER
2	2	7/16-14	HEX FLANGE NUT
3	2	7/16-14 x 1 1/2	CARRIAGE BOLT
4	1	CM-438-FW	7/16" FISHWIRE TOOL
5	2	CM-SP32	.188 x 1.50 x 2.00" ROUND HOLE SPACER
6	2	CM-SP7	.250 x 1.00 x 2.00" SQUARE HOLE SPACER
7	2	M10 - 1.5 x 45mm	HEX BOLT

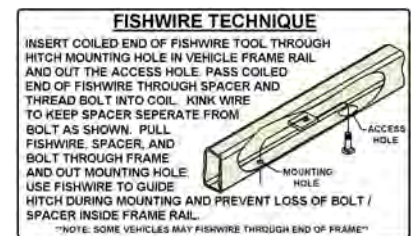
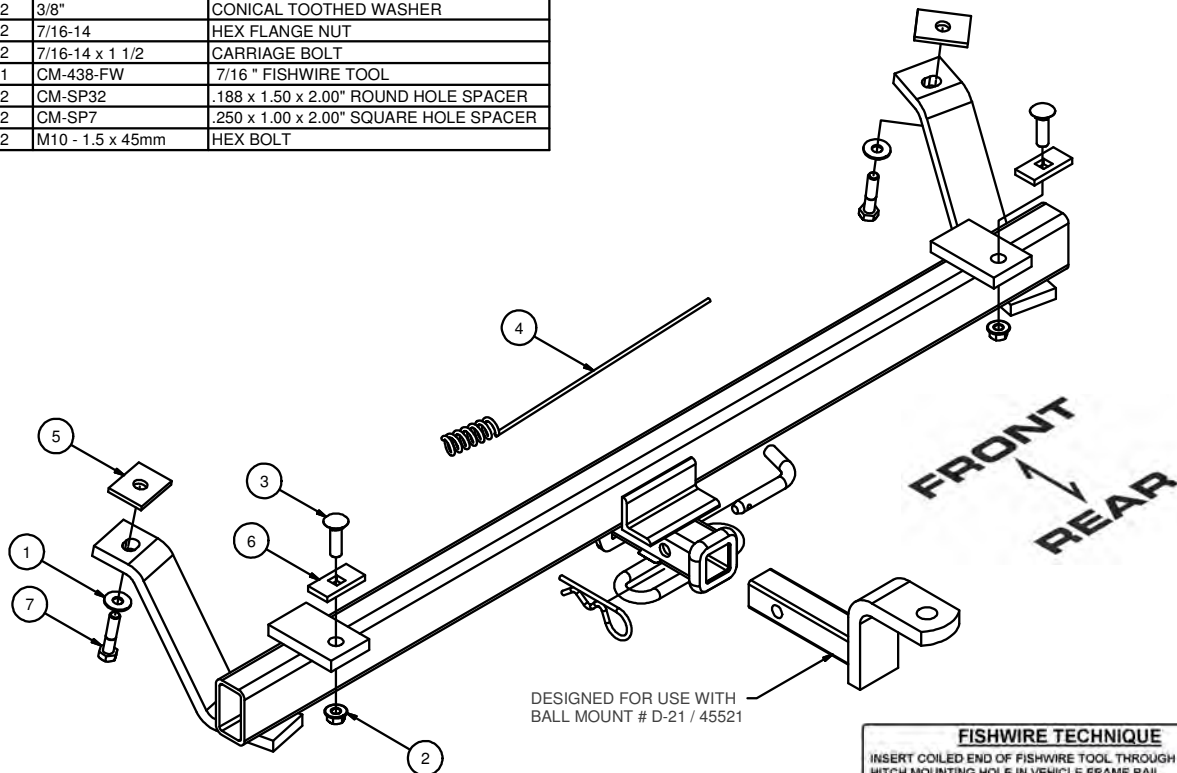

HITCH WEIGHT: 33 LBS.

INSTALL TIME

PROFESSIONAL: 30 MINUTES

NOVICE (DIY): 60 MINUTES

INSTALL NOTES:

DRILLING REQUIRED

**INSTALLATION STEPS**

- 1) Remove bumper bracket bolts from bottom of each frame rail - **FASTNERS WILL NOT BE REUSED** - Return to vehicle owner.
- 2) Raise hitch into position and install M10 bolt assemblies through hitch into existing weldnuts. **HAND TIGHTEN ONLY**. Discard M10 shipping nuts.
- 3) Using the tabs on the hitch as guides, drill (two) 7/16" holes in the bottom of the bumper.  
**Note: Bumper material is very tough and difficult to drill. Use 7/16" carbide drill bit.**
- 4) Drill a 1/4" hole and a 1" access hole in bottom of bumper inboard of each tab on hitch. The 1 x 2 block will fit through the 1" hole alone.  
**Note: On some models there is a rectangular hole that can be used for fishwiring and the 1" access hole will not have to be drilled.**
- 5) Fishwire through each access hole a 7/16" carriage bolt and block. Attach a flat washer, lock washer, and nut.
- 6) Check to see if receiver tube is level. Variations in bumper position may make it necessary to add a spacer (provided) between hitch side arm and frame rail, **TIGHTEN BOLTS**.
- 7) Torque M10 fasteners to 45 LB.-FT. and 7/16" fasteners to 70 LB.-FT.

**PERIODICALLY CHECK THIS RECEIVER HITCH TO ENSURE THAT ALL FASTENERS ARE TIGHT AND THAT ALL STRUCTURAL COMPONENTS ARE SOUND.**

Curt Manufacturing Inc., warrants this product to be free of defects in material and/or workmanship at the time of retail purchase by the original purchaser. If the product is found to be defective, Curt Manufacturing Inc., may repair or replace the product, at their option, when the product is returned, prepaid, with proof of purchase. Alteration to, misuse of, or improper installation of this product voids the warranty. Curt Manufacturing Inc.'s liability is limited to repair or replacement of products found to be defective, and specifically excludes liability for incidental or consequential loss or damage.