

11050/ 247050 TOYOTA YARIS 2 DOOR & HATCHBACK (EXCLUDING SE VERSION)

8/15/2013

VISIT WWW.HITCHINFO.COM FOR CURRENT APPLICATION COVERAGE,
INSTALLATION SUPPORT AND BENEFICIAL TOWING INFORMATION

GROSS LOAD CAPACITY WHEN USED AS A WEIGHT CARRYING HITCH: 2,000 LBS. TRAILER WEIGHT & 200 LBS. TONGUE WEIGHT.
DO NOT EXCEED VEHICLE MANUFACTURER'S RECOMMENDED TOWING CAPACITY.

Parts List			
ITEM	QTY	PART NUMBER	DESCRIPTION
1	2	5_8 - 11 x 2 HEX	HEX BOLT
2	2	5_8 - 11 HEX-NUT	5/8" 11 UNC HEX NUT
3	2	5_8 LOCK WASHER	5/8" HELICAL LOCK WASHER
4	4	3/8-16 x 1 1/2	HEX BOLT
5	4	3/8"	WASHER
6	4	3/8-16	HEX FLANGE NUT

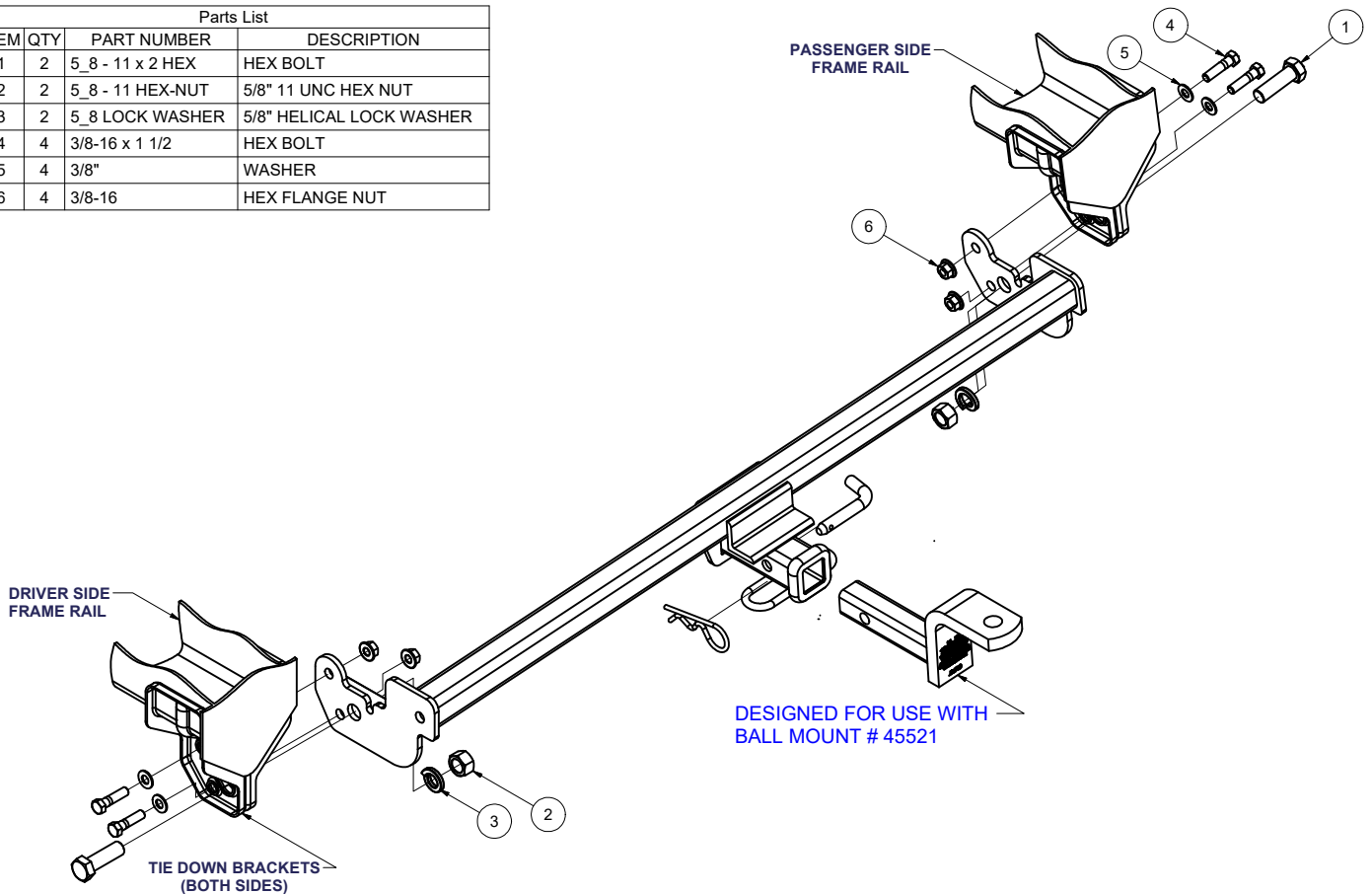

HITCH WEIGHT: 23 LBS.

INSTALL TIME: 35 MINUTES

INSTALL NOTES:

- UNFASTEN LOWER FASCIA
- NO DRILLING REQUIRED

NOTE:
HITCH ATTACHES TO THE TIE-DOWN BRACKETS ON BOTH SIDES

INSTALLATION STEPS

- 1) Bend middle tab of trunk pan down or cut off and discard.
- 2) Bumper beam edge may need to be trimmed.
- 3) Remove (2) plastic bumper fascia tab fasteners.
- 4) Raise hitch into position and install supplied fasteners as shown.
- 5) Torque all 3/8" fasteners to 45 lb-ft and all 5/8" fasteners to 210 lb-ft.
- 6) Re-install bumper fascia tabs to original position.

PERIODICALLY CHECK THIS RECEIVER HITCH TO ENSURE THAT ALL FASTENERS ARE TIGHT AND THAT ALL STRUCTURAL COMPONENTS ARE SOUND.

Curt Manufacturing Inc., warrants this product to be free of defects in material and/or workmanship at the time of retail purchase by the original purchaser. If the product is found to be defective, Curt Manufacturing Inc., may repair or replace the product, at their option, when the product is returned, prepaid, with proof of purchase. Alteration to, misuse of, or improper installation of this product voids the warranty. Curt Manufacturing Inc.'s liability is limited to repair or replacement of products found to be defective, and specifically excludes liability for incidental or consequential loss or damage.

8/15/2013