

**11099 / 24756 / 247099****VOLKSWAGEN RABBIT**

4/22/2008

**GROSS LOAD CAPACITY WHEN USED AS A WEIGHT CARRYING HITCH: 1,000 LBS. TRAILER WEIGHT & 100 LBS. TONGUE WEIGHT.**  
 \*\*\*DO NOT EXCEED VEHICLE MANUFACTURER'S RECOMMENDED TOWING CAPACITY.\*\*\*

Parts List			
ITEM	QTY	PART NUMBER	DESCRIPTION
1	1	1/2"	FISHWIRE TOOL
2	2	HFN 1213	HEX FLANGE NUT
3	4	M8 - 1.25 x 30 HEX BOLT	HEX HEAD BOLT
4	2	1/2-13 x 1 3/4	CARRIAGE BOLT
5	2	CM-SP10	.250 x 1.00 x 2.50" SQUARE HOLE SPACER

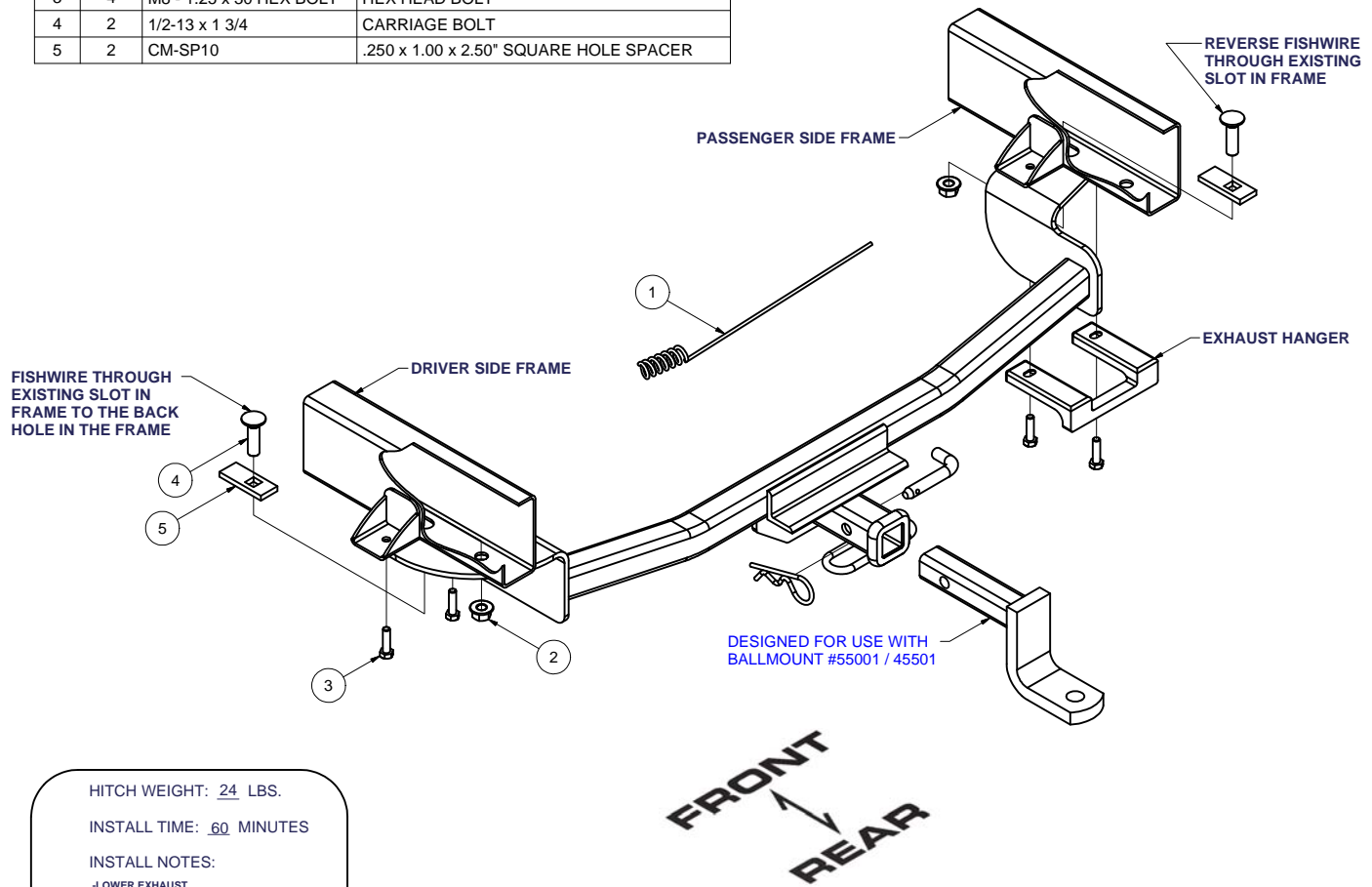

HITCH WEIGHT: 24 LBS.  
 INSTALL TIME: 60 MINUTES  
 INSTALL NOTES:  
 -LOWER EXHAUST  
 -TRIM HEAT SHIELD  
 -FISHWIRING REQUIRED  
 -FASCIA TRIMMING REQUIRED  
 -NO DRILL

**INSTALLATION STEPS**

- 1) Lower exhaust on driver side, passenger side(remove exhaust hanger), and center of vehicle.
- 2) Remove heat shield, trim off wings and front lip. Re-attach with four existing fasteners.
- 3) Fishwire 1/2" carriage bolts and SP-10 spacers to proper locations on driver and passenger side frames.
- 4) Lift hitch into position to mark where receiver tube hits bumper fascia. Trim bumper fascia to fit.
- 5) Lift hitch and exhaust back into position at the same time. (Note: Once hitch is mounted the exhaust can not be lifted back into place). Attach with 1/2" flange nuts and to existing weldnuts with M8 bolts (4).
- 6) Tighten all 1/2" hardware to 75 ft-lbs and all M8 bolts to 17 ft-lbs.
- 7) Raise exhaust back into position.

PERIODICALLY CHECK THIS RECEIVER HITCH TO ENSURE THAT ALL FASTENERS ARE TIGHT AND THAT ALL STRUCTURAL COMPONENTS ARE SOUND.

Curt Manufacturing Inc., warrants this product to be free of defects in material and/or workmanship at the time of retail purchase by the original purchaser. If the product is found to be defective, Curt Manufacturing Inc., may repair or replace the product, at their option, when the product is returned, prepaid, with proof of purchase. Alteration to, misuse of, or improper installation of this product voids the warranty. Curt Manufacturing Inc.'s liability is limited to repair or replacement of products found to be defective, and specifically excludes liability for incidental or consequential loss or damage.