

11122 Installation Instructions

! A pair of safety glasses should be worn at all times while installing this product

YEARS: 2010-CURRENT	MAKE: CHEVROLET	MODEL: CAMARO	STYLE: COUPE
-------------------------------	---------------------------	-------------------------	------------------------

WARNING: NEVER EXCEED YOUR VEHICLE MANUFACTURER'S RECOMMENDED TOWING CAPACITY

WEIGHT CARRYING:
2,000 LBS TRAILER WEIGHT
200 LBS TONGUE WEIGHT

WARNING:
NOT TO BE USED WITH WEIGHT DISTRIBUTION SYSTEMS
ALL NON-TRAILER LOADS APPLIED TO THIS PRODUCT MUST BE SUPPORTED BY AUXILIARY STABILIZING STRAPS
FAILURE TO PROPERLY SUPPORT NON-TRAILER LOADS WILL VOID THE WARRANTY

INSTALLATION TIME: 60 MIN.
THE INSTALL TIME LISTED IS FOR PROFESSIONAL INSTALLERS. IF YOU ARE HESITANT TO UNDERTAKE THIS TASK ON YOUR OWN, CONTACT AN AUTHORIZED CURT INSTALLER FOR ADDITIONAL ASSISTANCE.

INSTALLATION TIPS:
1.) BEFORE YOU BEGIN INSTALLATION, READ ALL INSTRUCTIONS THOROUGHLY.
2.) TO EASE INSTALLATION, 2 PEOPLE MAY BE REQUIRED.
3.) USING PROPER TOOLS WILL GREATLY IMPROVE THE QUALITY OF THE INSTALL AND REDUCE THE TIME REQUIRED.
4.) NEED HELP OR HAVE SOME QUESTIONS? CALL TECHNICAL SUPPORT AT 800.798.0813



INSTALLATION REQUIRES:

DIE GRINDER	POWER DRILL	DRILL BIT 17/32"
RATCHET	SOCKET 3/4"	SOCKET 7mm
TORQUE WRENCH	SPRAY LUBRICANT	PRY BAR
MARKER		

LEVEL OF DIFFICULTY: HARD

EASY	MODERATE	HARD
	MUST FISHWIRE (4) 1/2" FASTENERS INTO FRAME RAILS	
	MUST REMOVE (4) REARMOST EXHAUST HANGERS	
	TO EASE INSTALLATION REMOVE (6) BOLTS FROM FASCIA SUPPORT	
	MUST DRILL (2) HOLES INTO BUMPER BEAM	

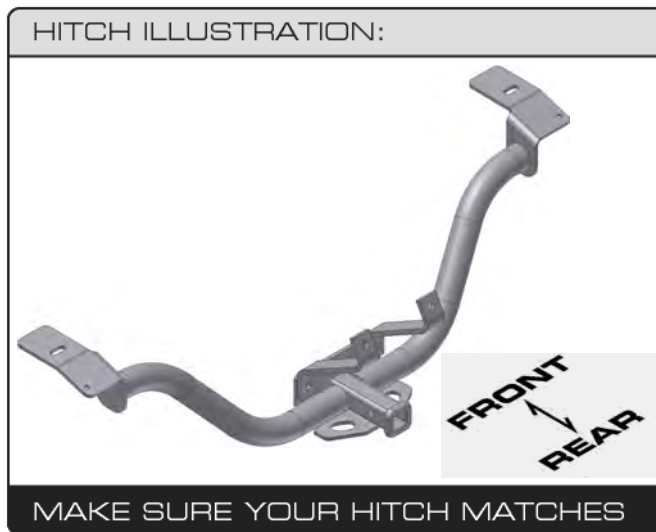

PERIODICALLY CHECK THIS RECEIVER HITCH TO ENSURE ALL FASTENERS ARE TIGHT AND ALL STRUCTURAL COMPONENTS ARE SOUND
CURT Manufacturing Inc., warrants this product to be free of defects in material and/or workmanship at the time of retail purchase by the original purchaser. If the product is found to be defective, CURT Manufacturing Inc. may repair or replace the product, at their option, when the product is returned, prepaid, with proof of purchase. Alteration to, misuse of, or improper installation of this product voids the warranty. CURT Manufacturing Inc.'s liability is limited to repair or replacement of products found to be defective, and specifically excludes liability for incidental or consequential loss or damage.

INSTALLATION WALKTHROUGH:

1. Remove (4) rearmost rubber isolators from exhaust. Outside rubber isolator must be removed from both exhaust and hanger while the inside rubber isolator is left attached to hanger on both driver and passenger sides.



DRIVER SIDE



PASSENGER SIDE



2. Remove (2) rubber isolators from center of vehicle.



**RUBBER ISOLATOR
REMOVAL DIAGRAM**

This technique can be used if an Exhaust Hanger Removal Pliers is not available.

Using a 5/8" open end wrench, slide the wrench up to the rubber isolator, cradling the hanger rod as shown. Next place the flat edge of a pry bar between the wrench and the hanger stop or hanger rod. Then simply rotate the pry bar toward the wrench to remove the rubber isolator.

Note: Using a spray lubricant or soapy water on the hanger rod and the rubber isolator helps removal.

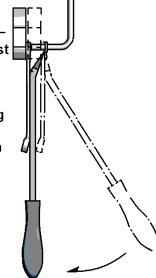

3. For ease of installation remove (6) bolts that attach fascia to underbody support using a 7mm socket.



DRIVER SIDE



PASSENGER SIDE



4. Open trunk, fold carpet over and remove rubber plug on both driver and passenger sides to expose TRUNK ACCESS HOLES.



INSTALLATION WALKTHROUGH:

- Using 20" fishwires, pull a CM-SP19 spacer and 1/2" carriage bolt through the TRUNK ACCESS HOLE on both sides. (See FISHWIRE TECHNIQUE diagram) Leave fishwires attached to bolts to prevent the hardware from being pushed back up into the frame.

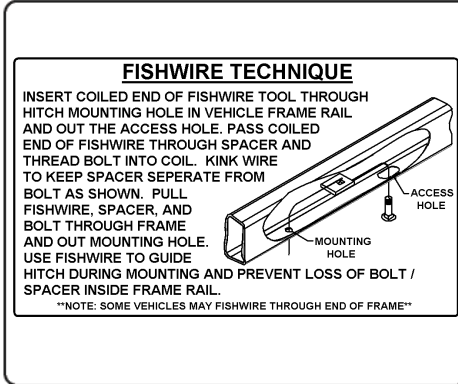
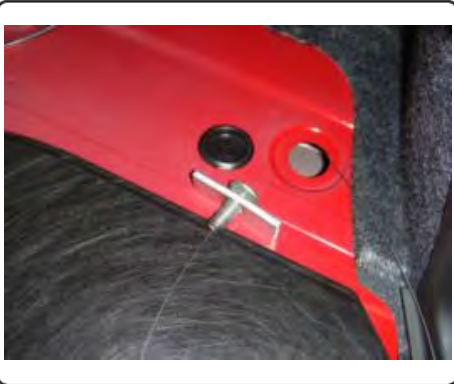

- Raise hitch into position, feeding the fishwires through the hitch mounting holes.
- Remove fishwires from Step 5 and loosely install 1/2" flange nuts.

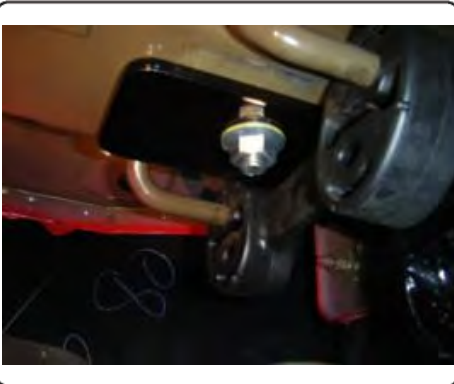

- Install mounting straps using 1/2" carriage bolts and 1/2" flange nuts, as shown. Adjust hitch so the MOUNTING STRAPS are flush with the BUMPER BEAM.
- Tighten hardware installed in Step 8 using a 3/4" socket.

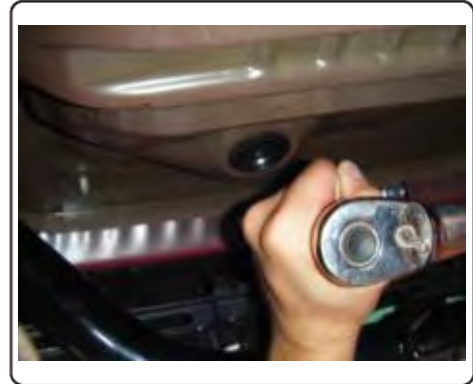
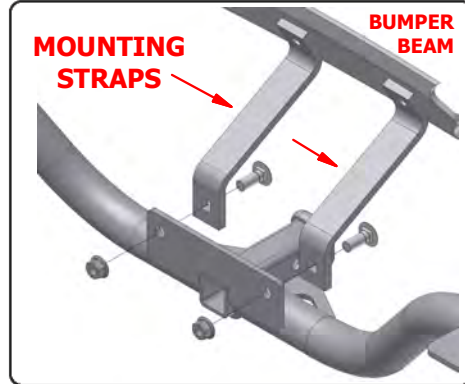

- Using the mounting straps as a template, mark the hole locations on the BUMPER BEAM.
 - Take straps out of position and drill one hole for each strap. Drill holes using 17/32" drill bit.
- Note:** Use a die grinder to enlarge drilled holes vertically if necessary.

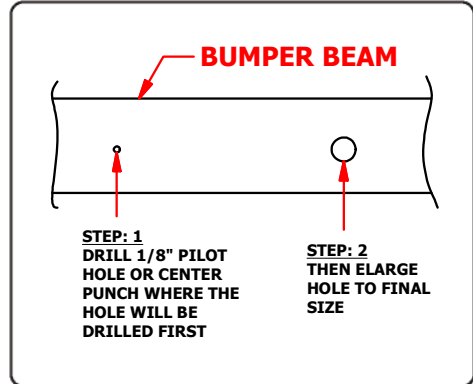

INSTALLATION WALKTHROUGH:

12. Using 30" fishwires, pull a CM-SP6 spacer and 1/2" carriage bolt through ends of BUMPER BEAM into drilled holes, as shown. (See FISHWIRE TECHNIQUE diagram) Leave fishwires attached to prevent losing hardware in frame. Repeat for other drilled hole.



13. Re-install mounting straps into position, pulling fishwires through mounting strap holes. Loosely install the 1/2" carriage bolts and 1/2" flange nuts that attach mounting straps to hitch.



14. Remove fishwires from bolts installed in Step 12 and attach 1/2" flange nuts.



15. Torque all 1/2" hardware to 110 lb-ft using a 3/4" socket.

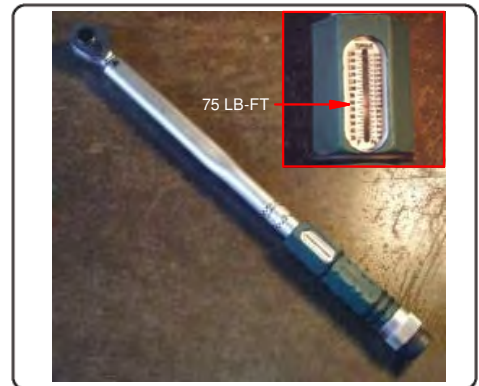

INSTALLATION WALKTHROUGH:

16. Raise exhaust back into position and re-install (4) rubber isolators removed in Step 1.



**BEFORE ATTACHING RUBBER ISOLATORS
BE SURE TO PLACE EXHAUST TIPS THROUGH THE HOLES IN THE LOWER BUMPER VALANCE**



17. Reinstall (6) bolts removed in Step 3 using a 7mm socket.



DRIVER SIDE

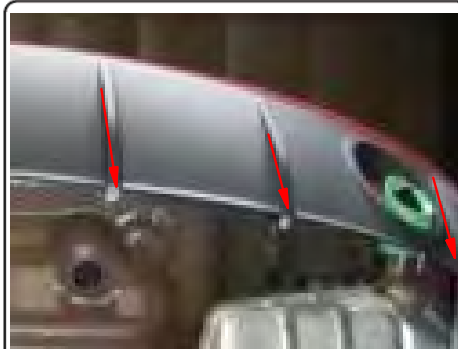

PASSENGER SIDE

Hitch shown correctly installed on vehicle.



BEFORE TOWING:

BE SURE TO TEST FIT BALLMOUNT OR ACCESSORY IN HITCH TO MAKE SURE THERE IS ENOUGH CLEARANCE BEFORE ATTACHING TRAILER.



11122

CHEVROLET CAMARO

11/12/2012

WILL NOT FIT WITH GROUND EFFECTS

GROSS LOAD CAPACITY WHEN USED AS A WEIGHT CARRYING HITCH: 2,000 LBS. TRAILER WEIGHT & 200 LBS. TONGUE WEIGHT.

DO NOT EXCEED VEHICLE MANUFACTURER'S RECOMMENDED TOWING CAPACITY.

WARNING: ALL NON-TRAILER LOADS APPLIED TO THIS PRODUCT MUST BE SUPPORTED BY AUXILIARY STABILIZING STRAPS.

** FAILURE TO PROPERLY SUPPORT NON-TRAILER LOADS WILL VOID PRODUCT WARRANTY**

HAVING INSTALLATION QUESTIONS? CALL TECHNICAL SUPPORT AT 1-800-798-0813

		Parts List	
ITEM	QTY	PART NUMBER	DESCRIPTION
1	6	1/2-13 x 1 1/4	CARRIAGE BOLT
2	6	HFN 1213	HEX FLANGE NUT
3	2	CM-SP6	.250 x 1.00 x 3.00" SQUARE HOLE SPACER
4	2	CM-SP19	.250 x 1.25 x 3.00" SQUARE HOLE SPACER
5	2	1_2 x 30 FISHWIRE	1/2" x 30" FISHWIRE
6	2	1_2 FISHWIRE	1/2" FISHWIRE

FISHWIRE TECHNIQUE

INSERT COILED END OF FISHWIRE TOOL THROUGH HITCH MOUNTING HOLE IN VEHICLE FRAME RAIL AND OUT THE ACCESS HOLE. PASS COILED END OF FISHWIRE THROUGH SPACER AND THREAD BOLT INTO COIL. KINK WIRE TO KEEP SPACER SEPERATE FROM BOLT AS SHOWN. PULL FISHWIRE, SPACER, AND BOLT THROUGH FRAME AND OUT MOUNTING HOLE. USE FISHWIRE TO GUIDE HITCH DURING MOUNTING AND PREVENT LOSS OF BOLT / SPACER INSIDE FRAME RAIL.

NOTE: SOME VEHICLES MAY FISHWIRE THROUGH END OF FRAME

TOOLS REQUIRED

SOCKET WRENCH
3/4 in, 7mm SOCKET
RATCHET EXTENSION
TORQUE WRENCH
DRILL
17/32 in DRILL BIT
DIE GRINDER

RUBBER ISOLATOR REMOVAL DIAGRAM

This technique can be used if and Exhaust Hanger Removal Pliers is not available.

Using a 5/8" open end wrench, slide the wrench up to the rubber isolator, cradling the hanger rod as shown. Next place the flat edge of a pry bar between the wrench and the hanger stop or hanger rod. Then simply rotate the pry bar toward the wrench to remove the rubber isolator.

Note: Using a spray lubricant or soapy water on the hanger rod and the rubber isolator helps removal.

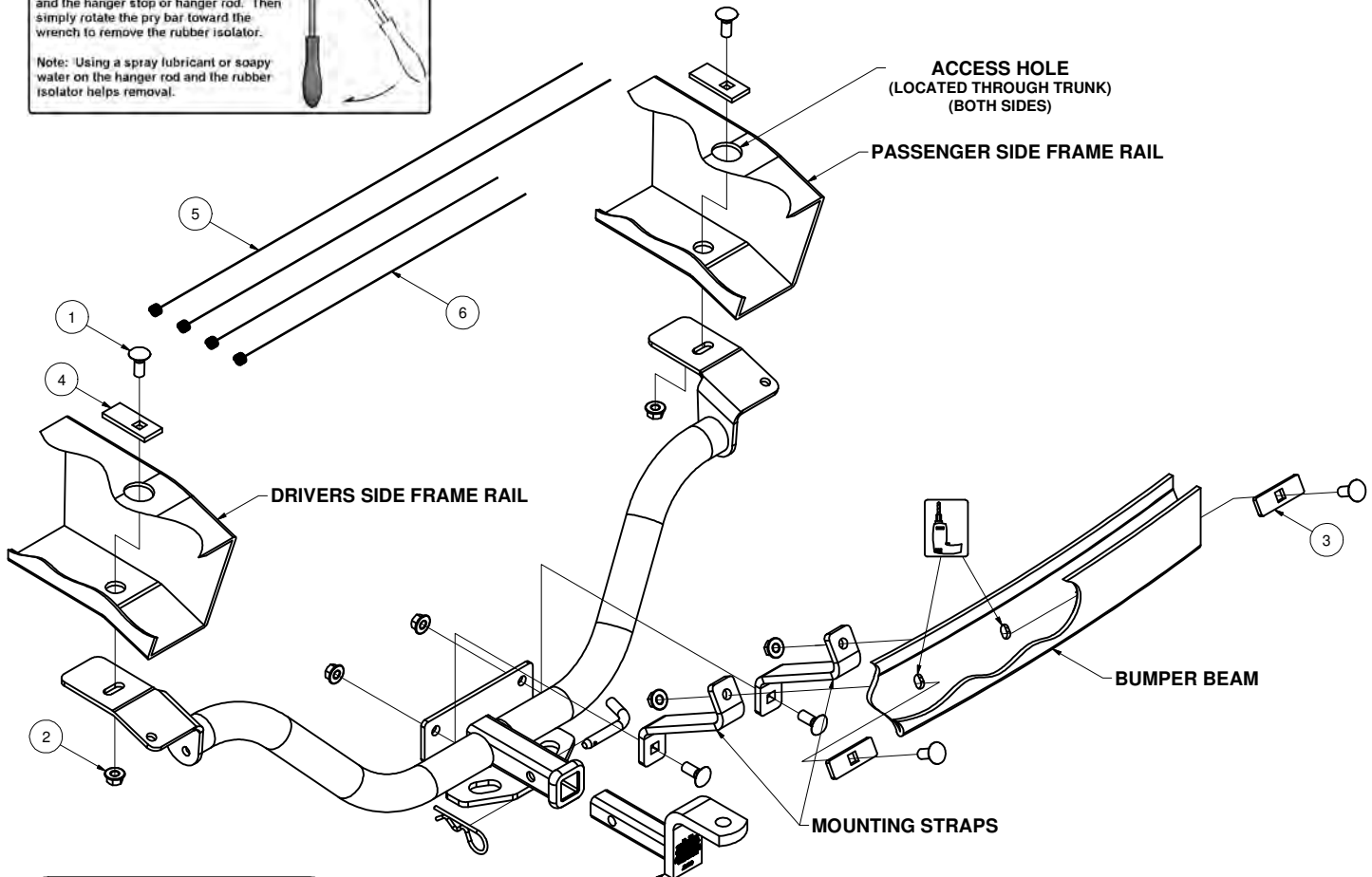

HITCH WEIGHT: TBD LBS.
 INSTALL TIME
 PROFESSIONAL: 60 MINUTES
 NOVICE (DIY): 125 MINUTES
 INSTALL NOTES:
 -DRILLING REQUIRED

DESIGNED FOR USE WITH BALLMOUNT #55001 / 45501



PERIODICALLY CHECK THIS RECEIVER HITCH TO ENSURE THAT ALL FASTENERS ARE TIGHT AND THAT ALL STRUCTURAL COMPONENTS ARE SOUND.

Curt Manufacturing Inc., warrants this product to be free of defects in material and/or workmanship at the time of retail purchase by the original purchaser. If the product is found to be defective, Curt Manufacturing Inc., may repair or replace the product, at their option, when the product is returned, prepaid, with proof of purchase. Alteration to, misuse of, or improper installation of this product voids the warranty. Curt Manufacturing Inc.'s liability is limited to repair or replacement of products found to be defective, and specifically excludes liability for incidental or consequential loss or damage.

HAVING INSTALLATION QUESTIONS? CALL TECHNICAL SUPPORT AT 1-800-798-0813



(PHOTO 1)



(PHOTO 2)

INSTALLATION STEPS

1. Remove (4) rearmost rubber isolators from exhaust. Outside rubber isolator must be removed from both exhaust and hanger while the inside rubber isolator is left attached to hanger on both driver and passenger sides. (See PHOTO 1 above) (See RUBBER ISOLATOR REMOVAL DIAGRAM)
2. Remove (2) rubber isolators from center of vehicle.
3. For ease of installation remove (6) bolts that attach fascia to underbody support.
4. Open trunk, fold carpet over and remove rubber plug on both driver and passenger sides to expose TRUNK ACCESS HOLES. (See PHOTO 2 above)
5. Using 20" fishwires, pull a CM-SP19 spacer and 1/2" carriage bolt through the TRUNK ACCESS HOLE on both sides. (See FISHWIRE TECHNIQUE diagram) Leave fishwires attached to bolts to prevent the hardware from being pushed back up into the frame.
6. Raise hitch into position, feeding the fishwires through the hitch mounting holes.
7. Remove fishwires from STEP 5 and loosely install 1/2" flange nuts.
8. Install mounting straps using 1/2" carriage bolts and 1/2" flange nuts, as shown. Adjust hitch so MOUNTING STRAPS are flush with the BUMPER BEAM.
9. Tighten hardware installed in STEP 8.
10. Using straps as a template mark the hole locations on the BUMPER BEAM.
11. Take straps out of position and drill one hole for each strap. Drill holes using 17/32" drill bit.
Note: Use a die grinder to enlarge drilled holes vertically if necessary.
12. Using 30" fishwires, pull a CM-SP6 spacer and 1/2" carriage bolt through ends of BUMPER BEAM, as shown. (See FISHWIRE TECHNIQUE diagram) Leave fishwire attached to bolt to prevent losing hardware in frame. Repeat for other drilled hole.
13. Put mounting straps back into position, feeding fishwires through mounting strap holes. Loosely install 1/2" carriage bolts and 1/2" flange nuts that attach mounting straps to hitch, as shown.
14. Remove fishwires from STEP 12 and install 1/2" flange nuts.
15. Torque all 1/2" hardware to 110 lb-ft.
16. Raise exhaust back into position.
17. Reinstall (6) bolts removed in STEP 3.

PERIODICALLY CHECK THIS RECEIVER HITCH TO ENSURE THAT ALL FASTENERS ARE TIGHT AND THAT ALL STRUCTURAL COMPONENTS ARE SOUND.