

**YEARS:** 2006-PRESENT

**MAKE:** SAAB

**MODEL:** 9-3X & 9-3 SPORTCOMBI

**STYLE:** WAGON

**WARNING: NEVER EXCEED YOUR VEHICLE MANUFACTURER'S RECOMMENDED TOWING CAPACITY**

**WEIGHT CARRYING:**  
**TRAILER WEIGHT:** 2,000 LBS.  
**TONGUE WEIGHT:** 200 LBS.

**WARNING:**  
 WE RECOMMEND THE USE OF 18050 STABILIZING STRAPS FOR ALL NON-TRAILER (WHEEL-LESS) LOADS. PLEASE SEE THE CURT CATALOG OR VISIT US ONLINE AT [WWW.CURTMFG.COM](http://WWW.CURTMFG.COM) FOR FURTHER INFORMATION.

**INSTALLATION TIME: 30 MIN.**

THE INSTALL TIME LISTED IS FOR PROFESSIONAL INSTALLERS. IF YOU ARE HESITANT TO UNDERTAKE THIS TASK ON YOUR OWN, CONTACT AN AUTHORIZED CURT INSTALLER FOR ADDITIONAL ASSISTANCE.

**INSTALLATION REQUIRES:**

<b>RATCHET</b>	<b>TORQUE WRENCH</b>	<b>6" SOCKET EXTENSION</b>
<b>11/16" 9/16" 17mm 10mm SOCKET</b>	<b>AVIATION SHEARS</b>	<b>SAFETY GLASSES</b>
<b>ROTARY TOOL (OPTIONAL)</b>	<b>MASKING TAPE</b>	

**INSTALLATION TIPS:**

- BEFORE YOU BEGIN INSTALLATION, READ ALL INSTRUCTIONS THOROUGHLY.
- TO EASE INSTALLATION, 2 PEOPLE MAY BE REQUIRED.
- USING PROPER TOOLS WILL GREATLY IMPROVE THE QUALITY OF THE INSTALL AND REDUCE THE TIME REQUIRED.
- NEED HELP OR HAVE SOME QUESTIONS? CALL TECHNICAL SUPPORT AT 800.798.0813

**LEVEL OF DIFFICULTY: EASY**

<i>EASY</i>	<i>MODERATE</i>	<i>CHALLENGING</i>
	- NO DRILLING REQUIRED	
	- FASCIA TRIMMING REQUIRED	

**VEHICLE PHOTO:**



**REPRESENTATIVE PHOTO**

**HITCH ILLUSTRATION:**

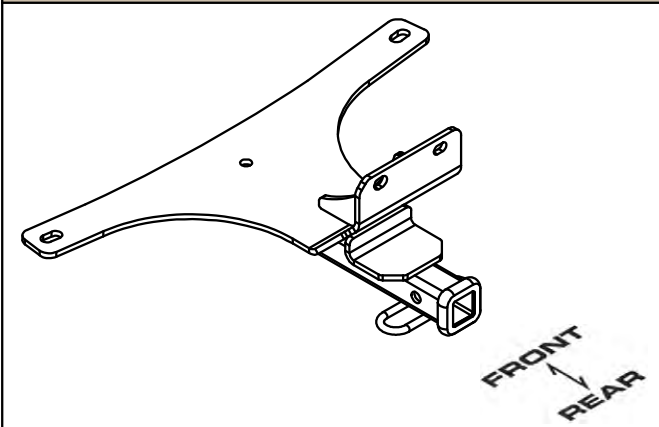

**MAKE SURE YOUR HITCH MATCHES**

**PERIODICALLY CHECK THIS RECEIVER HITCH TO ENSURE ALL FASTENERS ARE TIGHT AND ALL STRUCTURAL COMPONENTS ARE SOUND**

CURT Manufacturing LLC. warrants this product to be free of defects in material and/or workmanship at the time of retail purchase by the original purchaser. If the product is found to be defective, Curt Manufacturing LLC. may repair or replace the product at their option, when the product is returned, prepaid, with proof of purchase. Alteration to, misuse of, or improper installation of this product voids the warranty. Curt Manufacturing LLC.'s liability is limited to repair or replacement of products found to be defective, and specifically excludes liability for incidental or consequential loss or damage.

For more information log onto [www.curtmfg.com](http://www.curtmfg.com), & for helpful towing tips log onto [www.hitchinfo.com](http://www.hitchinfo.com)

## INSTALLATION WALKTHROUGH:

Parts List			
ITEM	QTY	PART NUMBER	DESCRIPTION
1	2	M10 - 1.5 x 25mm	HEX BOLT
2	2	7/16"	CONICAL TOOTHED WASHER
3	1	7/16-14	HEX FLANGE NUT
4	1	HFN3816	HEX FLANGE NUT
5	1	CM-SP7	.250 x 1.00 x 2.00" SQUARE HOLE SPACER
6	1	7/16-14 x 1 1/2	CARRIAGE BOLT
7	1	3/8-16 x 1 1/4 LG.	CARRIAGE BOLT
8	1	CM-SP18	.250 x 1.00 x 2.00" SQUARE HOLE SPACER

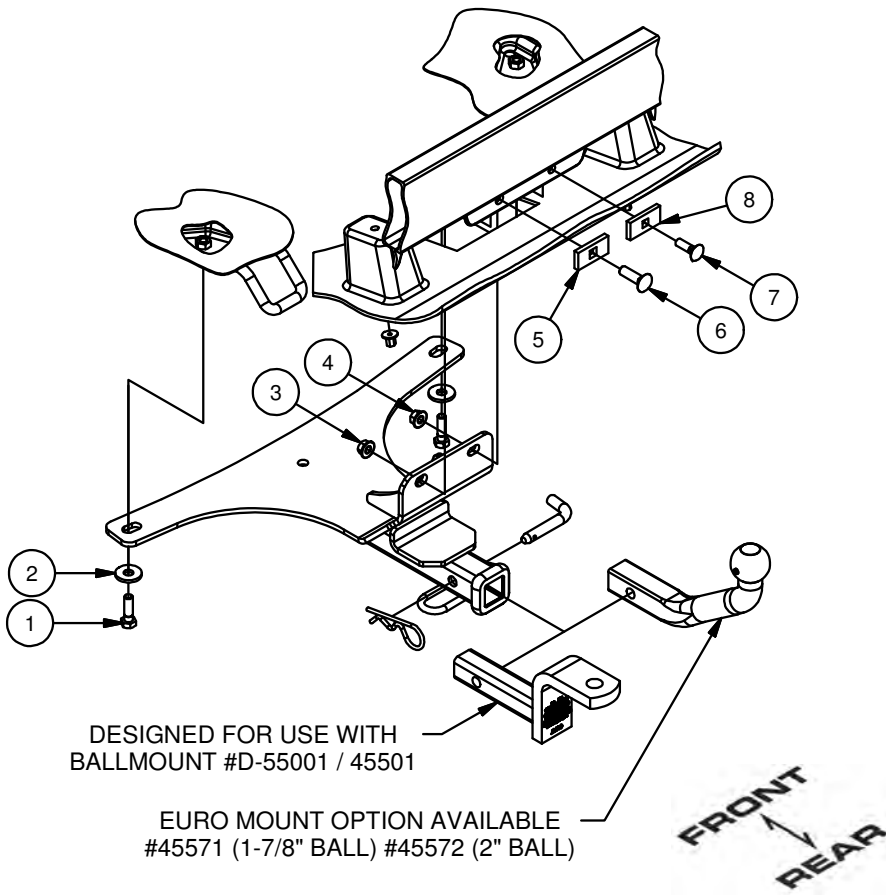

1. Remove (2) fascia nuts from the under body panel.



2. Mark and trim the under body panel. **Note:** Dimensions are approximate, confirm fit prior to trimming.

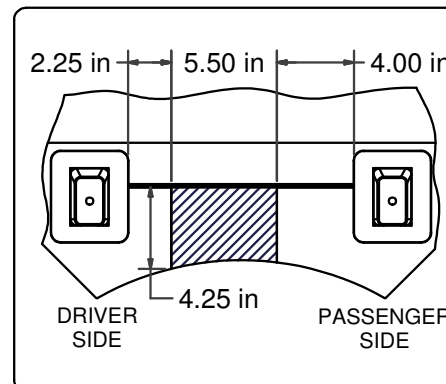

## INSTALLATION WALKTHROUGH:

3. Insert a 7/16-14 x 1 1/2 carriage bolt and SP7 spacer through the hole in the driver side of the bumper beam tab. Insert a 3/8-16 x 1 1/4" carriage bolt and SP18 spacer through the hole in the passenger side of the bumper beam tab.



4. Raise hitch into position and loosely secure the rear of the hitch to the fasteners installed in Step (3) with a 7/16-14 flange nut and a 3/8-16 flange nut. Secure the front of the hitch to the existing weldnuts with M10-1.5 x 25mm hex bolts and 7/16" conical toothed washers.

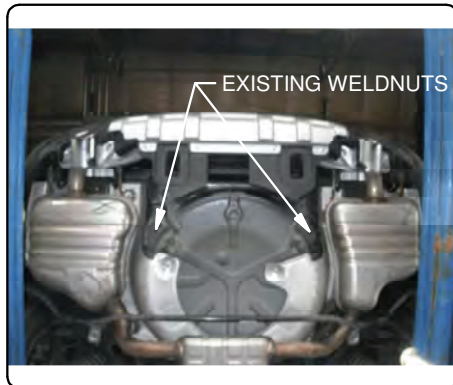
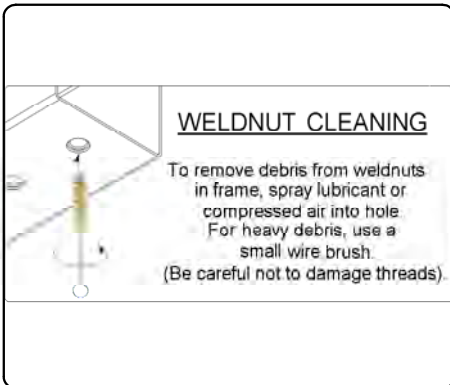

5. Torque all 3/8" fasteners to 45 ft-lbs. Torque all 7/16" fasteners to 70 ft-lbs. Torque all M10 fasteners to 45 ft-lbs. Reinstall the (2) fascia nuts removed in Step (1).



Install Complete.



**11140****SAAB 9-3 X & SPORTCOMBI**

11/26/2012

**GROSS LOAD CAPACITY WHEN USED AS A WEIGHT CARRYING HITCH: 2,000 LBS. TRAILER WEIGHT & 200 LBS. TONGUE WEIGHT.****\*\*\*DO NOT EXCEED VEHICLE MANUFACTURER'S RECOMMENDED TOWING CAPACITY.\*\*\*****WARNING: ALL NON-TRAILER LOADS APPLIED TO THIS PRODUCT MUST BE SUPPORTED BY 18050 STABILIZING STRAPS.****\*\* FAILURE TO PROPERLY SUPPORT NON-TRAILER LOADS WILL VOID PRODUCT WARRANTY\*\*****HAVING INSTALLATION QUESTIONS? CALL TECHNICAL SUPPORT AT 1-800-798-0813**

Parts List			
ITEM	QTY	PART NUMBER	DESCRIPTION
1	2	M10 - 1.5 x 25mm	HEX BOLT
2	2	7/16"	CONICAL TOOTHED WASHER
3	1	7/16-14	HEX FLANGE NUT
4	1	HFN3816	HEX FLANGE NUT
5	1	CM-SP7	.250 x 1.00 x 2.00" SQUARE HOLE SPACER
6	1	7/16-14 x 1 1/2	CARRIAGE BOLT
7	1	3/8-16 x 1 1/4 LG.	CARRIAGE BOLT
8	1	CM-SP18	.250 x 1.00 x 2.00" SQUARE HOLE SPACER

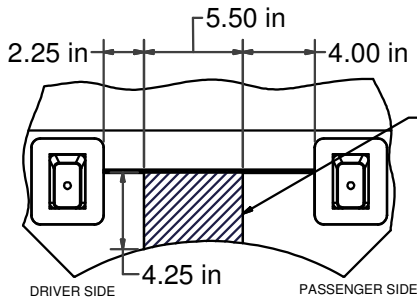
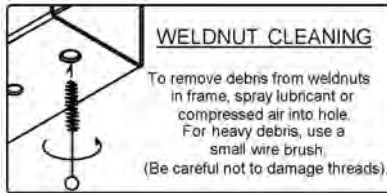

**NOTE: DIMENSIONS ARE APPROXIMATE, CONFIRM FIT BEFORE TRIMMING**

**UNDERBODY TRIM DIAGRAM****HITCH WEIGHT: 20 LBS.****INSTALL TIME**

PROFESSIONAL: 30 MINUTES

NOVICE (DIY): 60 MINUTES

**INSTALL NOTES:**

- NO DRILLING REQUIRED
- FASCIA TRIMMING REQUIRED

**TOOLS REQUIRED**

RATCHET
TORQUE WRENCH
6" EXTENSION
11/16" SOCKET
9/16" SOCKET
17mm SOCKET
10mm SOCKET
AVIATION SHEARS

DESIGNED FOR USE WITH BALLMOUNT #D-55001 / 45501

EURO MOUNT OPTION AVAILABLE #45571 (1-7/8" BALL) #45572 (2" BALL)

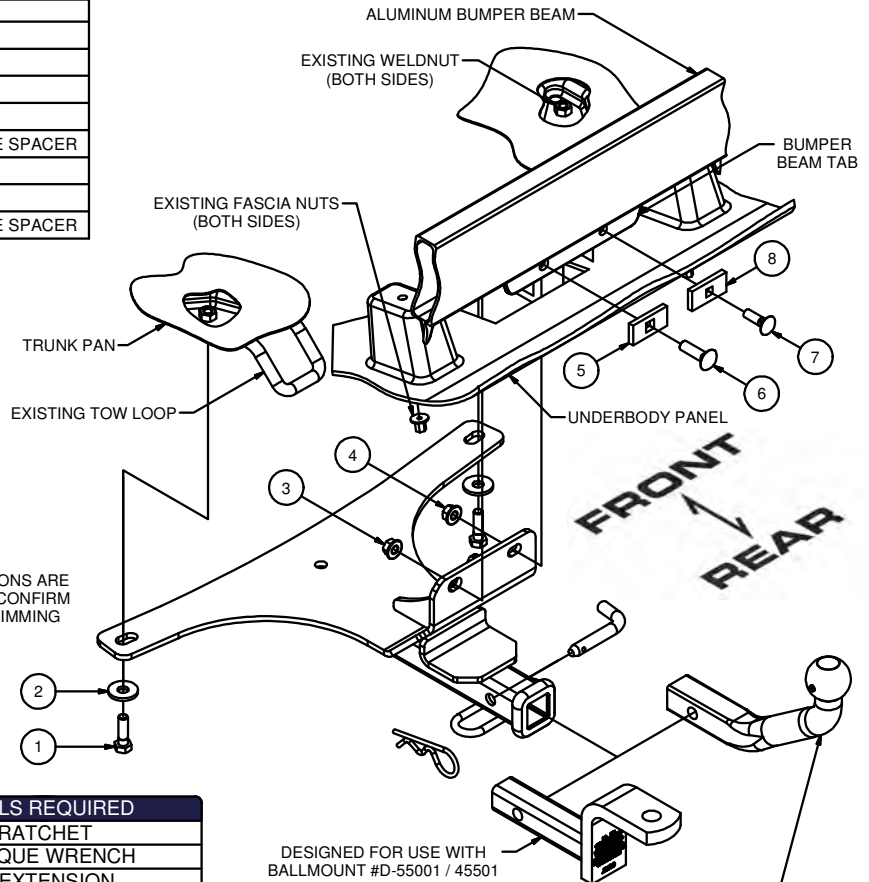
**INSTALLATION STEPS**

1. Remove (2) fascia nuts from the under body panel.
2. Mark and trim underbody panel. **Note:** Dimensions are approximate, confirm fit prior to trimming. (See Underbody Trim Diagram)
3. Insert a 7/16-14 x 1 1/2 carriage bolt and SP7 spacer through the hole in the driver side of the bumper beam tab. Insert a 3/8-16 x 1 1/4 carriage bolt and SP18 spacer through the hole in the passenger side of the bumper beam tab.
4. Raise hitch into position and loosely secure the rear of the hitch to the fasteners installed in Step (3) with a 7/16-14 flange nut and 3/8-16 flange nut.
5. Secure the front of the hitch to the existing weldnuts with M10-1.5 x 25mm hex bolts and 7/16" conical toothed washers. (See Weldnut Cleaning Diagram)
6. Torque all 3/8" fasteners to 45 ft-lbs.  
Torque all 7/16" fasteners to 70 ft-lbs.  
Torque all M10 fasteners to 45 ft-lbs.
7. Reinstall the (2) fascia nuts removed in Step (1).

**PERIODICALLY CHECK THIS RECEIVER HITCH TO ENSURE THAT ALL FASTENERS ARE TIGHT AND THAT ALL STRUCTURAL COMPONENTS ARE SOUND.**

Curt Manufacturing Inc., warrants this product to be free of defects in material and/or workmanship at the time of retail purchase by the original purchaser. If the product is found to be defective, Curt Manufacturing Inc., may repair or replace the product, at their option, when the product is returned, prepaid, with proof of purchase. Alteration to, misuse of, or improper installation of this product voids the warranty. Curt Manufacturing Inc.'s liability is limited to repair or replacement of products found to be defective, and specifically excludes liability for incidental or consequential loss or damage.