

**11146****91-97 TOYOTA PREVIA VAN**

12/5/2012

GROSS LOAD CAPACITY WHEN USED AS A WEIGHT CARRYING HITCH: 2,000 LBS. TRAILER WEIGHT &amp; 200 LBS. TONGUE WEIGHT.

**\*\*\*DO NOT EXCEED VEHICLE MANUFACTURER'S RECOMMENDED TOWING CAPACITY.\*\*\*****WARNING: ALL NON-TRAILER LOADS APPLIED TO THIS PRODUCT MUST BE SUPPORTED BY AUXILIARY STABILIZING STRAPS.****\*\* FAILURE TO PROPERLY SUPPORT NON-TRAILER LOADS WILL VOID PRODUCT WARRANTY\*\***

HAVING INSTALLATION QUESTIONS? CALL TECHNICAL SUPPORT AT 1-800-798-0813

Parts List			
ITEM	QTY	PART NUMBER	DESCRIPTION
1	3	3/8 - 16 x 1 1/4	HEX BOLT
2	5	3/8"	WASHER
3	5	3/8"	LOCK WASHER
4	5	3/8 - 16	HEX NUT
5	2	3/8-16 X 1 1/2	HEX BOLT
6	1	CM-11146-BP	.25 x 1.50 BACKING PLATE

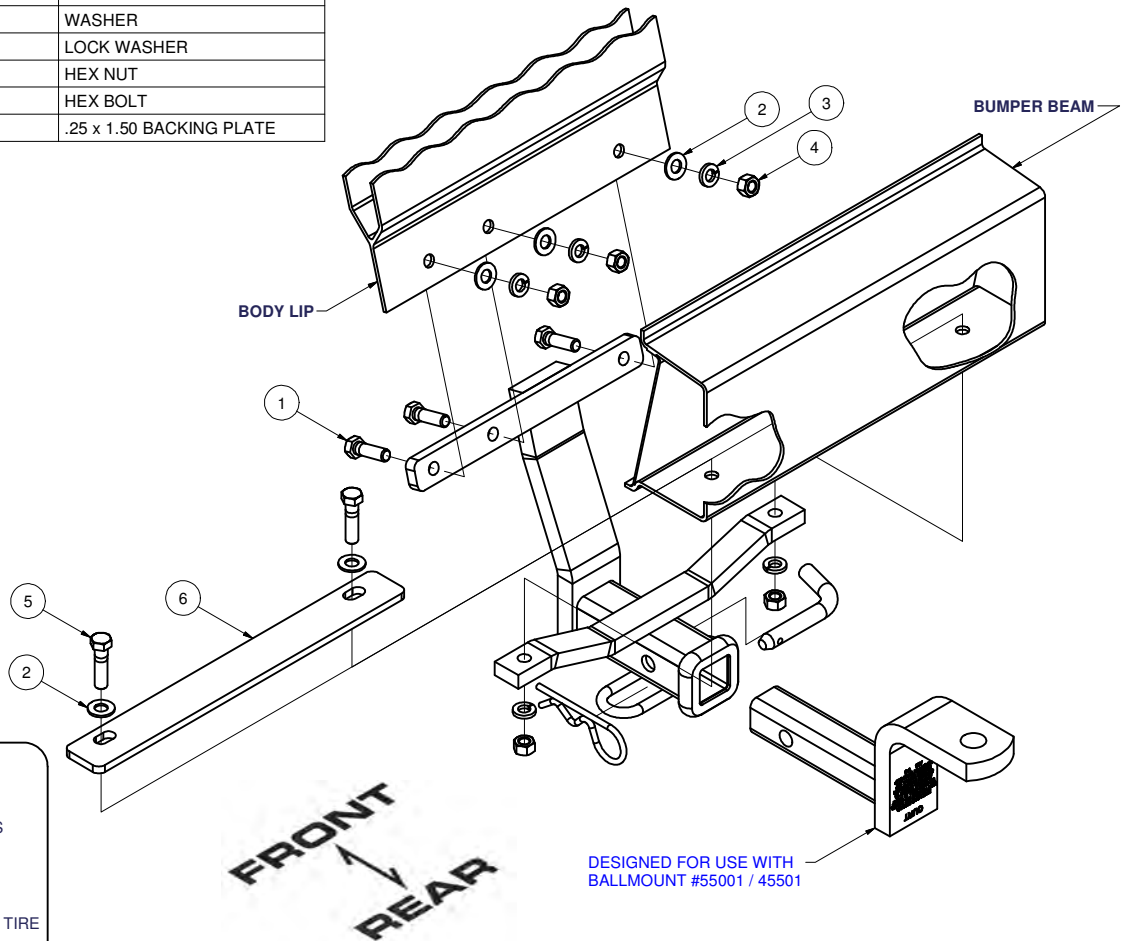

HITCH WEIGHT: 12 LBS.

INSTALL TIME

PROFESSIONAL: 45 MINUTES

NOVICE (DIY): 90 MINUTES

INSTALL NOTES:

- DRILLING REQUIRED
- TEMPORARILY REMOVE SPARE TIRE

**INSTALLATION STEPS**

1. Temporarily remove the spare tire.
2. Hold the hitch in position on the vehicle, centered across the bumper. The hitch brackets mount to the underside of the steel inner bumper and the forward side of the body lip as shown. The hitch will self center as it fits between the bumper fascia bosses. The hitch must fit directly against the steel surfaces; no plastic should be sandwiched between.
3. Mark and drill the bumper and body lip for fasteners as shown.
4. Fasten the hitch to the rear bumper using fasteners provided with the hitch. The bumper reinforcement plate **MUST** be used inside the bumper; opposite the hitch bracket. Washers should be used at reinforcement and body lip as shown.
5. Torque all 3/8" fasteners to 45 lb-ft.

**PERIODICALLY CHECK THIS RECEIVER HITCH TO ENSURE THAT ALL FASTENERS ARE TIGHT AND THAT ALL STRUCTURAL COMPONENTS ARE SOUND.**

Curt Manufacturing Inc., warrants this product to be free of defects in material and/or workmanship at the time of retail purchase by the original purchaser. If the product is found to be defective, Curt Manufacturing Inc., may repair or replace the product, at their option, when the product is returned, prepaid, with proof of purchase. Alteration to, misuse of, or improper installation of this product voids the warranty. Curt Manufacturing Inc.'s liability is limited to repair or replacement of products found to be defective, and specifically excludes liability for incidental or consequential loss or damage.