

**11154****2002 - 2004 ACURA RSX****11/26/2012****GROSS LOAD CAPACITY WHEN USED AS A WEIGHT CARRYING HITCH: 2,000 LBS. TRAILER WEIGHT & 200 LBS. TONGUE WEIGHT.**

\*\*\*DO NOT EXCEED VEHICLE MANUFACTURER'S RECOMMENDED TOWING CAPACITY.\*\*\*

**WARNING: ALL NON-TRAILER LOADS APPLIED TO THIS PRODUCT MUST BE SUPPORTED BY AUXILIARY STABILIZING STRAPS.**

\*\* FAILURE TO PROPERLY SUPPORT NON-TRAILER LOADS WILL VOID PRODUCT WARRANTY\*\*

**HAVING INSTALLATION QUESTIONS? CALL TECHNICAL SUPPORT AT 1-800-798-0813**

Parts List			
ITEM	QTY	PART NUMBER	DESCRIPTION
1	2	7/16-14 x 1 1/2	CARRIAGE BOLT
2	2	CM-SP7	.250 x 1.00 x 2.00" SQUARE HOLE SPACER
3	2	7/16-14	HEX FLANGE NUT
4	1	1/2-13 x 2"	HEX BOLT
5	1	HFN 1213	HEX FLANGE NUT
6	2	CM-438-FW	7/16" FISHWIRE TOOL
7	1	CM-SP128	.375 x 1.50" SPACER

**RUBBER ISOLATOR  
REMOVAL DIAGRAM**

This technique can be used if and Exhaust Hanger Removal Pliers is not available.

Using a 5/8" open end wrench, slide the wrench up to the rubber isolator, cradling the hanger rod as shown. Next place the flat edge of a pry bar between the wrench and the hanger stop or hanger rod. Then simply rotate the pry bar toward the wrench to remove the rubber isolator.

Note: Using a spray lubricant or soapy water on the hanger rod and the rubber isolator helps removal.

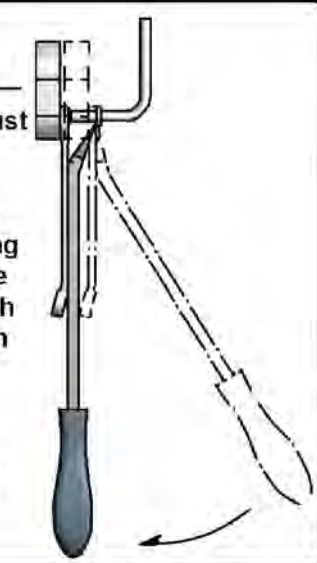
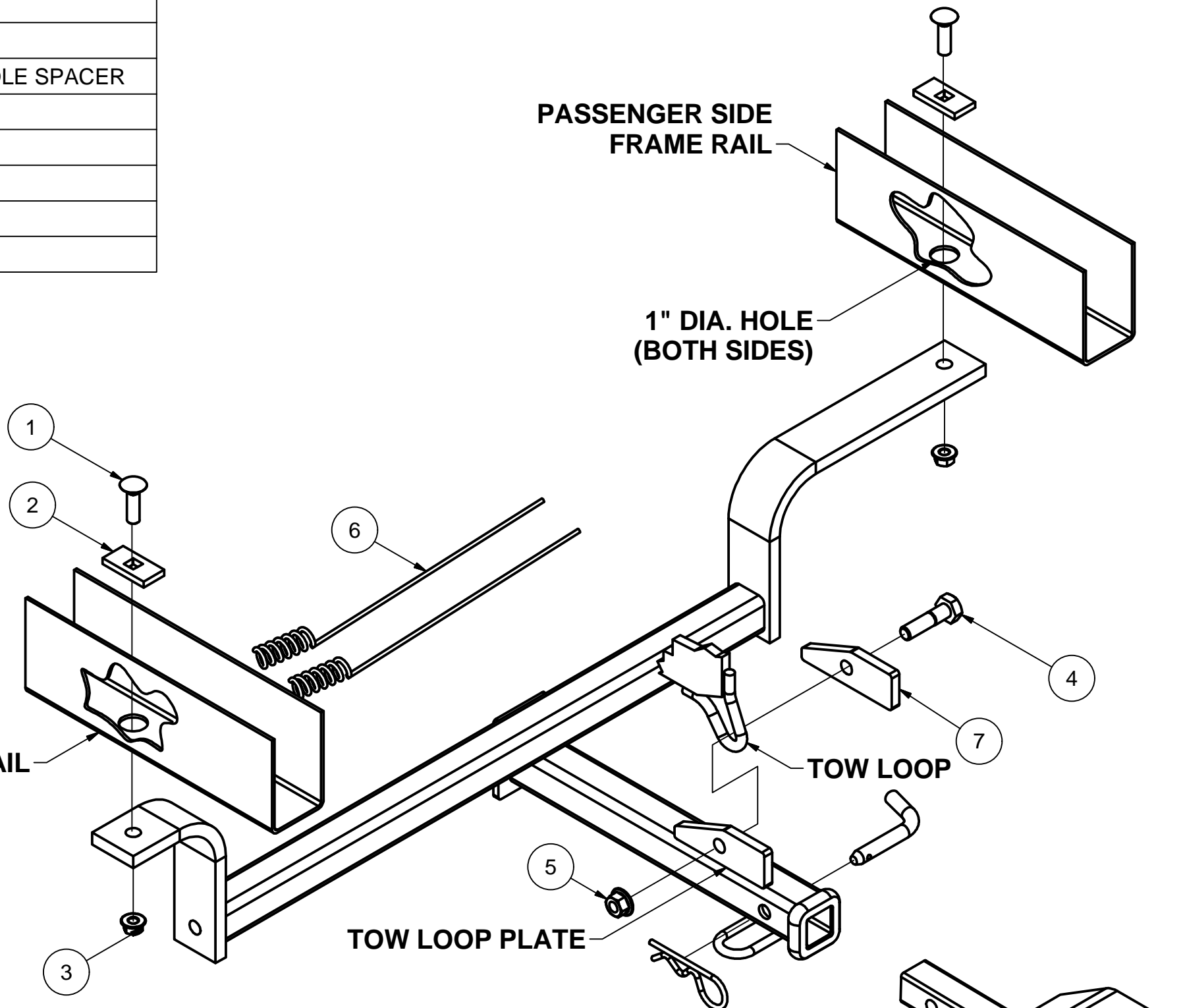
**DRIVER SIDE FRAME RAIL****PASSENGER SIDE  
FRAME RAIL****1" DIA. HOLE  
(BOTH SIDES)****TOW LOOP PLATE****TOW LOOP****DESIGNED FOR USE WITH  
BALL MOUNT # D-55010/ 45510****FRONT  
↑  
REAR****HITCH WEIGHT:** 27 LBS.**INSTALL TIME**

PROFESSIONAL: 20 MINUTES

NOVICE (DIY): 40 MINUTES

**INSTALL NOTES:**

- NO DRILLING REQUIRED
- LOWER EXHAUST
- FISHWIRE HARDWARE

**REVERSE PULL FISHWIRE  
TECHNIQUE**

ATTACH FISHWIRE TO CARRIAGE BOLT AND SLIDE SPACER ONTO FISHWIRE. PUSH THE BOLT THRU THE HOLE FOLLOWED BY THE SPACER (AS SHOWN). PULL BOLT BACK INTO POSITION, PROTRUDING FROM THE FRAME.

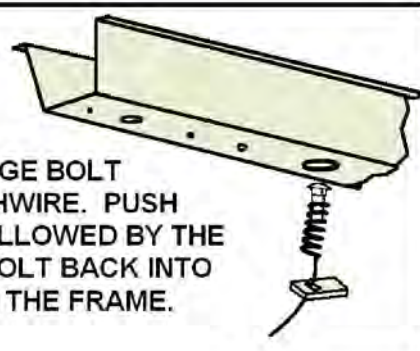
**INSTALLATION STEPS**

1. Temporarily lower the exhaust by disconnecting the (2) rear most hangers. (See Rubber Isolator Removal Diagram.)
2. Reverse Pull Fishwire a 7/16" carriage bolt and CM-SP7 spacer into each of the 1" holes in the frame rail as shown. (Note: Hole enlargement may be required.) (See Reverse Pull Fishwire Technique.)
3. Carefully raise the hitch into position, taking care not to push the bolts back into the frame. Install the remaining 7/16" hardware as shown. Do NOT tighten at this time.
4. Insert a 1/2" bolt through CM-SP128, raise the hitch to the level position and slide bolt through the tow loop and the tow loop plate as shown. Secure with 1/2" flange nut.
5. Torque all 1/2" hardware to 110 ft-lbs and all 7/16" hardware to 70 ft-lbs. Raise the exhaust into position and reinstall the hangers removed in Step 1.

PERIODICALLY CHECK THIS RECEIVER HITCH TO ENSURE THAT ALL FASTENERS ARE TIGHT AND THAT ALL STRUCTURAL COMPONENTS ARE SOUND.

Curt Manufacturing Inc., warrants this product to be free of defects in material and/or workmanship at the time of retail purchase by the original purchaser. If the product is found to be defective, Curt Manufacturing Inc., may repair or replace the product, at their option, when the product is returned, prepaid, with proof of purchase. Alteration to, misuse of, or improper installation of this product voids the warranty. Curt Manufacturing Inc.'s liability is limited to repair or replacement of products found to be defective, and specifically excludes liability for incidental or consequential loss or damage.

249413 / 247413