



Safety glasses should be worn at all times while installing this product.

YEARS: 2012-PRESENT

MAKE: FORD

MODEL: FOCUS - EXCLUDE ST & ELECTRIC

STYLE: SEDAN & HATCHBACK

WARNING: NEVER EXCEED YOUR VEHICLE MANUFACTURER'S RECOMMENDED TOWING CAPACITY

WEIGHT CARRYING:
 TRAILER WEIGHT: 2,000 LBS.
 TONGUE WEIGHT: 200 LBS.

WARNING:
 WE RECOMMEND THE USE OF 18050 STABILIZING STRAPS FOR ALL NON-TRAILER (WHEEL-LESS) LOADS. PLEASE SEE THE CURT CATALOG OR VISIT US ONLINE AT WWW.CURTMFG.COM FOR FURTHER INFORMATION.

INSTALLATION TIME: 20 MIN.

THE INSTALL TIME LISTED IS FOR PROFESSIONAL INSTALLERS. IF YOU ARE HESITANT TO UNDERTAKE THIS TASK ON YOUR OWN, CONTACT AN AUTHORIZED CURT INSTALLER FOR ADDITIONAL ASSISTANCE.

INSTALLATION REQUIRES:

RATCHET	TORQUE WRENCH	POWER DRILL
DIE GRINDER	DRILL BIT 15/32"	6" SOCKET EXTENSION
SOCKET 11/16" 13mm	SAFETY GLASSES	

INSTALLATION TIPS:

- BEFORE YOU BEGIN INSTALLATION, READ ALL INSTRUCTIONS THOROUGHLY.
- TO EASE INSTALLATION, 2 PEOPLE MAY BE REQUIRED.
- USING PROPER TOOLS WILL GREATLY IMPROVE THE QUALITY OF THE INSTALL AND REDUCE THE TIME REQUIRED.
- NEED HELP OR HAVE SOME QUESTIONS? CALL TECHNICAL SUPPORT AT 800.798.0813

LEVEL OF DIFFICULTY: MODERATE

EASY	MODERATE	CHALLENGING
	- DRILLING REQUIRED	
	- FISHWIRE DIAGRAM	

VEHICLE PHOTO:



REPRESENTATIVE PHOTO

HITCH ILLUSTRATION:

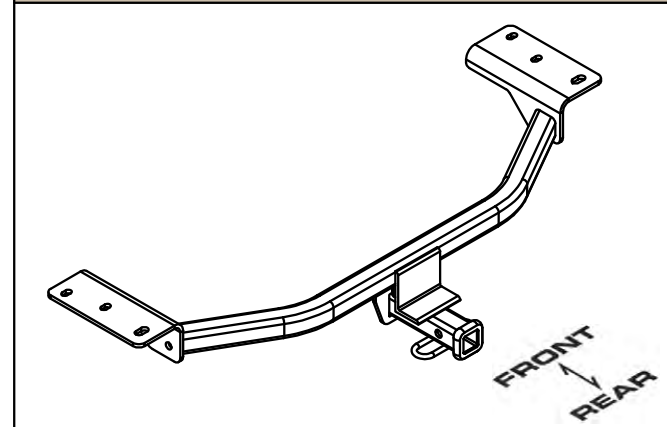

MAKE SURE YOUR HITCH MATCHES

PERIODICALLY CHECK THIS RECEIVER HITCH TO ENSURE ALL FASTENERS ARE TIGHT AND ALL STRUCTURAL COMPONENTS ARE SOUND

CURT Manufacturing LLC. warrants this product to be free of defects in material and/or workmanship at the time of retail purchase by the original purchaser. If the product is found to be defective, Curt Manufacturing LLC. may repair or replace the product at their option, when the product is returned, prepaid, with proof of purchase. Alteration to, misuse of, or improper installation of this product voids the warranty. Curt Manufacturing LLC.'s liability is limited to repair or replacement of products found to be defective, and specifically excludes liability for incidental or consequential loss or damage.

For more information log onto www.curtmfg.com, & for helpful towing tips log onto www.hitchinfo.com

INSTALLATION WALKTHROUGH:

Parts List			
ITEM	QTY	PART NUMBER	DESCRIPTION
1	4	M8-1.25 x 40	HEX BOLT
2	4	3/8"	CONICAL TOOTHED WASHER
3	2	7/16-14	HEX FLANGE NUT
4	2	CM-SP7	.250 x 1.00 x 2.00" SQUARE HOLE SPACER
5	2	7/16-14 x 1 1/2	CARRIAGE BOLT
6	2	7_16 FISHWIRE	7/16" FISHWIRE

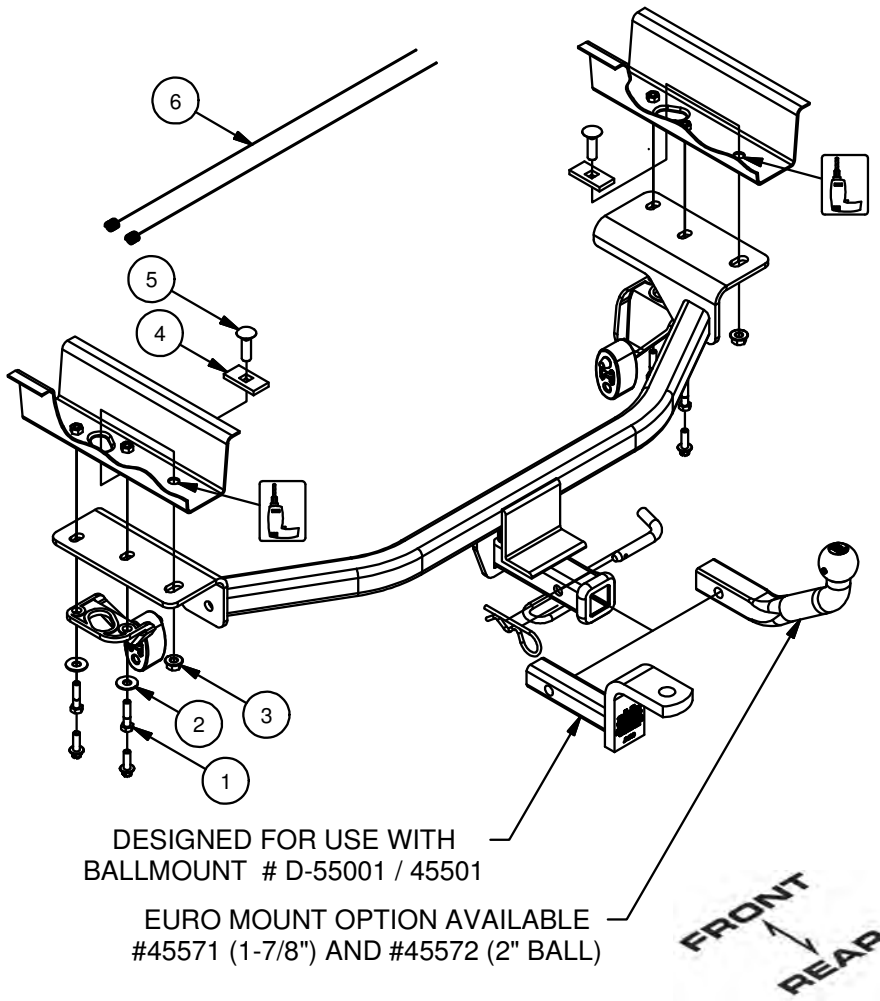

1. Remove (4) bolts and lower the (2) rear exhaust brackets, return bolts to owner.

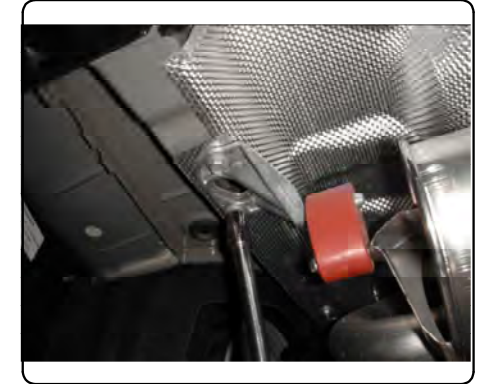

2. Raise hitch into position and temporarily secure to existing weldnuts in the frame rails using M8-1.25 hex bolts and 3/8" conical toothed washers. Using the hitch as a template mark drill location on both sides. Lower hitch and drill holes.

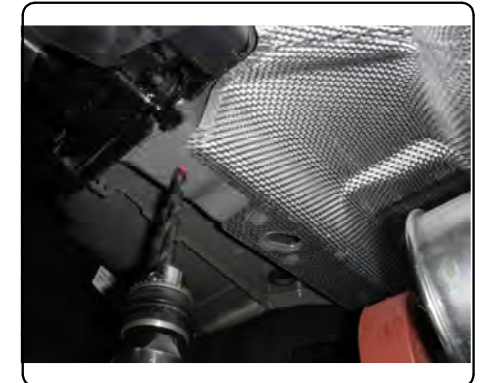
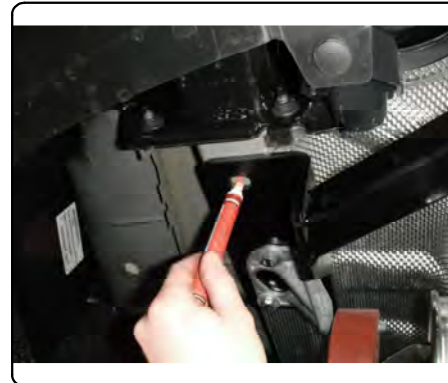

INSTALLATION WALKTHROUGH:

3. Enlarge access holes to allow 7/16"-14 carriage bolts and SP7 spacers to pass through. Fishwire 7/16"-14 carriage bolts and SP7 spacers through the enlarged access holes and out the holes drilled in Step (2).

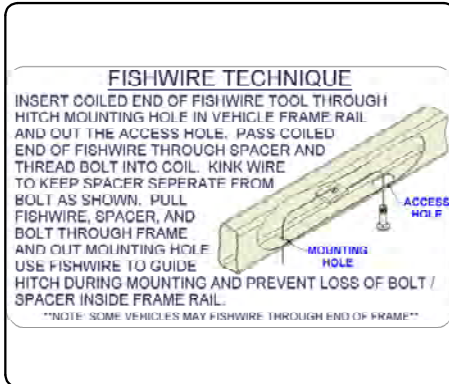

4. Raise hitch into position and loosely secure the rear most holes with 7/16"-14 flange nuts. Sandwich the hitch side plates between the frame rails and the exhaust brackets, secure with M8-1.25 hex bolts and 3/8" conical toothed washers.

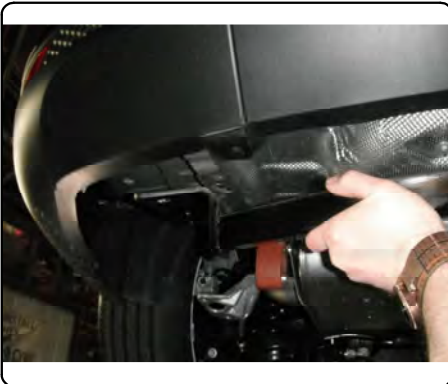

5. Torque all M8 hardware to 23 ft-lbs.
Torque all 7/16" hardware to 70 ft-lbs.



Install Complete



11158**FORD FOCUS - EXCLUDE ST & ELECTRIC**

9/24/2012

GROSS LOAD CAPACITY WHEN USED AS A WEIGHT CARRYING HITCH: 2,000 LBS. TRAILER WEIGHT & 200 LBS. TONGUE WEIGHT.

*****DO NOT EXCEED VEHICLE MANUFACTURER'S RECOMMENDED TOWING CAPACITY.*******WARNING: ALL NON-TRAILER LOADS APPLIED TO THIS PRODUCT MUST BE SUPPORTED BY 18050 STABILIZING STRAPS.****** FAILURE TO PROPERLY SUPPORT NON-TRAILER LOADS WILL VOID PRODUCT WARRANTY******HAVING INSTALLATION QUESTIONS? CALL TECHNICAL SUPPORT AT 1-800-798-0813**

		Parts List	
ITEM	QTY	PART NUMBER	DESCRIPTION
1	4	M8-1.25 x 40	HEX BOLT
2	4	3/8"	CONICAL TOOTHED WASHER
3	2	7/16-14	HEX FLANGE NUT
4	2	CM-SP7	.250 x 1.00 x 2.00" SQUARE HOLE SPACER
5	2	7/16-14 x 1 1/2	CARRIAGE BOLT
6	2	7_16 FISHWIRE	7/16" FISHWIRE

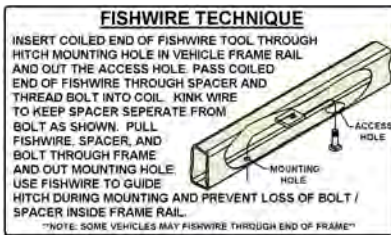

TOOLS REQUIRED
RATCHET
TORQUE WRENCH
DRILL
DIE GRINDER
6" EXTENSION
15/32" DRILL BIT
11/16" SOCKET
13mm SOCKET

HITCH WEIGHT: 28 LBS.

INSTALL TIME

PROFESSIONAL: 20 MINUTES

NOVICE (DIY): 40 MINUTES

INSTALL NOTES:

- DRILLING REQUIRED
- FISHWIRE HARDWARE

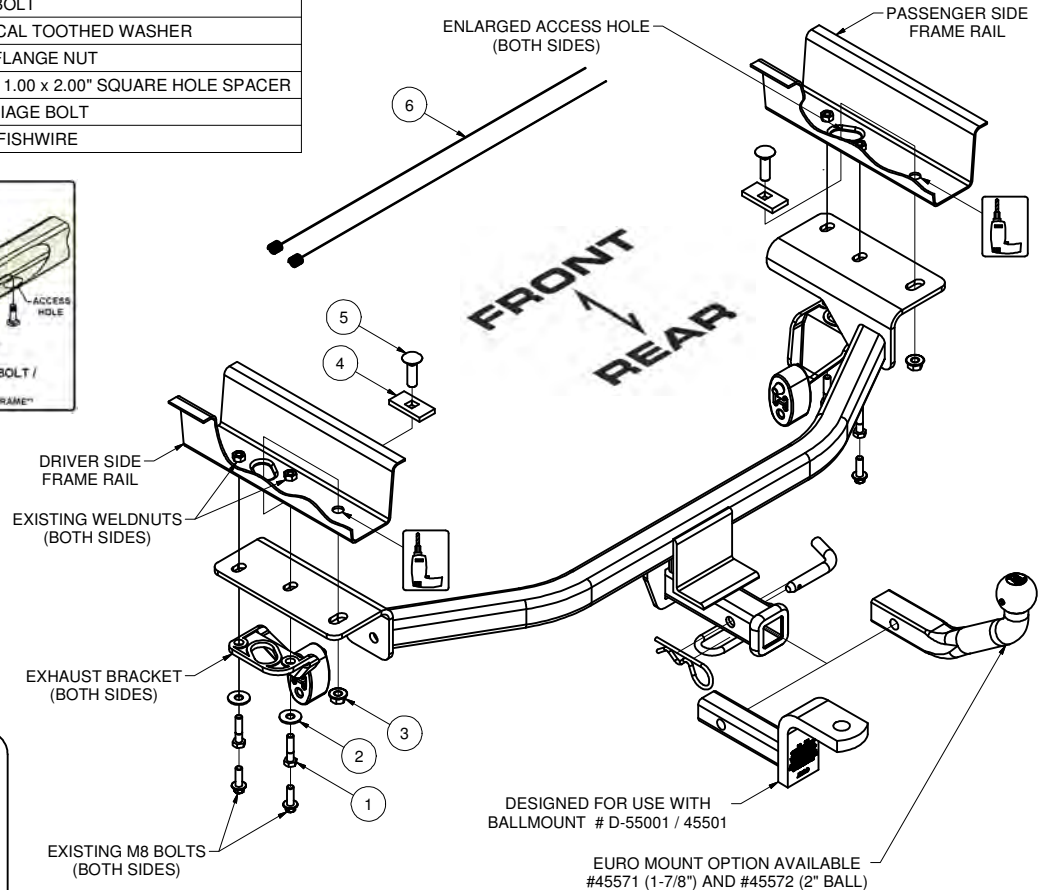
**INSTALLATION STEPS**

1. Remove (4) bolts and lower the (2) rear exhaust brackets, return bolts to owner.
2. Raise hitch into position and temporarily secure to existing weldnuts in the frame rails using M8-1.25 hex bolts and 3/8" conical toothed washers.
3. Using the hitch as a template mark drill location on both sides.
4. Lower hitch and drill holes marked in Step (3).
5. Enlarge access holes to allow 7/16" carriage bolts and SP7 spacers to pass through.
6. Fishwire 7/16"-14 carriage bolts and SP7 spacers through the enlarged access holes and out the holes drilled in Step (4). (See Fishwire Technique)
7. Raise hitch into position and loosely secure the rear most holes with 7/16"-14 flange nuts. Sandwich the hitch side plates between the frame rails and the exhaust brackets, secure with M8-1.25 hex bolts and 3/8" conical toothed washers.
8. Torque all M8 hardware to 23 ft-lbs.
Torque all 7/16" hardware to 70 ft-lbs.

PERIODICALLY CHECK THIS RECEIVER HITCH TO ENSURE THAT ALL FASTENERS ARE TIGHT AND THAT ALL STRUCTURAL COMPONENTS ARE SOUND.

Curt Manufacturing LLC., warrants this product to be free of defects in material and/or workmanship at the time of retail purchase by the original purchaser. If the product is found to be defective, Curt Manufacturing LLC., may repair or replace the product, at their option, when the product is returned, prepaid, with proof of purchase. Alteration to, misuse of, or improper installation of this product voids the warranty. Curt Manufacturing LLC.'s liability is limited to repair or replacement of products found to be defective, and specifically excludes liability for incidental or consequential loss or damage.