

11191

90-94 MITSUBISHI ECLIPSE, 90-94 EAGLE TALON, 90-94 PLYMOUTH LASER

12/10/2012

GROSS LOAD CAPACITY WHEN USED AS A WEIGHT CARRYING HITCH: 2,000 LBS. TRAILER WEIGHT & 200 LBS. TONGUE WEIGHT.

DO NOT EXCEED VEHICLE MANUFACTURER'S RECOMMENDED TOWING CAPACITY.

WARNING: ALL NON-TRAILER LOADS APPLIED TO THIS PRODUCT MUST BE SUPPORTED BY 18050 STABILIZING STRAPS.

** FAILURE TO PROPERLY SUPPORT NON-TRAILER LOADS WILL VOID PRODUCT WARRANTY**

HAVING INSTALLATION QUESTIONS? CALL TECHNICAL SUPPORT AT 1-800-798-0813

Parts List			
ITEM	QTY	PART NUMBER	DESCRIPTION
1	1	CM-438-FW	7/16" FISHWIRE TOOL
2	2	CM-SP11	.250 x 1.00 x 2.50" SQUARE HOLE SPACER
3	2	HFN3816	HEX FLANGE NUT
4	2	3/8-16 x 1 1/2	CARRIAGE BOLT
5	4	7/16-14	HEX FLANGE NUT
6	2	7/16-14 x 1.63 x 2.50 C-C	SQ. U-BOLT

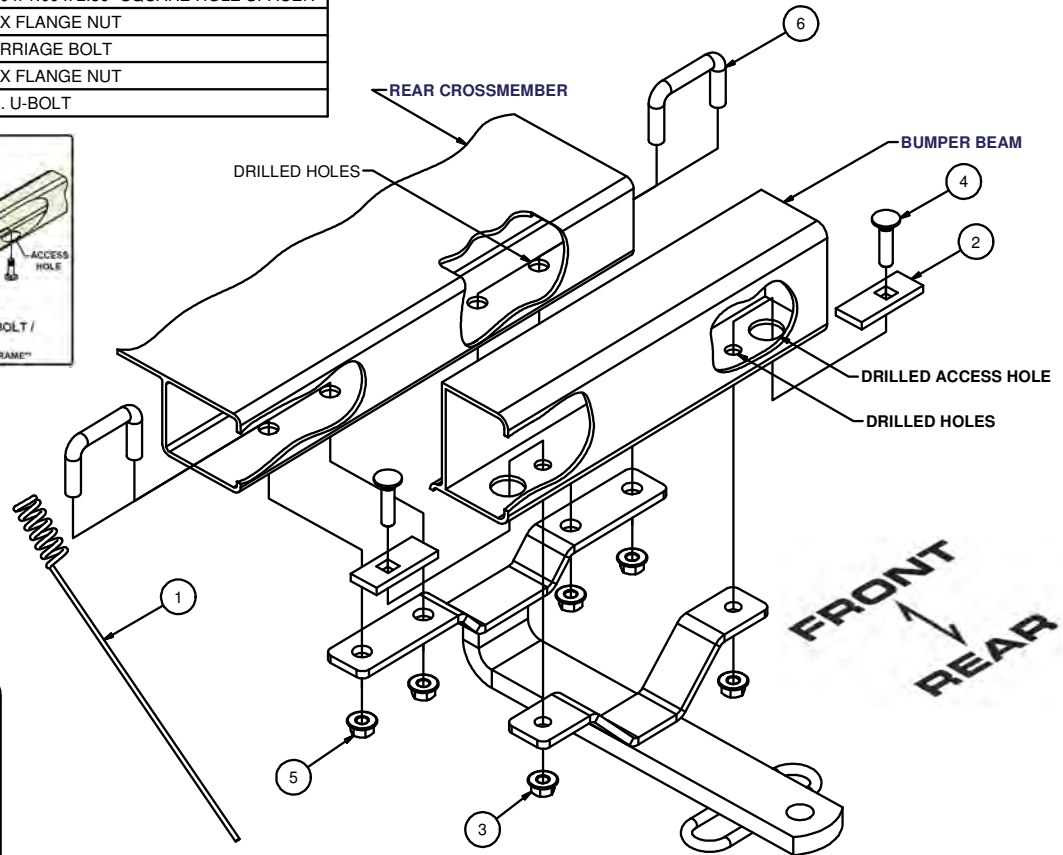
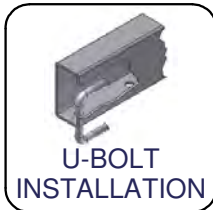
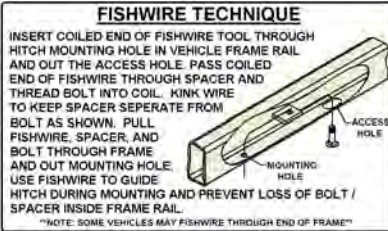

HITCH WEIGHT: 8 LBS.

INSTALL TIME

PROFESSIONAL: 30 MINUTES

NOVICE (DIY): 60 MINUTES

INSTALL NOTES:

- DRILLING REQUIRED
- FACIA TRIMMING REQUIRED

INSTALLATION STEPS

1. Measure and mark the vehicle's centerline at the bottom of the rear bumper. Hold hitch in position on the vehicle and mark fascia at the bottom of bumper for hitch bracket clearance. Trim away fascia. Note that this hitch bolts directly under the boxed in section of metal bumper beam as shown, not on the edge lip that extends from the bumper beam.
2. Position hitch on vehicle centered and square, and check for enough hitch ball/bumper clearance. Using the hitch as a template mark and centerpunch the vehicle's bumper beam and crossmember for mounting holes. Drill bumper beam for 3/8" diameter bolts and the crossmember for 7/16" diameter bolts.
3. Fishwire 3/8" fasteners and CM-SP11 inside bumper beam extending through 7/16" holes in beam. If access holes do not exist, a separate 1" diameter or larger access hole will need to be drilled in bumper beam. Place (2) U-bolts into holes in crossmember.
4. Carefully place hitch over the 3/8" fasteners and U-bolts without pushing the fasteners out of place. Secure hitch with hex flange nuts as shown.
5. Torque all 7/16" fasteners to 70 lb-ft, and all 3/8" fasteners to 45 lb-ft.

PERIODICALLY CHECK THIS RECEIVER HITCH TO ENSURE THAT ALL FASTENERS ARE TIGHT AND THAT ALL STRUCTURAL COMPONENTS ARE SOUND.

Curt Manufacturing Inc., warrants this product to be free of defects in material and/or workmanship at the time of retail purchase by the original purchaser. If the product is found to be defective, Curt Manufacturing Inc., may repair or replace the product, at their option, when the product is returned, prepaid, with proof of purchase. Alteration to, misuse of, or improper installation of this product voids the warranty. Curt Manufacturing Inc.'s liability is limited to repair or replacement of products found to be defective, and specifically excludes liability for incidental or consequential loss or damage.