

**11193****95-98 EAGLE TALON / 95-99 MITSUBISHI ECLIPSE**

12/5/2012

GROSS LOAD CAPACITY WHEN USED AS A WEIGHT CARRYING HITCH: 2,000 LBS. TRAILER WEIGHT &amp; 200 LBS. TONGUE WEIGHT.

**\*\*\*DO NOT EXCEED VEHICLE MANUFACTURER'S RECOMMENDED TOWING CAPACITY.\*\*\***

WARNING: ALL NON-TRAILER LOADS APPLIED TO THIS PRODUCT MUST BE SUPPORTED BY 18050 STABILIZING STRAPS.

**\*\* FAILURE TO PROPERLY SUPPORT NON-TRAILER LOADS WILL VOID PRODUCT WARRANTY\*\***

HAVING INSTALLATION QUESTIONS? CALL TECHNICAL SUPPORT AT 1-800-798-0813

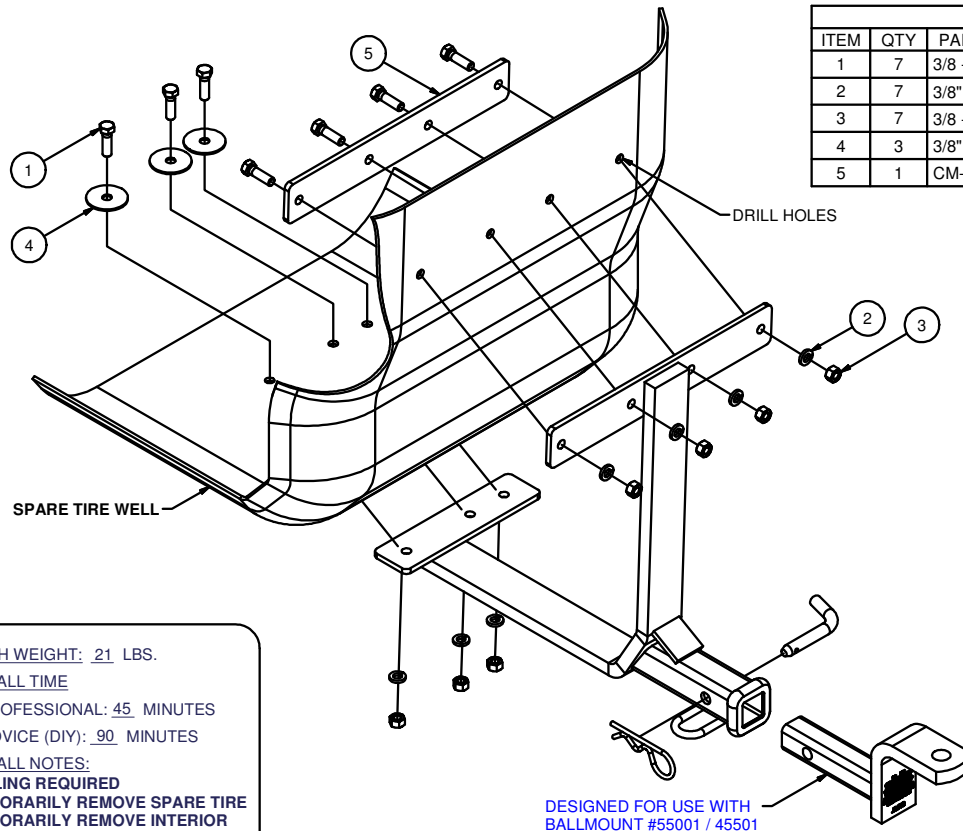

Parts List			
ITEM	QTY	PART NUMBER	DESCRIPTION
1	7	3/8 - 16 x 1 1/4	HEX BOLT
2	7	3/8"	LOCK WASHER
3	7	3/8 - 16	HEX NUT
4	3	3/8"	FENDER WASHER
5	1	CM-11193-TB2	.25 x 2.00 TAIL BRACKET

HITCH WEIGHT: 21 LBS.

INSTALL TIME

PROFESSIONAL: 45 MINUTES

NOVICE (DIY): 90 MINUTES

INSTALL NOTES:

- DRILLING REQUIRED
- TEMPORARILY REMOVE SPARE TIRE
- TEMPORARILY REMOVE INTERIOR PANEL

**INSTALLATION STEPS**

1. This hitch mounts to the rear of the trunk well behind the bumper and to the bottom of the spare tire well.
2. Temporarily remove the spare tire and clear the tire well. Temporarily remove rearward interior plastic trim panel by pulling it out at its bottom and then up along the edge of the door jam. Remove (2) screws fastening the bumper fascia to the spare tire well, and remove (2) pillips head screws holding the fascia to the bumper.
3. Lift the hitch into position on the car and check for center. It may be necessary to bend the center fascia bracket out of the way. It may also be necessary to temporarily move some of the cables running in the rear of the the trunk pan prior to drilling for the fasteners.
4. Check that the hitch is square and level. Using the hitch as a template, drill holes for fasteners in spare tire well. Also drill center two holes for fasteners using the access panel behind the license plate. Install fasteners and the backing plate inside the car as shown. Fender washers are also placed inside the tire well.
5. Using the backing plate as a template, drill the remaining (2) holes from inside the car and install fasteners.
6. Torque all 3/8" fasteners to 45 lb-ft.
7. Trim fascia as necessary and refasten to fascia bracket. Reinstall the rear interior trim panel and spare tire.

**PERIODICALLY CHECK THIS RECEIVER HITCH TO ENSURE THAT ALL FASTENERS ARE TIGHT AND THAT ALL STRUCTURAL COMPONENTS ARE SOUND.**

Curt Manufacturing Inc., warrants this product to be free of defects in material and/or workmanship at the time of retail purchase by the original purchaser. If the product is found to be defective, Curt Manufacturing Inc., may repair or replace the product, at their option, when the product is returned, prepaid, with proof of purchase. Alteration to, misuse of, or improper installation of this product voids the warranty. Curt Manufacturing Inc.'s liability is limited to repair or replacement of products found to be defective, and specifically excludes liability for incidental or consequential loss or damage.