

1120792-00 HONDA CIVIC 2 & 4DR, 97-00 ACURA 1.6 EL (CANADA ONLY),
2001 ACURA 1.7 EL

9/28/2012

**GROSS LOAD CAPACITY WHEN USED AS A WEIGHT CARRYING HITCH: 2000 LBS. TRAILER WEIGHT & 200 LBS. TONGUE WEIGHT.
DO NOT EXCEED VEHICLE MANUFACTURER'S RECOMMENDED TOWING CAPACITY.**

| | | Parts List | |
|------|-----|------------------------|--|
| ITEM | QTY | PART NUMBER | DESCRIPTION |
| 1 | 1 | 1/2" | FISHWIRE TOOL |
| 2 | 1 | 3/8 - 16 x 1.00 x 1.88 | U-BOLT |
| 3 | 2 | 1/2 - 13 x 2" | CARRIAGE BOLT |
| 4 | 2 | HFN 1213 | HEX FLANGE NUT |
| 5 | 2 | HFN3816 | HEX FLANGE NUT |
| 6 | 2 | CM-SP1 | .250 x 1.50 x 2.00" SQUARE HOLE SPACER |
| 7 | 4 | CM-SP31 | .250 x 1.75 x 2.00" U-SHAPE SPACER |

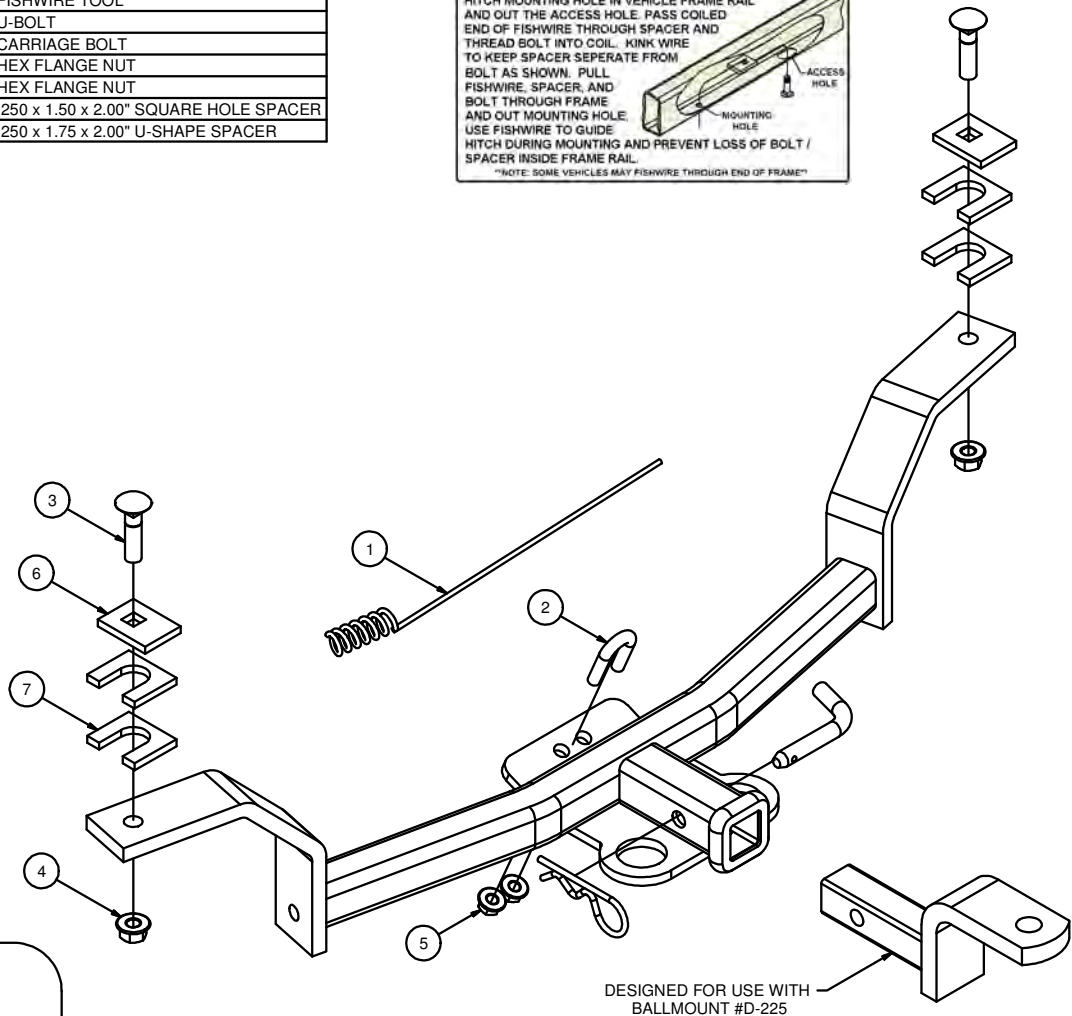
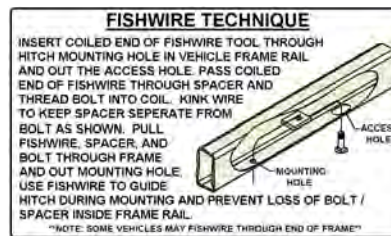

HITCH WEIGHT: 25.5 LBS.

INSTALL TIME

PROFESSIONAL: 45 MINUTES

NOVICE (DIY): 90 MINUTES

INSTALL NOTES:

DESIGNED FOR USE WITH
BALLMOUNT #D-225**INSTALLATION STEPS**

- 1) Fishwire carriage bolt and spacer through end of frame rail. Pull carriage bolt and spacer through separate by putting a kink in the fishwire (as shown in the FISHWIRE TECHNIQUE DIAGRAM).
- 2) Raise hitch into position and loosely install 3/8" U-bolt through tow hook and mounting plate at back of hitch and fasten with flange nuts.
- 3) Insert U-shaped block between hitch side arm and vehicle frame, each side. Be careful not to sandwich and crush turned-down edge of frame hole. Use second U-shaped block, if needed, so that receiver tube is level or tilted upward.
- 4) Torque 3/8" fasteners to 45 LB.-FT. and 1/2" fasteners to 110 LB.-FT.

PERIODICALLY CHECK THIS RECEIVER HITCH TO ENSURE THAT ALL FASTENERS ARE TIGHT AND THAT ALL STRUCTURAL COMPONENTS ARE SOUND.

Curt Manufacturing Inc., warrants this product to be free of defects in material and/or workmanship at the time of retail purchase by the original purchaser. If the product is found to be defective, Curt Manufacturing Inc., may repair or replace the product, at their option, when the product is returned, prepaid, with proof of purchase. Alteration to, misuse of, or improper installation of this product voids the warranty. Curt Manufacturing Inc.'s liability is limited to repair or replacement of products found to be defective, and specifically excludes liability for incidental or consequential loss or damage.