



Safety glasses should be worn at all times while installing this product.

YEARS: 2012

MAKE: HYUNDAI

MODEL: ACCENT (EXCLUDES GS)

STYLE: SEDAN

WARNING: NEVER EXCEED YOUR VEHICLE MANUFACTURER'S RECOMMENDED TOWING CAPACITY

WEIGHT CARRYING:
 TRAILER WEIGHT: 2,000 LBS.
 TONGUE WEIGHT: 200 LBS.

WARNING:
 WE RECOMMEND THE USE OF 18050 STABILIZING STRAPS FOR ALL NON-TRAILER (WHEEL-LESS) LOADS. PLEASE SEE THE CURT CATALOG OR VISIT US ONLINE AT WWW.CURTMFG.COM FOR FURTHER INFORMATION.





INSTALLATION TIME: 30 MIN.
 THE INSTALL TIME LISTED IS FOR PROFESSIONAL INSTALLERS. IF YOU ARE HESITANT TO UNDERTAKE THIS TASK ON YOUR OWN, CONTACT AN AUTHORIZED CURT INSTALLER FOR ADDITIONAL ASSISTANCE.

INSTALLATION TIPS:



- BEFORE YOU BEGIN INSTALLATION, READ ALL INSTRUCTIONS THOROUGHLY.
- TO EASE INSTALLATION, 2 PEOPLE MAY BE REQUIRED.
- USING PROPER TOOLS WILL GREATLY IMPROVE THE QUALITY OF THE INSTALL AND REDUCE THE TIME REQUIRED.
- NEED HELP OR HAVE SOME QUESTIONS? CALL TECHNICAL SUPPORT AT 800.798.0813



INSTALLATION REQUIRES:

| | | |
|--|--|--|
|  RATCHET |  TORQUE WRENCH |  11/16" 9/16" SOCKET |
|  SAFETY GLASSES | | |
| | | |
| | | |

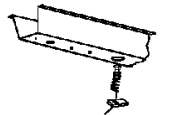
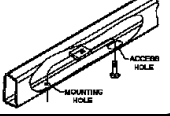
LEVEL OF DIFFICULTY: EASY

| EASY | MODERATE | CHALLENGING |
|---|---|-------------|
|  PART REMOVAL | Remove (2) rubber plugs (if present) | |
|  | "reverse pull" fishwire (2) bolts and (2) spacers | |
|  ACCESS HOLE MOUNTING HOLE | Fishwire (2) bolts and (2) spacers | |
|  | No drilling required | |
| | | |

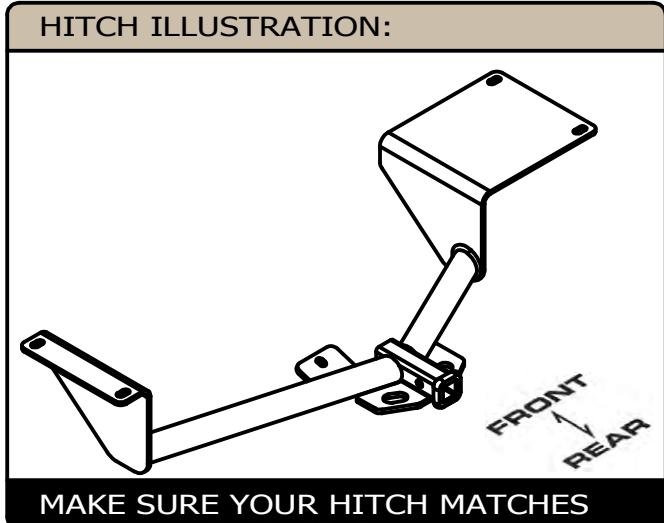

PERIODICALLY CHECK THIS RECEIVER HITCH TO ENSURE ALL FASTENERS ARE TIGHT AND ALL STRUCTURAL COMPONENTS ARE SOUND

CURT Manufacturing LLC. warrants this product to be free of defects in material and/or workmanship at the time of retail purchase by the original purchaser. If the product is found to be defective, Curt Manufacturing LLC. may repair or replace the product at their option, when the product is returned, prepaid, with proof of purchase. Alteration to, misuse of, or improper installation of this product voids the warranty. Curt Manufacturing LLC.'s liability is limited to repair or replacement of products found to be defective, and specifically excludes liability for incidental or consequential loss or damage.

For more information log onto www.curtmfg.com, & for helpful towing tips log onto www.hitchinfo.com

INSTALLATION WALKTHROUGH:

| Parts List | | | |
|------------|-----|-----------------|--|
| ITEM | QTY | PART NUMBER | DESCRIPTION |
| 1 | 4 | 7/16-14 x 1 1/4 | CARRIAGE BOLT |
| 2 | 4 | 7/16-14 | HEX FLANGE NUT |
| 3 | 4 | CM-SP19 | .250 x 1.25 x 3.00" SQUARE HOLE SPACER |
| 4 | 1 | CM-SP34 | .188 x 1.50 x 3.00" ROUND HOLE SPACER |
| 5 | 1 | 3/8-16 X 1 1/2 | HEX BOLT |
| 6 | 1 | 3/8" | WASHER |
| 7 | 1 | HFN3816 | HEX FLANGE NUT |
| 8 | 2 | 7_16 FISHWIRE | 7/16" FISHWIRE |

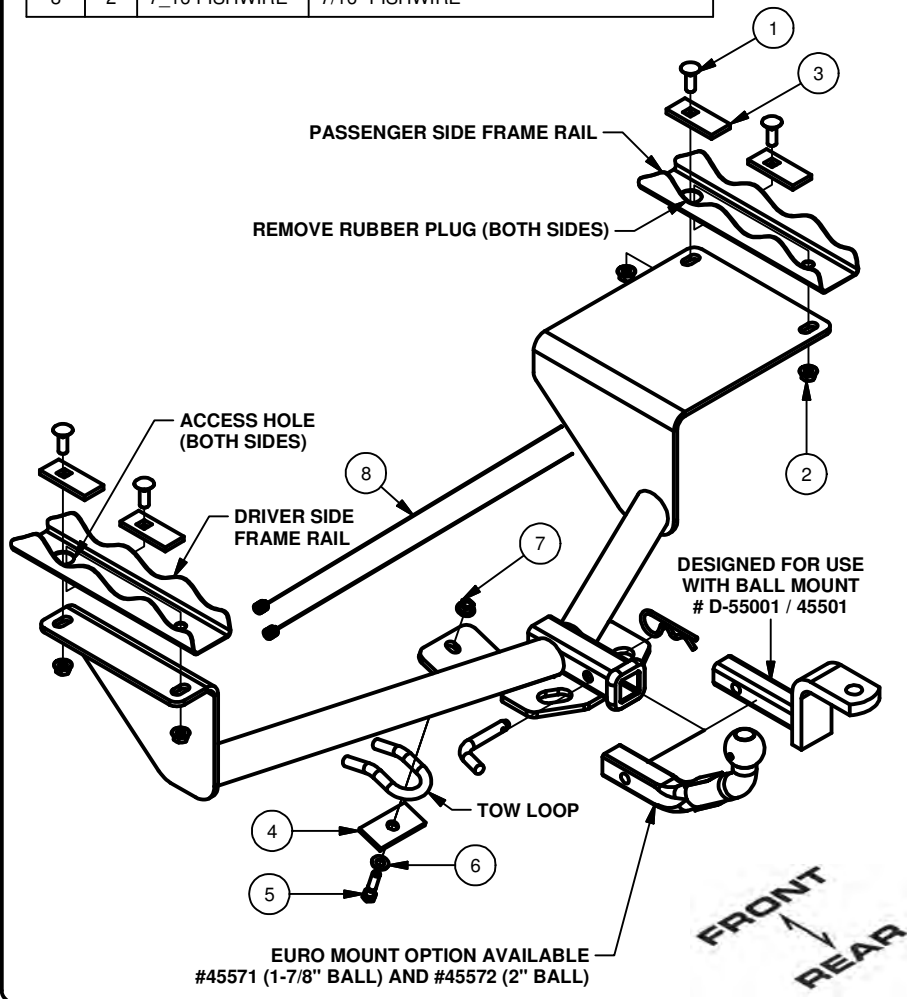

1. if present, Remove rubber plugs from frame holes and return to owner.



2. Fishwire (1) 7/16" carriage bolt and (1) CM-SP19 spacer through the access hole into the rearward hole on both sides. Fishwire (1) 7/16" carriage bolt and (1) CM-SP19 spacer into the access hole on each side.



INSTALLATION WALKTHROUGH:

3. Raise the hitch into position.

NOTE: The tow loop mounting tab will rest on top of the tow loop.

Be careful not to push the carriage bolts back into the frame. Loosely install (4) 7/16" hex flange nuts.



4. Install the remaining 3/8" hardware with (1) CM-SP34 spacer onto the vehicle tow loop.



5. Torque all 3/8" fasteners to 30 lb-ft and all 7/16" fasteners to 50 lb-ft.



Hitch shown fully installed

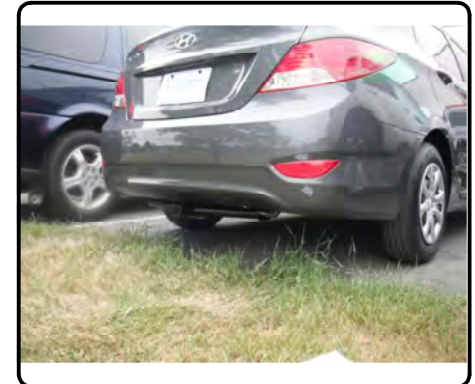

TOWING SAFETY INFORMATION

Gross Trailer Weight / GTW

The Gross Trailer Weight is the weight of the trailer & cargo. Measure this by putting the fully loaded trailer on a vehicle scale.

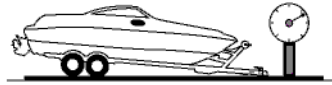

Tongue Weight / TW

The downward force that is exerted on the hitch ball by the coupler. The tongue weight will vary depending on where the load is positioned in relationship to the trailer axle(s). To measure the tongue weight, use either a commercial scale or a bathroom scale with the coupler at towing height. When using a bathroom scale with heavier tongue weights, use the method shown and multiply the scale reading by 3.

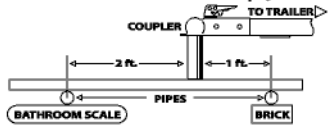

Weight Carrying / WC

The total weight of both the trailer and the cargo inside. Never exceed the weight capacity of your trailer hitch.

Weight Distribution / WD

Used to balance the weight of the cargo between the front and rear wheels throughout the trailer, allowing for better steering, braking, and level riding.



Sway Control

A device used to reduce the lateral movements of the trailer that are caused by the wind. This works in conjunction with a weight distribution hitch. Do not use this on a class 1 or 2 hitch, or with surge brakes.

How Much Can You Safely Tow?

| TONGUE WEIGHT (lb) | 1000 | 2000 | 3000 | 4000 | 5000 | 6000 | 7000 | 8000 | 10,000 | 12,000 |
|---|--|------|------|------|------|------|------|------|--------|--------|
| Tongue weight should be about 10 to 15 percent of the gross trailer weight. | | | | | | | | | | |
| TRAILER TYPE | <div style="display: flex; justify-content: space-between;"> <div style="width: 20%;">CLASS 1</div> <div style="width: 20%;">CLASS 2</div> <div style="width: 20%;">CLASS 3</div> <div style="width: 20%;">CLASS 4</div> <div style="width: 20%;">CLASS 5</div> </div> | | | | | | | | | |
| Camper | 11' | 12' | 13' | 14' | 15' | 16' | | | | |
| lbs. | 1100 | 1200 | 1300 | 1400 | 1500 | 1600 | | | | |
| Vacation | 18' | 16' | 18' | 20' | 22' | 24' | 26' | 28' | 30' | 32' |
| lbs. | 2100 | 2400 | 2700 | 3000 | 3300 | 3600 | 3900 | 4200 | 4500 | 4800 |
| Vacation | 18' | 16' | 18' | 20' | 22' | 24' | 26' | 28' | 30' | 32' |
| lbs. | 2800 | 3200 | 3600 | 4000 | 4400 | 4800 | 5200 | 5600 | 6000 | 6400 |
| 5th Wheel | | | | | | | | | | |

Refer to owner's manual for towing capabilities and limitations.

Ball Mount

The ball mount is placed inside the opening of the receiver hitch which is mounted to the vehicle. Make sure a hitch pin and clip is properly securing the ball mount to the receiver hitch before you begin towing.

- A: Rise. B: Drop. C: Hole Size. D: Length.

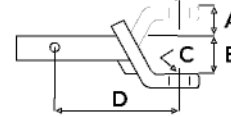

Trailer Ball

The connection from the hitch to the trailer. There are many factors that determine the correct hitch ball:

- Number one is the hitch ball's gross trailer weight rating.
- The mounting platform must be at least 3/8" thick.
- The hole diameter must not be more than 1/16" larger than the threaded shank.
- Every time you tow, check the nut and lock washer to make sure they are fastened securely.
- A: Ball Dia. B: Shank Length. C: Shank Dia. D: Shank Rise.

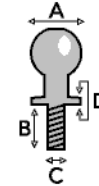

Coupler

The component that is placed over the trailer ball to connect the vehicle to the trailer. Be sure that the coupler size matches the size of the hitch ball and that the coupler handle is securely fastened. To determine what size hitch ball you need for your application you will need to know the size of coupler that is on the trailer. Be sure your coupler is properly adjusted to the ball you are using.

NOTE: For added security the use of safety devices such as Coupler Safety Pins and Locks is strongly recommended.

Safety Chains

Safety chains are a requirement and should be crossed under the tongue of the trailer so that the tongue will not drop to the road if it becomes separated from the hitch. Always leave enough slack so you can turn. Never allow the safety chains to drag on the ground and never attach the chains to the bumper.

Trailer Classification: Safety Chain Breaking Force - Minimum

Class 1: 2,000 lbs. (8.9 kN)

Class 2: 3,500 lbs. (15.6 kN)

Class 3: 5,000 lbs. (22.2 kN)

The strength rating of each length of safety chain or its equivalent and its attachments shall be equal to or exceed in minimum breaking force the GVWR (Gross Vehicle Weight Rating) of the trailer.

Electrical

Trailer lights, Electric Brakes, Break-away systems - Every time you tow, be sure to check that all components are working properly.

Wiring identification by color:

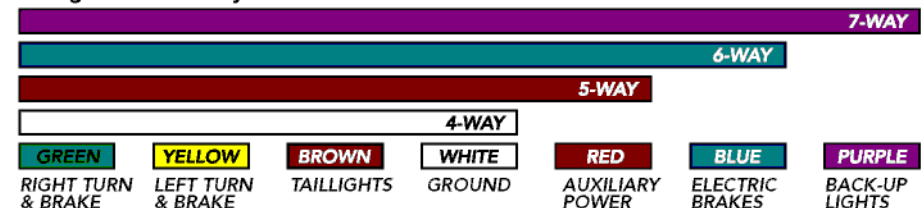

CURT DISCLAIMER: WIRING COLOR SHOWN WORK IN CONJUNCTION WITH CURT MANUFACTURING PRODUCTS.

11213

HYUNDAI ACCENT (EXCLUDES GS)

9/23/11

GROSS LOAD CAPACITY WHEN USED AS A WEIGHT CARRYING HITCH: 2,000 LBS. TRAILER WEIGHT & 200 LBS. TONGUE WEIGHT.

*****DO NOT EXCEED VEHICLE MANUFACTURER'S RECOMMENDED TOWING CAPACITY.*****

WARNING: ALL NON-TRAILER LOADS APPLIED TO THIS PRODUCT MUST BE SUPPORTED BY 18050 STABILIZING STRAPS.

**** FAILURE TO PROPERLY SUPPORT NON-TRAILER LOADS WILL VOID PRODUCT WARRANTY****

HAVING INSTALLATION QUESTIONS? CALL TECHNICAL SUPPORT AT 1-800-798-0813

| Parts List | | | |
|------------|-----|-----------------|--|
| ITEM | QTY | PART NUMBER | DESCRIPTION |
| 1 | 4 | 7/16-14 x 1 1/4 | CARRIAGE BOLT |
| 2 | 4 | 7/16-14 | HEX FLANGE NUT |
| 3 | 4 | CM-SP19 | .250 x 1.25 x 3.00" SQUARE HOLE SPACER |
| 4 | 1 | CM-SP34 | .188 x 1.50 x 3.00" ROUND HOLE SPACER |
| 5 | 1 | 3/8-16 X 1 1/2 | HEX BOLT |
| 6 | 1 | 3/8" | WASHER |
| 7 | 1 | HFN3816 | HEX FLANGE NUT |
| 8 | 2 | 7_16 FISHWIRE | 7/16" FISHWIRE |

| TOOLS REQUIRED |
|----------------|
| RATCHET |
| TORQUE WRENCH |
| 11/16" SOCKET |
| 9/16" SOCKET |

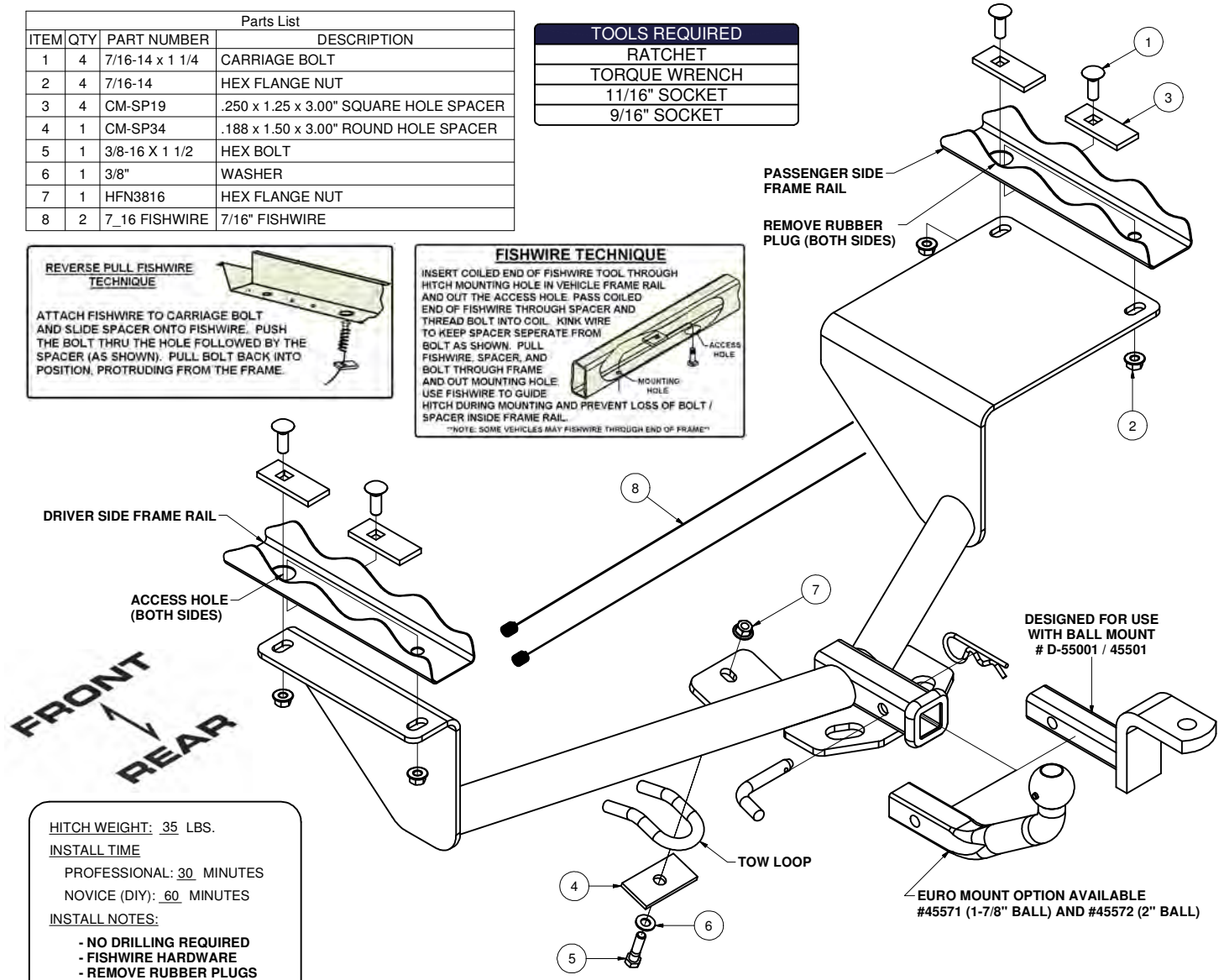
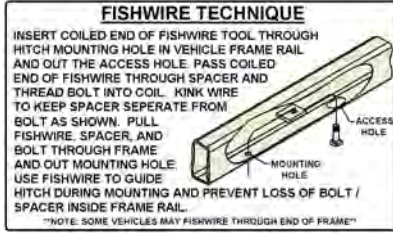
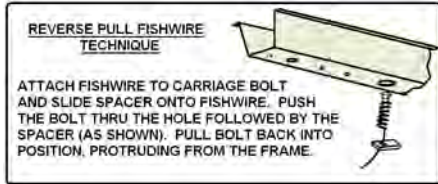

HITCH WEIGHT: 35 LBS.
 INSTALL TIME
 PROFESSIONAL: 30 MINUTES
 NOVICE (DIY): 60 MINUTES
 INSTALL NOTES:
 - NO DRILLING REQUIRED
 - FISHWIRE HARDWARE
 - REMOVE RUBBER PLUGS

INSTALLATION STEPS

1. If present, remove rubber plugs from frame holes and return to owner.
2. Fishwire (1) 7/16" carriage bolt and (1) CM-SP19 spacer through the access hole into the rearward hole on both sides. Fishwire (1) 7/16" carriage bolt and (1) CM-SP19 spacer into the access hole on each side. Refer to "Reverse Pull Fishwire Technique" as shown above.
3. Raise the hitch into position. **NOTE: The tow loop mounting tab will rest on top of the tow loop.** Be careful not to push the carriage bolts back into the frame. Loosely install (4) 7/16" hex flange nuts.
4. Install the remaining 3/8" hardware with (1) CM-SP34 spacer onto the vehicle tow loop, as shown above.
5. Torque all 3/8" fasteners to 30 lb-ft and all 7/16" fasteners to 50 lb-ft.

PERIODICALLY CHECK THIS RECEIVER HITCH TO ENSURE THAT ALL FASTENERS ARE TIGHT AND THAT ALL STRUCTURAL COMPONENTS ARE SOUND.

Curt Manufacturing LLC., warrants this product to be free of defects in material and/or workmanship at the time of retail purchase by the original purchaser. If the product is found to be defective, Curt Manufacturing LLC., may repair or replace the product, at their option, when the product is returned, prepaid, with proof of purchase. Alteration, to misuse of, or improper installation of this product voids the warranty. Curt Manufacturing LLC.'s liability is limited to repair or replacement of products found to be defective, and specifically excludes liability for incidental or consequential loss or damage.