

11218**97-01 HYUNDAI TIBURON COUPE**

12/5/2012

GROSS LOAD CAPACITY WHEN USED AS A WEIGHT CARRYING HITCH: 1,500 LBS. TRAILER WEIGHT & 150 LBS. TONGUE WEIGHT.

*****DO NOT EXCEED VEHICLE MANUFACTURER'S RECOMMENDED TOWING CAPACITY.*****

WARNING: ALL NON-TRAILER LOADS APPLIED TO THIS PRODUCT MUST BE SUPPORTED BY 18050 STABILIZING STRAPS.

**** FAILURE TO PROPERLY SUPPORT NON-TRAILER LOADS WILL VOID PRODUCT WARRANTY****

HAVING INSTALLATION QUESTIONS? CALL TECHNICAL SUPPORT AT 1-800-798-0813

Parts List			
ITEM	QTY	PART NUMBER	DESCRIPTION
1	2	7/16-14 x 1 1/2	HEX BOLT
2	4	7/16-14 x 1 1/4	HEX BOLT
3	6	7/16 WASHER	WASHER
4	6	7/16 LOCK WASHER	HELICAL LOCK WASHER
5	6	7/16-14	HEX NUT
6	1	CM-11218-BP	2.000 x .250" BACKING PLATE

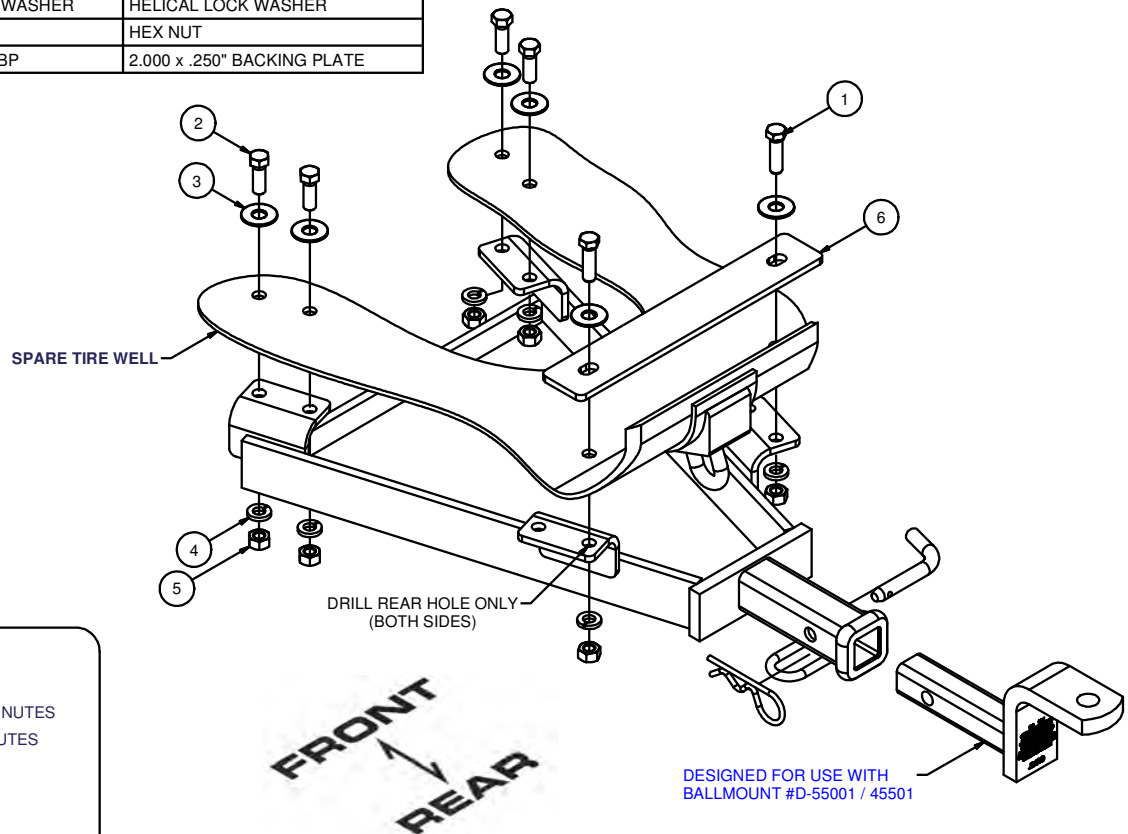

HITCH WEIGHT: 14 LBS.

INSTALL TIME

PROFESSIONAL: 20 MINUTES

NOVICE (DIY): 40 MINUTES

INSTALL NOTES:

- DRILLING REQUIRED
- REMOVE SPARE TIRE
- SILICONE SEAL TRUNK

INSTALLATION STEPS

1. This hitch mounts to the spare tire well, around the tow loop. Temporarily remove contents of trunk area.
2. Position hitch on the bottom of the spare tire well, centered left to right and fully forward against the tow loop.
3. Using hitch as a drill template, drill holes for fasteners. Note: Drill only the two rear most holes in rear angle brackets, as shown.
4. With the hitch in position, install fasteners. Install backing plate inside trunk area against the bottom surface of spare tire well, as shown.
5. Torque all 7/16" fasteners to 70 ft-lbs.
6. Use silicone sealant to seal hardware installed through spare tire well.
7. Replace spare tire removed in Step 1.

PERIODICALLY CHECK THIS RECEIVER HITCH TO ENSURE THAT ALL FASTENERS ARE TIGHT AND THAT ALL STRUCTURAL COMPONENTS ARE SOUND.

Curt Manufacturing Inc., warrants this product to be free of defects in material and/or workmanship at the time of retail purchase by the original purchaser. If the product is found to be defective, Curt Manufacturing Inc., may repair or replace the product, at their option, when the product is returned, prepaid, with proof of purchase. Alteration to, misuse of, or improper installation of this product voids the warranty. Curt Manufacturing Inc.'s liability is limited to repair or replacement of products found to be defective, and specifically excludes liability for incidental or consequential loss or damage.