

11235**91-94 MAZDA PROTEGE**

12/5/2012

GROSS LOAD CAPACITY WHEN USED AS A WEIGHT CARRYING HITCH: 2,000 LBS. TRAILER WEIGHT & 200 LBS. TONGUE WEIGHT.

*****DO NOT EXCEED VEHICLE MANUFACTURER'S RECOMMENDED TOWING CAPACITY.*******WARNING: ALL NON-TRAILER LOADS APPLIED TO THIS PRODUCT MUST BE SUPPORTED BY 18050 STABILIZING STRAPS.****** FAILURE TO PROPERLY SUPPORT NON-TRAILER LOADS WILL VOID PRODUCT WARRANTY****

HAVING INSTALLATION QUESTIONS? CALL TECHNICAL SUPPORT AT 1-800-798-0813

Parts List			
ITEM	QTY	PART NUMBER	DESCRIPTION
1	2	5_8 - 11 x 2 HEX	HEX BOLT
2	2	5/8	WASHER
3	2	5/8-11	HEX FLANGE NUT
4	2	CM-SP51	.250 x 1.50 x 3.50" ROUND HOLE SPACER
5	2	7_16 - 14 x 4 1_2 HEX	HEX BOLT
6	2	7/16-14	HEX FLANGE NUT

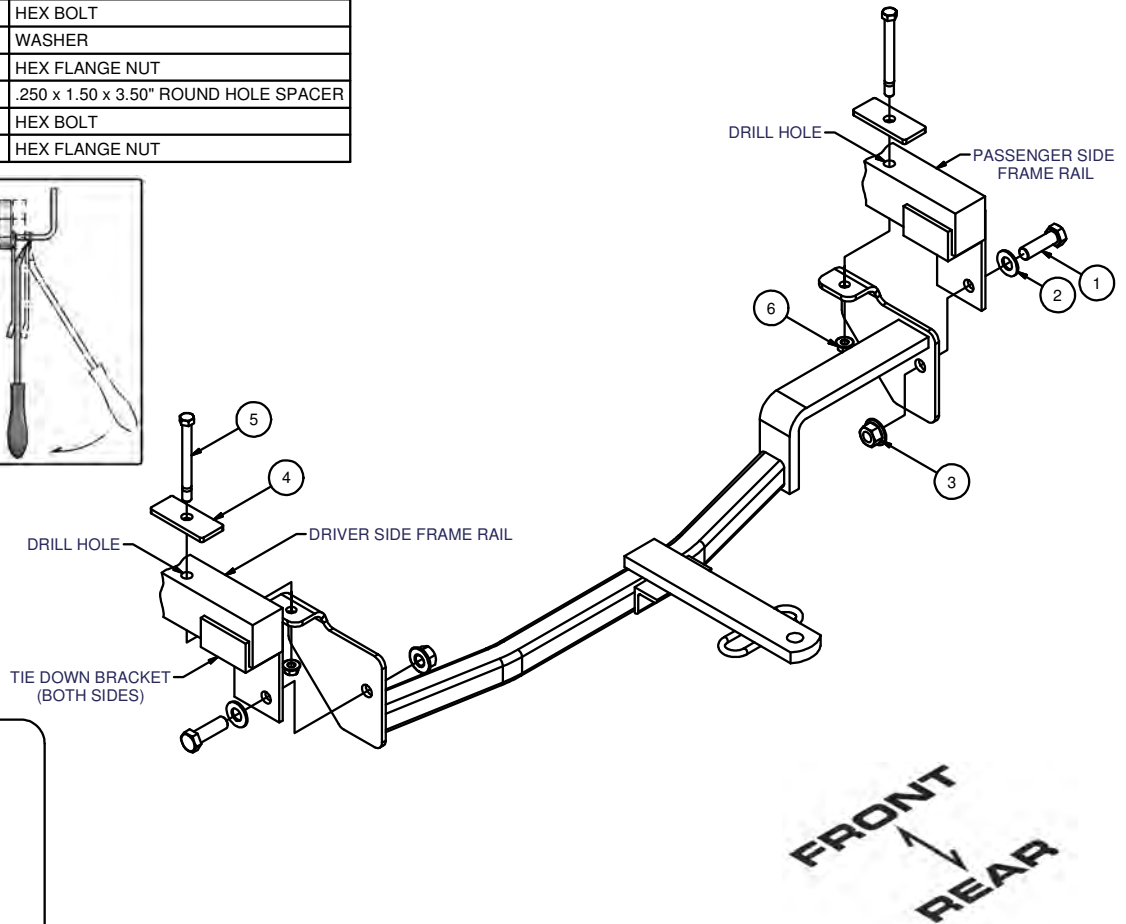
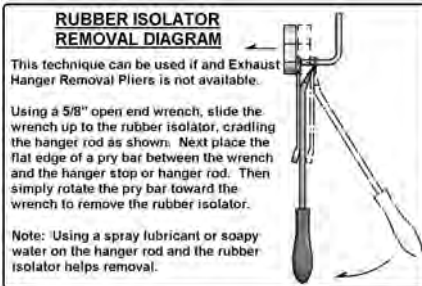

HITCH WEIGHT: 22 LBS.

INSTALL TIME

PROFESSIONAL: 20 MINUTES

NOVICE (DIY): 40 MINUTES

INSTALL NOTES:

- LOWER EXHAUST
- CLEAR TRUNK
- DRILLING REQUIRED
- SILICONE SEAL HARDWARE

INSTALLATION STEPS

1. Work hitch into position over exhaust extension and between tie down brackets as shown. It may be easier to temporarily release rear exhaust hangers. Tabs on hitch end brackets should fit against frame bottom surface. Adjust hitch for best fit and then install fasteners into tie down brackets.
2. Clear interior of trunk before drilling. Drill holes through holes in tabs straight up through lower and upper surface of frame rails. Some vehicles have angled baffle plate inside frame rails and it will be necessary to drill through this surface also.
3. Install fasteners as shown. Tighten fasteners only until sheet metal begins to compress. Do not use an air wrench.
4. Torque all 7/16" hardware to 70 lb.-ft. and all 5/8" hardware to 210 lb.-ft.
5. Silicone seal hardware installed through trunk floor.
6. Raise exhaust back into position and reinstall contents removed from trunk.

PERIODICALLY CHECK THIS RECEIVER HITCH TO ENSURE THAT ALL FASTENERS ARE TIGHT AND THAT ALL STRUCTURAL COMPONENTS ARE SOUND.

Curt Manufacturing Inc., warrants this product to be free of defects in material and/or workmanship at the time of retail purchase by the original purchaser. If the product is found to be defective, Curt Manufacturing Inc., may repair or replace the product, at their option, when the product is returned, prepaid, with proof of purchase. Alteration to, misuse of, or improper installation of this product voids the warranty. Curt Manufacturing Inc.'s liability is limited to repair or replacement of products found to be defective, and specifically excludes liability for incidental or consequential loss or damage.