

**11253****89-94 NISSAN MAXIMA**

11/13/2017

**GROSS LOAD CAPACITY WHEN USED AS A WEIGHT CARRYING HITCH: 2,000 LBS. TRAILER WEIGHT & 200 LBS. TONGUE WEIGHT.**

\*\*\*DO NOT EXCEED VEHICLE MANUFACTURER'S RECOMMENDED TOWING CAPACITY.\*\*\*

**WARNING: ALL NON-TRAILER LOADS APPLIED TO THIS PRODUCT MUST BE SUPPORTED BY AUXILIARY STABILIZING STRAPS.**

\*\* FAILURE TO PROPERLY SUPPORT NON-TRAILER LOADS WILL VOID PRODUCT WARRANTY\*\*

**HAVING INSTALLATION QUESTIONS? CALL TECHNICAL SUPPORT AT 1-800-798-0813**

| Parts List |     |                 |  |
|------------|-----|-----------------|--|
| ITEM       | QTY | PART NUMBER     | DESCRIPTION                            |
| 1          | 1   | CM-438-FW       | 7/16 " FISHWIRE TOOL                   |
| 2          | 2   | 7/16-14         | HEX FLANGE NUT                         |
| 3          | 4   | M10 - 1.25 x 30 | HEX BOLT                               |
| 4          | 2   | CM-SP40         | .188 x 1.00 x 3.00" SQUARE HOLE SPACER |
| 5          | 2   | 7/16-14 x 1 1/2 | CARRIAGE BOLT                          |
| 6          | 4   | 3/8"            | CONICAL TOOTHED WASHER                 |

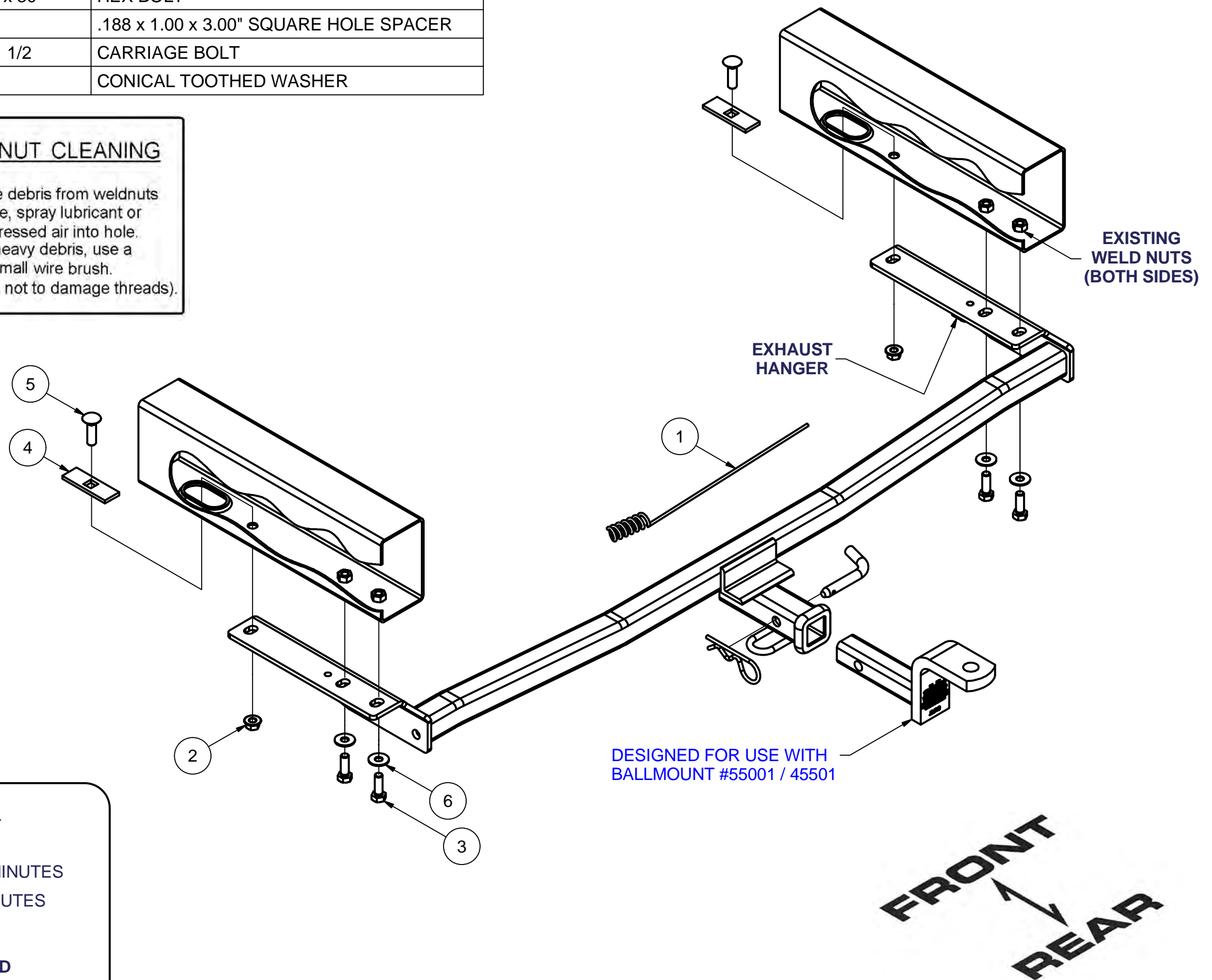
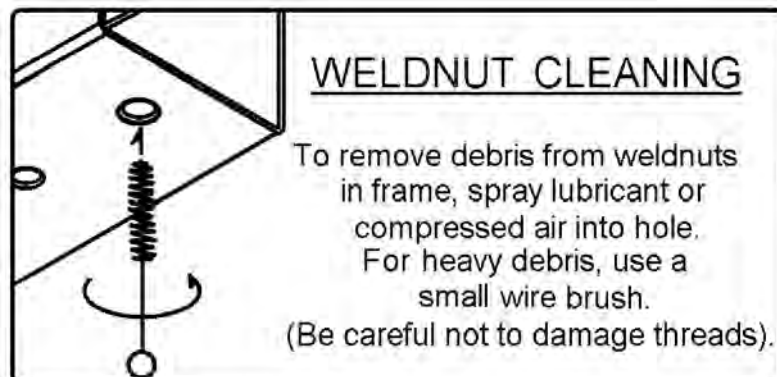

HITCH WEIGHT: 25 LBS.

**INSTALL TIME**

PROFESSIONAL: 30 MINUTES

NOVICE (DIY): 60 MINUTES

**INSTALL NOTES:****- NO DRILLING REQUIRED****INSTALLATION STEPS**

1. Remove tie down brackets from both frame rails under the car. From the passenger side also remove the exhaust hanger bracket.
2. Lifting hitch into position, mount hitch to the car with the M10 bolts provided.
3. Using the fishwire tool, place the spacer and the 7/16" carriage bolts, into position inside the frame and through the hole as shown. Redrilling this hole for alignment may be necessary before fishwiring the fasteners.
4. Reattach exhaust reusing the cars hangers and the hanger rod provided on the hitch.
5. Tighten all 7/16" hardware to 70 lb-ft and all M10 hardware to 48 lb-ft.

PERIODICALLY CHECK THIS RECEIVER HITCH TO ENSURE THAT ALL FASTENERS ARE TIGHT AND THAT ALL STRUCTURAL COMPONENTS ARE SOUND.

Curt Manufacturing Inc., warrants this product to be free of defects in material and/or workmanship at the time of retail purchase by the original purchaser. If the product is found to be defective, Curt Manufacturing Inc., may repair or replace the product, at their option, when the product is returned, prepaid, with proof of purchase. Alteration to, misuse of, or improper installation of this product voids the warranty. Curt Manufacturing Inc.'s liability is limited to repair or replacement of products found to be defective, and specifically excludes liability for incidental or consequential loss or damage.