

11266

TOYOTA COROLLA (INCLUDING "S")

7/16/2012

GROSS LOAD CAPACITY WHEN USED AS A WEIGHT CARRYING HITCH: 2,000 LBS. TRAILER WEIGHT & 200 LBS. TONGUE WEIGHT.

DO NOT EXCEED VEHICLE MANUFACTURER'S RECOMMENDED TOWING CAPACITY.

WARNING: ALL NON-TRAILER LOADS APPLIED TO THIS PRODUCT MUST BE SUPPORTED BY AUXILIARY STABILIZING STRAPS.

** FAILURE TO PROPERLY SUPPORT NON-TRAILER LOADS WILL VOID PRODUCT WARRANTY**

HAVING INSTALLATION QUESTIONS? CALL TECHNICAL SUPPORT AT 1-800-798-0813

Parts List			
ITEM	QTY	PART NUMBER	DESCRIPTION
1	4	M12-1.25 x 30mm	HEX BOLT
2	4	1/2"	CONICAL TOOTHED WASHER

TOOLS REQUIRED	
19mm	SOCKET
10"	EXTENSION
	RATCHET
	TORQUE WRENCH

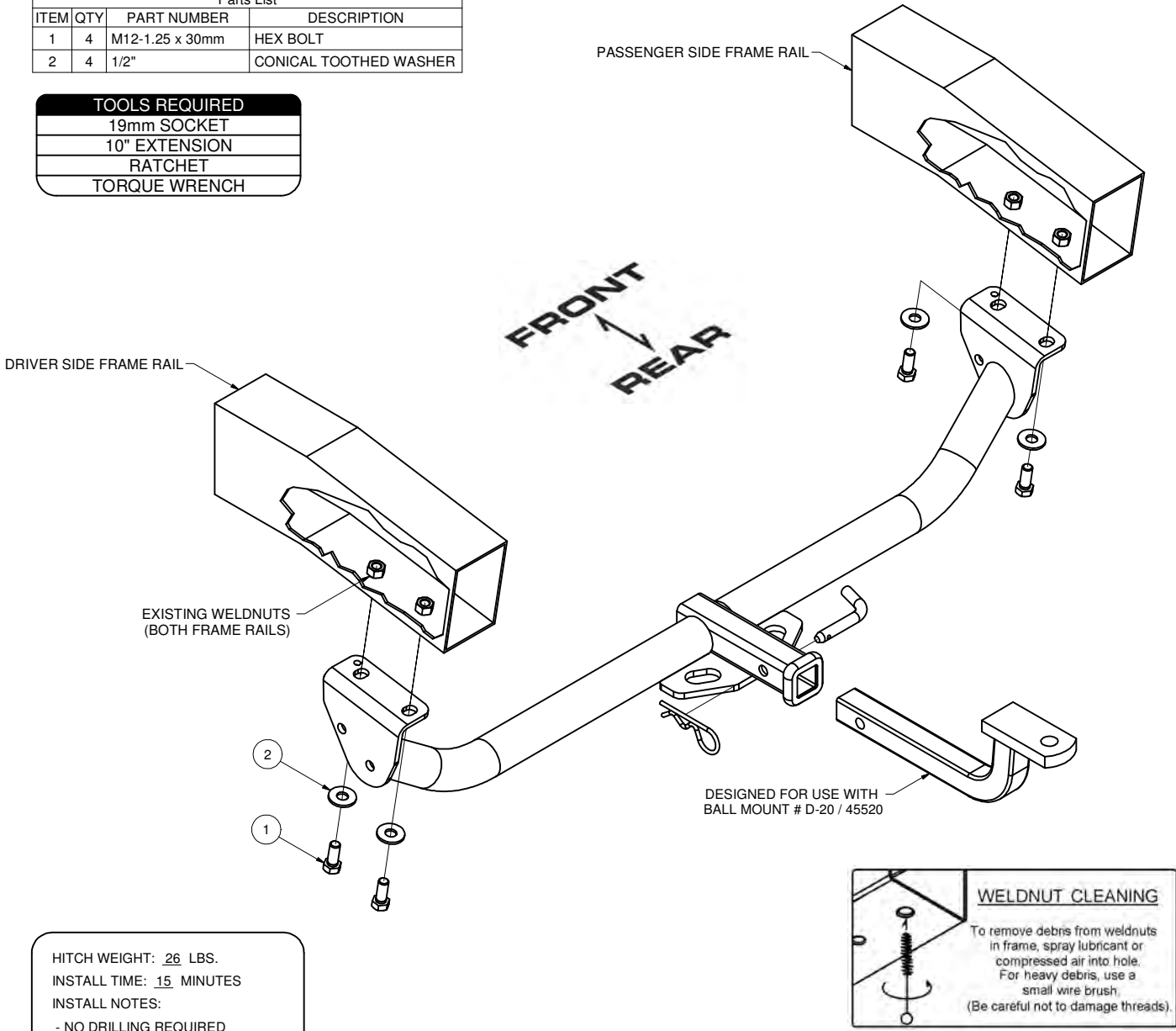

HITCH WEIGHT: 26 LBS.
 INSTALL TIME: 15 MINUTES
 INSTALL NOTES:
 - NO DRILLING REQUIRED

INSTALLATION STEPS

1. Remove the tow hooks (if equipped), return to customer.
2. Raise hitch into position, aligning the slots in the side plates with existing weldnuts in the frame rails.
3. Install hex bolts and conical toothed washers as shown.
4. Torque 12mm hardware to 86 ft-lbs.

PERIODICALLY CHECK THIS RECEIVER HITCH TO ENSURE THAT ALL FASTENERS ARE TIGHT AND THAT ALL STRUCTURAL COMPONENTS ARE SOUND.

Curt Manufacturing Inc., warrants this product to be free of defects in material and/or workmanship at the time of retail purchase by the original purchaser. If the product is found to be defective, Curt Manufacturing Inc., may repair or replace the product, at their option, when the product is returned, prepaid, with proof of purchase. Alteration to, misuse of, or improper installation of this product voids the warranty. Curt Manufacturing Inc.'s liability is limited to repair or replacement of products found to be defective, and specifically excludes liability for incidental or consequential loss or damage.