



Safety glasses should be worn at all times while installing this product.

YEARS: 2012-CURRENT

MAKE: SUBARU

MODEL: IMPREZA & (XV) CROSSTREK

STYLE: 5-DOOR

WARNING: NEVER EXCEED YOUR VEHICLE MANUFACTURER'S RECOMMENDED TOWING CAPACITY

WEIGHT CARRYING:
 TRAILER WEIGHT: 2,000 LBS.
 TONGUE WEIGHT: 200 LBS.

WARNING:
 WE RECOMMEND THE USE OF 18050 STABILIZING STRAPS FOR ALL NON-TRAILER (WHEEL-LESS) LOADS. PLEASE SEE THE CURT CATALOG OR VISIT US ONLINE AT WWW.CURTMFG.COM FOR FURTHER INFORMATION.

INSTALLATION TIME: 30 MIN.

THE INSTALL TIME LISTED IS FOR PROFESSIONAL INSTALLERS. IF YOU ARE HESITANT TO UNDERTAKE THIS TASK ON YOUR OWN, CONTACT AN AUTHORIZED CURT INSTALLER FOR ADDITIONAL ASSISTANCE.

INSTALLATION REQUIRES:

DIE GRINDER	11/16\" 3/4\" SOCKET	RATCHET
SAFETY GLASSES	TORQUE WRENCH	

INSTALLATION TIPS:

- BEFORE YOU BEGIN INSTALLATION, READ ALL INSTRUCTIONS THOROUGHLY.
- TO EASE INSTALLATION, 2 PEOPLE MAY BE REQUIRED.
- USING PROPER TOOLS WILL GREATLY IMPROVE THE QUALITY OF THE INSTALL AND REDUCE THE TIME REQUIRED.
- NEED HELP OR HAVE SOME QUESTIONS? CALL TECHNICAL SUPPORT AT 800.798.0813

LEVEL OF DIFFICULTY: EASY

EASY	MODERATE	CHALLENGING
		FISHWIRE (2) FASTENERS
		ENLARGE ACCESS HOLES FOR SPACERS AND BOLTS
		REMOVE (4) RUBBER PLUGS
		REVERSE FISHWIRE (2) FASTENERS

VEHICLE PHOTO:



REPRESENTATIVE PHOTO

HITCH ILLUSTRATION:

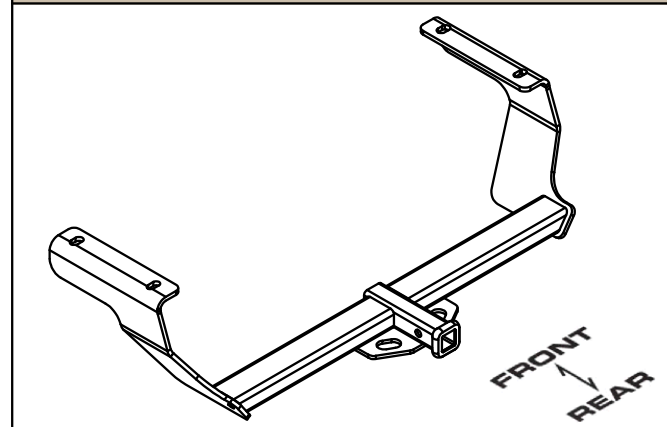

MAKE SURE YOUR HITCH MATCHES

PERIODICALLY CHECK THIS RECEIVER HITCH TO ENSURE ALL FASTENERS ARE TIGHT AND ALL STRUCTURAL COMPONENTS ARE SOUND

CURT Manufacturing LLC. warrants this product to be free of defects in material and/or workmanship at the time of retail purchase by the original purchaser. If the product is found to be defective, Curt Manufacturing LLC. may repair or replace the product at their option, when the product is returned, prepaid, with proof of purchase. Alteration to, misuse of, or improper installation of this product voids the warranty. Curt Manufacturing LLC.'s liability is limited to repair or replacement of products found to be defective, and specifically excludes liability for incidental or consequential loss or damage.

For more information log onto www.curtmfg.com, & for helpful towing tips log onto www.hitchinfo.com

INSTALLATION WALKTHROUGH:

Parts List			
ITEM	QTY	PART NUMBER	DESCRIPTION
1	2	1/2-13 x 1 1/2	CARRIAGE BOLT
2	2	CM-SP6	.250 x 1.00 x 3.00" SQUARE HOLE SPACER
3	2	7/16-14 x 1 1/2	CARRIAGE BOLT
4	2	CM-SP11	.250 x 1.00 x 2.50" SQUARE HOLE SPACER
5	2	CM-SP16	.250 x 1.50 x 2.00" ROUND HOLE SPACER
6	2	HFN 1213	HEX FLANGE NUT
7	2	7/16-14	HEX FLANGE NUT
8	1	7_16 FISHWIRE	7/16" FISHWIRE
9	1	1_2 FISHWIRE	1/2" FISHWIRE

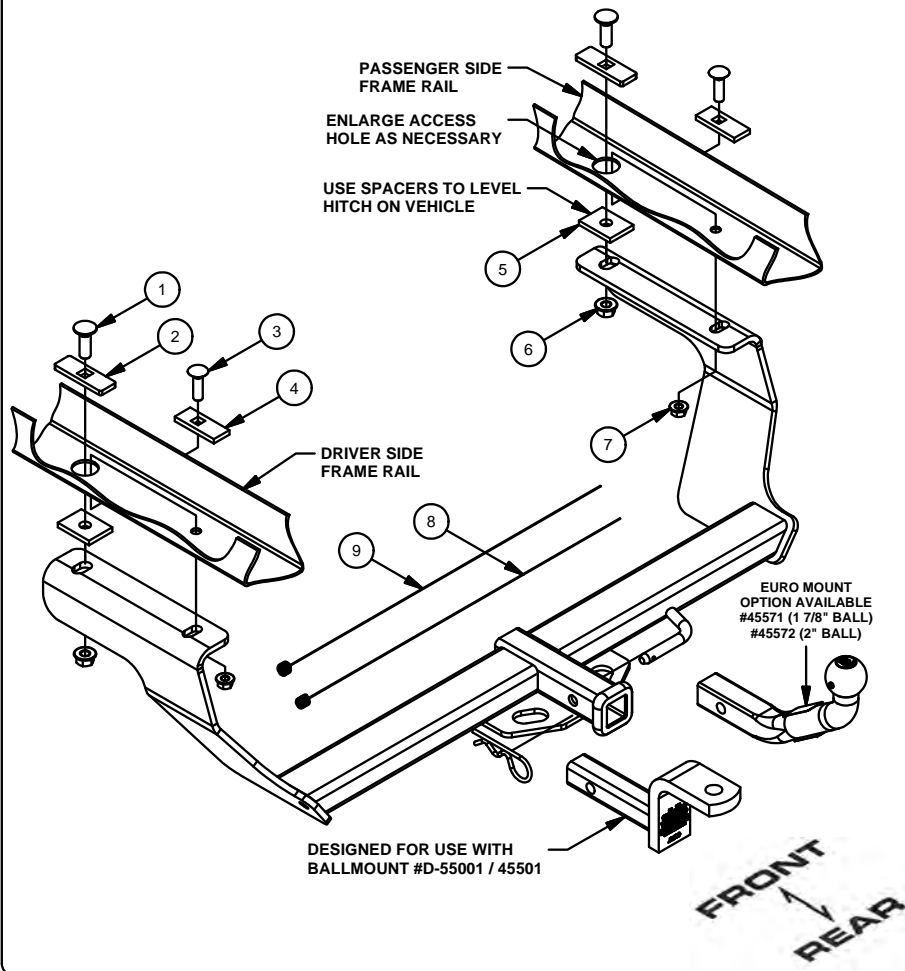

1) Remove the (4) plugs in the frame rails and discard (leave center plugs in).

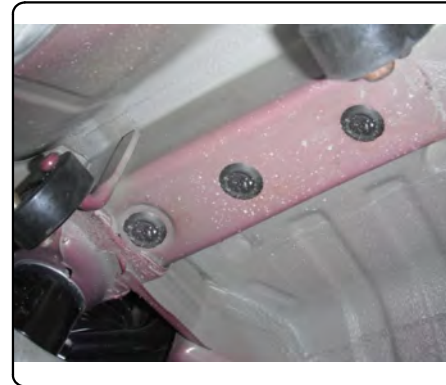

2) Fishwire 7/16" carriage bolts and spacers into position first and reverse fishwire the 1/2" carriage bolts and spacers into position afterward. (enlarge access hole as necessary)

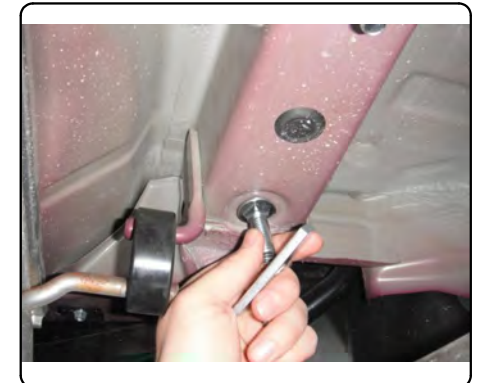
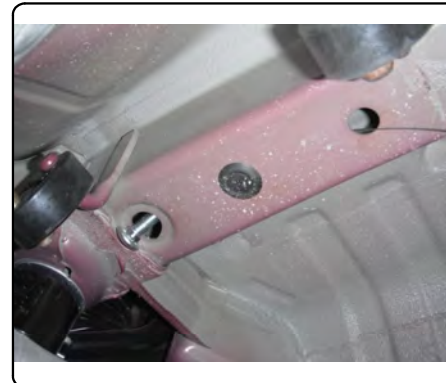

INSTALLATION WALKTHROUGH:

- 3) Raise hitch to the frame aligning the holes in the hitch with the bolts. Use 1.50" x 2.00" spacers to level hitch as necessary.

NOTE:
Be careful not to push the bolts in the frame.



- 4) Install remaining supplied hardware, as shown on page 2.

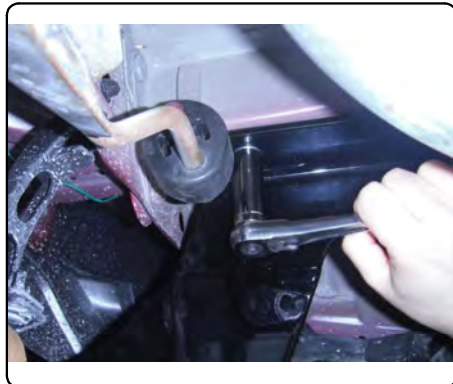
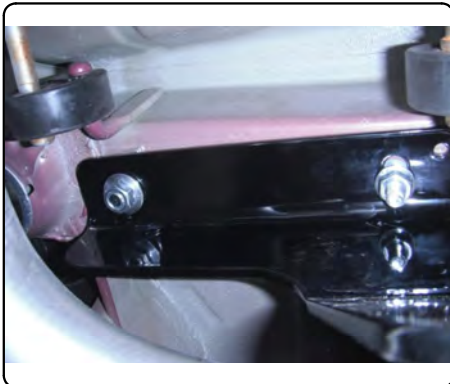

- 5) Torque all 7/16" fasteners to 70 lb-ft, and all 1/2" fasteners to 110 lb-ft.

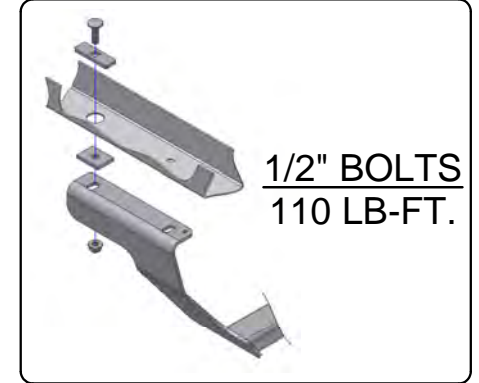
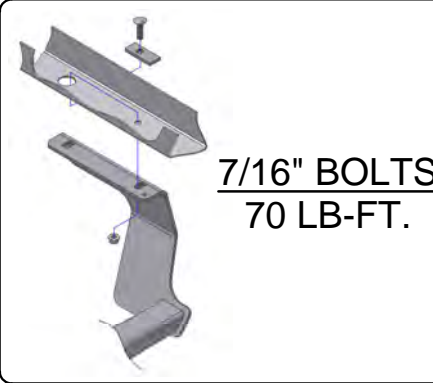

INSTALLATION COMPLETE



11286

SUBARU IMPREZA 5-DOOR & (XV) CROSSTREK

7/18/2016

SINGLE EXHAUST

GROSS LOAD CAPACITY WHEN USED AS A WEIGHT CARRYING HITCH: 2,000 LBS. TRAILER WEIGHT & 200 LBS. TONGUE WEIGHT.
 DO NOT EXCEED VEHICLE MANUFACTURER'S RECOMMENDED TOWING CAPACITY.

Parts List			
ITEM	QTY	PART NUMBER	DESCRIPTION
1	2	1/2-13 x 1 1/2	CARRIAGE BOLT
2	2	CM-SP6	.250 x 1.00 x 3.00" SQUARE HOLE SPACER
3	2	7/16-14 x 1 1/2	CARRIAGE BOLT
4	2	CM-SP11	.250 x 1.00 x 2.50" SQUARE HOLE SPACER
5	2	CM-SP16	.250 x 1.50 x 2.00" ROUND HOLE SPACER
6	2	HFN 1213	HEX FLANGE NUT
7	2	7/16-14	HEX FLANGE NUT
8	1	7_16 FISHWIRE	7/16" FISHWIRE
9	1	1_2 FISHWIRE	1/2" FISHWIRE

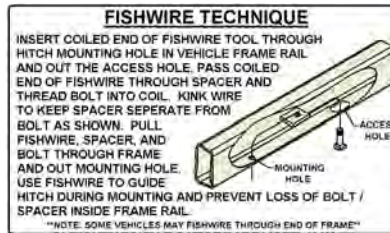

TOOLS REQUIRED

3/8" DRIVE RATCHET
11/16" - 3/8" DRIVE SOCKET
3/4" - 3/8" DRIVE SOCKET
DIE GRINDER W/ RASP BIT
3/8" DRIVE TORQUE WRENCH

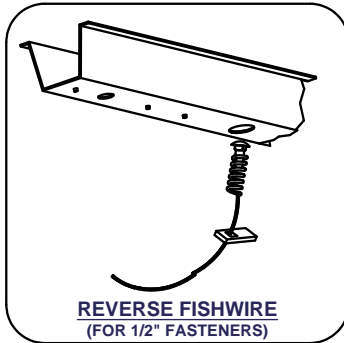

HITCH WEIGHT: 30 LBS.
 INSTALL TIME: 30 MINUTES
 INSTALL NOTES:
 - HOLE ENLARGEMENT REQUIRED

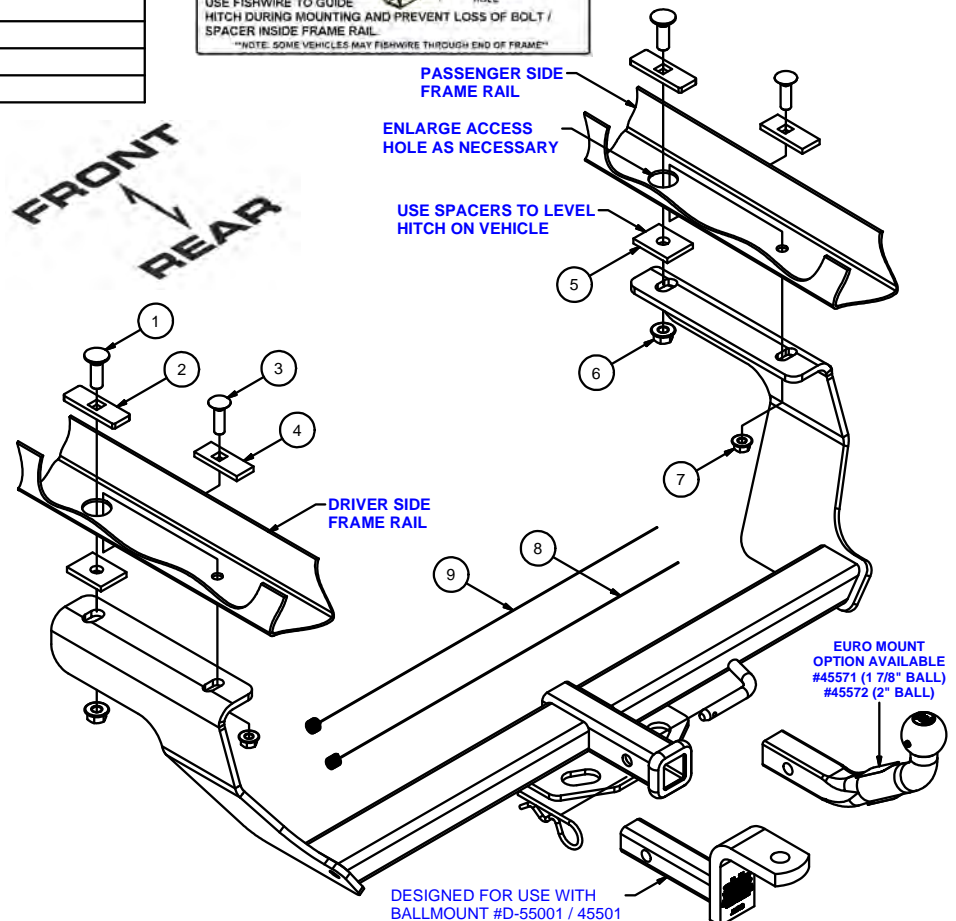

INSTALLATION STEPS

- 1) Remove the (4) plugs in the frame rails and discard (leave center plugs in).
- 2) Fishwire 7/16" carriage bolts and spacers into position first and reverse fishwire the 1/2" carriage bolts and spacers into position afterward. (enlarge access hole as necessary)
- 3) Raise hitch to the frame aligning the holes in the hitch with the bolts. Use 1.50" x 2.00" spacers to level hitch as necessary.

NOTE: Be careful not to push the bolts in the frame.

- 4) Install remaining supplied hardware, as shown above.
- 5) Torque all 7/16" fasteners to 70 lb-ft, and all 1/2" fasteners to 110 lb-ft.

PERIODICALLY CHECK THIS RECEIVER HITCH TO ENSURE THAT ALL FASTENERS ARE TIGHT AND THAT ALL STRUCTURAL COMPONENTS ARE SOUND.

Curt Manufacturing Inc., warrants this product to be free of defects in material and/or workmanship at the time of retail purchase by the original purchaser. If the product is found to be defective, Curt Manufacturing Inc., may repair or replace the product, at their option, when the product is returned, prepaid, with proof of purchase. Alteration to, misuse of, or improper installation of this product voids the warranty. Curt Manufacturing Inc.'s liability is limited to repair or replacement of products found to be defective, and specifically excludes liability for incidental or consequential loss or damage.