



Safety glasses should be worn at all times while installing this product.

YEARS: 2013-PRESENT

MAKE: CHEVROLET

MODEL: MALIBU ECO

STYLE: SEDAN

WARNING: NEVER EXCEED YOUR VEHICLE MANUFACTURER'S RECOMMENDED TOWING CAPACITY





WEIGHT CARRYING:
 TRAILER WEIGHT: 2000 LBS.
 TONGUE WEIGHT: 200 LBS.

WARNING:
 WE RECOMMEND THE USE OF 18050 STABILIZING STRAPS FOR ALL NON-TRAILER (WHEEL-LESS) LOADS. PLEASE SEE THE CURT CATALOG OR VISIT US ONLINE AT WWW.CURTMFG.COM FOR FURTHER INFORMATION.

INSTALLATION TIME: 40 MIN.

THE INSTALL TIME LISTED IS FOR PROFESSIONAL INSTALLERS. IF YOU ARE HESITANT TO UNDERTAKE THIS TASK ON YOUR OWN, CONTACT AN AUTHORIZED CURT INSTALLER FOR ADDITIONAL ASSISTANCE.



INSTALLATION REQUIRES:

 BOXED END WRENCH 15mm	 RATCHET	 SAFETY GLASSES
 13mm 15mm 3/4" SOCKET	 TORQUE WRENCH	

INSTALLATION TIPS:

- BEFORE YOU BEGIN INSTALLATION, READ ALL INSTRUCTIONS THOROUGHLY.
- TO EASE INSTALLATION, 2 PEOPLE MAY BE REQUIRED.
- USING PROPER TOOLS WILL GREATLY IMPROVE THE QUALITY OF THE INSTALL AND REDUCE THE TIME REQUIRED.
- NEED HELP OR HAVE SOME QUESTIONS? CALL TECHNICAL SUPPORT AT 800.798.0813

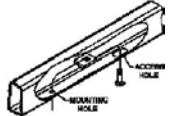
LEVEL OF DIFFICULTY: MODERATE

EASY	MODERATE	CHALLENGING
	FISHWIRE HARDWARE	
	LOWER EXHAUST	
	NO DRILLING REQUIRED	

VEHICLE PHOTO:



REPRESENTATIVE PHOTO

HITCH ILLUSTRATION:

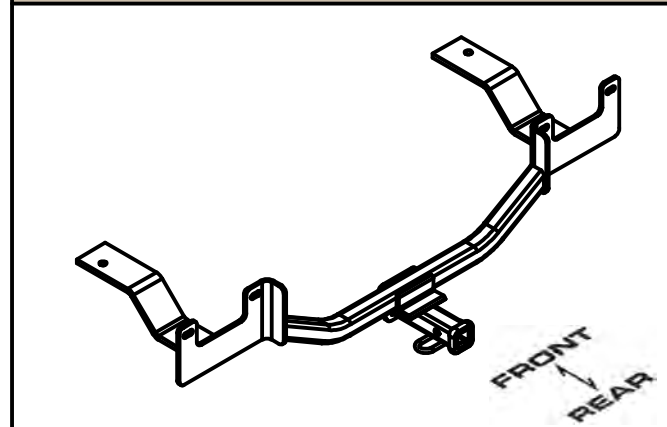

MAKE SURE YOUR HITCH MATCHES

PERIODICALLY CHECK THIS RECEIVER HITCH TO ENSURE ALL FASTENERS ARE TIGHT AND ALL STRUCTURAL COMPONENTS ARE SOUND

CURT Manufacturing LLC. warrants this product to be free of defects in material and/or workmanship at the time of retail purchase by the original purchaser. If the product is found to be defective, Curt Manufacturing LLC. may repair or replace the product at their option, when the product is returned, prepaid, with proof of purchase. Alteration to, misuse of, or improper installation of this product voids the warranty. Curt Manufacturing LLC.'s liability is limited to repair or replacement of products found to be defective, and specifically excludes liability for incidental or consequential loss or damage.

For more information log onto www.curtmfg.com, & for helpful towing tips log onto www.hitchinfo.com

INSTALLATION WALKTHROUGH:

Parts List			
ITEM	QTY	PART NUMBER	DESCRIPTION
1	2	1/2-13 x 1 3/4	CARRIAGE BOLT
2	2	CM-SP6	.250" SQUARE HOLE SPACER
3	2	HFN 1213	HEX FLANGE NUT
4	2	1_2 FISHWIRE	1/2" FISHWIRE

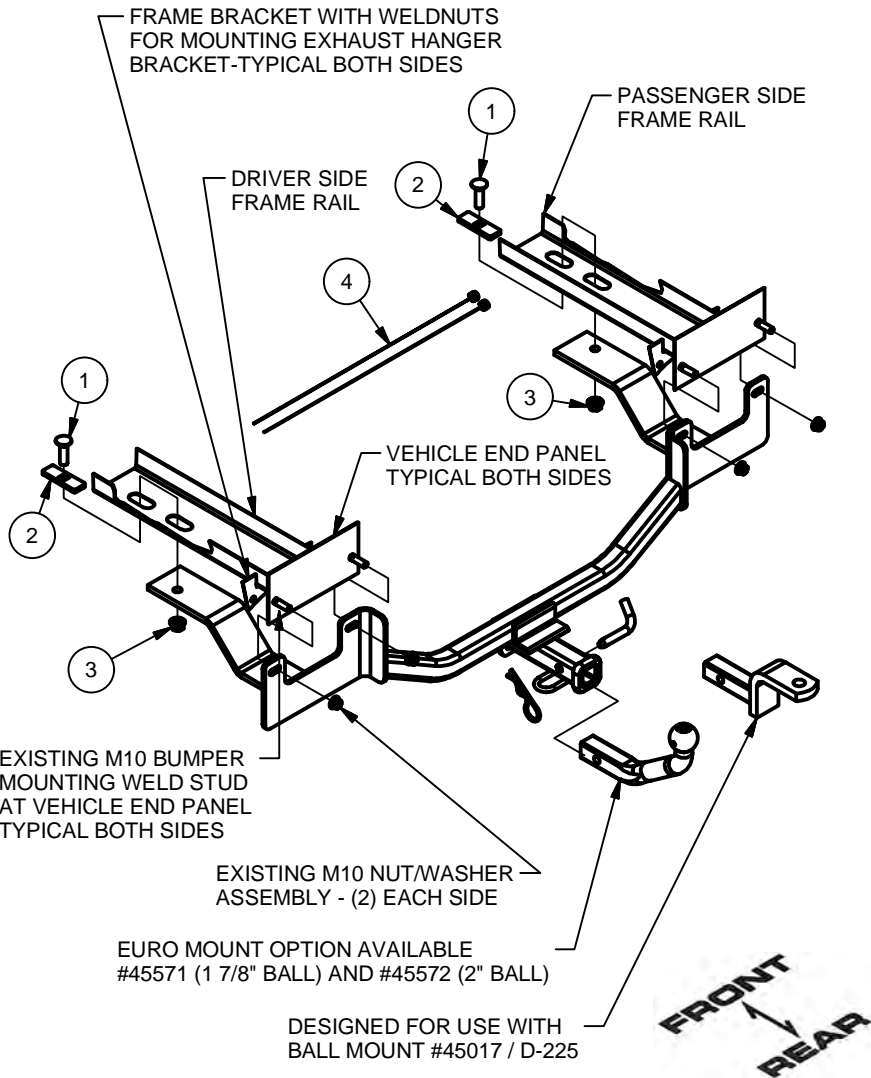

1. Lower exhaust by removing 2 bolts which attach exhaust hanger bracket to frame bracket.



2. Remove (2) bumper mounting nut/washer assemblies from each side, one on each side of frame rail.



INSTALLATION WALKTHROUGH:

3. If present, cut off stud from passenger side frame rail.



4. Fishwire carriage bolt and block up through forward slot and down through attaching slot as shown.



5. Raise hitch into position such that side arm feeds between tailpipe and exhaust hanger bracket. Raise exhaust and hitch together. Position slots in hitch side plates over bumper mounting studs and allow carriage bolts installed in step 3 to feed through holes in hitch side arms. Attach M10 nut/washer assemblies removed in step 2.

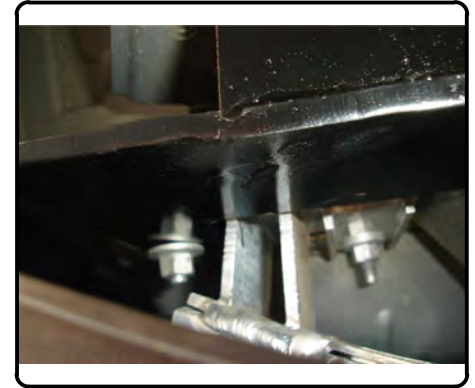

6. Attach 1/2-13 flanged hex nuts to carriage bolts at hitch side arms. Torque all M10 fasteners to 50 ft-lbs. Torque all 1/2" fasteners to 75 ft-lbs.

7. Reattach exhaust hanger bracket by reinstalling bolts.
Installation is complete



11288**2013-PRESENT CHEVROLET MALIBU ECO****5-3-12****GROSS LOAD CAPACITY WHEN USED AS A WEIGHT CARRYING HITCH: 2,000 LBS. TRAILER WEIGHT & 200 LBS. TONGUE WEIGHT.*******DO NOT EXCEED VEHICLE MANUFACTURER'S RECOMMENDED TOWING CAPACITY.*******WARNING: ALL NON-TRAILER LOADS APPLIED TO THIS PRODUCT MUST BE SUPPORTED BY 18050 STABILIZING STRAPS.****** FAILURE TO PROPERLY SUPPORT NON-TRAILER LOADS WILL VOID PRODUCT WARRANTY******HAVING INSTALLATION QUESTIONS? CALL TECHNICAL SUPPORT AT 1-800-798-0813**

Parts List			
ITEM	QTY	PART NUMBER	DESCRIPTION
1	2	1/2-13 x 1 3/4	CARRIAGE BOLT
2	2	CM-SP6	.250" SQUARE HOLE SPACER
3	2	HFN 1213	HEX FLANGE NUT
4	2	1_2 FISHWIRE	1/2" FISHWIRE

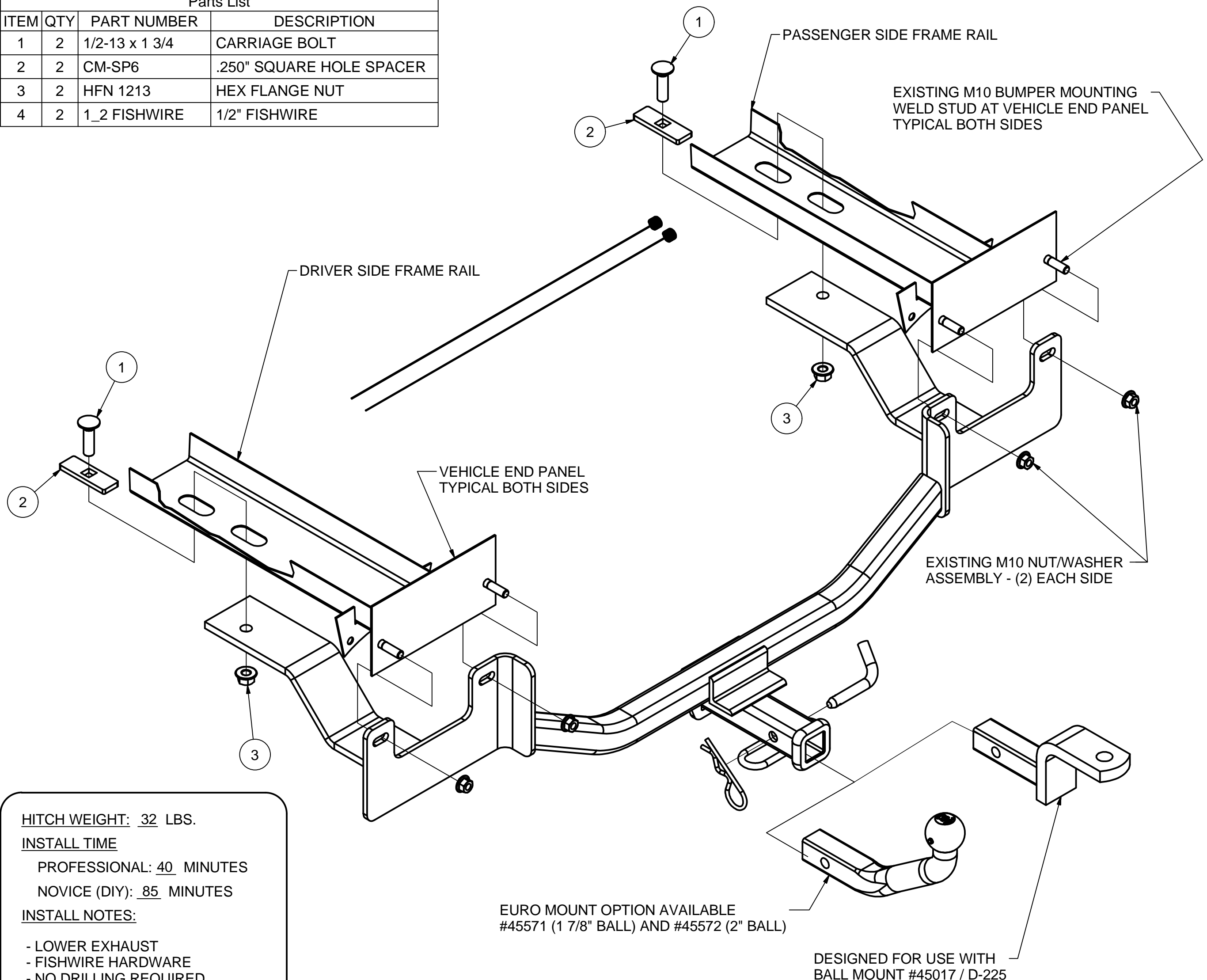
**HITCH WEIGHT: 32 LBS.****INSTALL TIME**PROFESSIONAL: 40 MINUTESNOVICE (DIY): 85 MINUTES**INSTALL NOTES:**

- LOWER EXHAUST
- FISHWIRE HARDWARE
- NO DRILLING REQUIRED

EURO MOUNT OPTION AVAILABLE
#45571 (1 7/8" BALL) AND #45572 (2" BALL)DESIGNED FOR USE WITH
BALL MOUNT #45017 / D-225**INSTALLATION STEPS**

1. Lower exhaust by removing 2 bolts which attach exhaust hanger bracket to frame bracket.
2. Remove (2) bumper mounting nut/washer assemblies from each side, one on each side of frame rail.
3. If present, cut off stud from passenger side frame rail.
4. Fishwire carriage bolt and block up through forward slot and down through attaching slot as shown.
5. Raise hitch into position such that side arm feeds between tailpipe and exhaust hanger bracket. Raise exhaust and hitch together. Position slots in hitch side plates over bumper mounting studs and allow carriage bolts installed in step 3 to feed through holes in hitch side arms. Attach M10 nut/washer assemblies removed in step 2.
6. Attach 1/2-13 flanged hex nuts to carriage bolts at hitch side arms. Torque all M10 fasteners to 50 ft-lbs. Torque all 1/2" fasteners to 75 ft-lbs.
7. Reattach exhaust hanger bracket by reinstalling bolts.

**PERIODICALLY CHECK THIS RECEIVER HITCH TO ENSURE THAT ALL FASTENERS
ARE TIGHT AND THAT ALL STRUCTURAL COMPONENTS ARE SOUND.**

Curt Manufacturing LLC., warrants this product to be free of defects in material and/or workmanship at the time of retail purchase by the original purchaser. If the product is found to be defective, Curt Manufacturing LLC., may repair or replace the product, at their option, when the product is returned, prepaid, with proof of purchase. Alteration to, misuse of, or improper installation of this product voids the warranty. Curt Manufacturing LLC.'s liability is limited to repair or replacement of products found to be defective, and specifically excludes liability for incidental or consequential loss or damage.