

**YEARS:** 2012-PRESENT

**MAKE:** TOYOTA

**MODEL:** PRIUS c

**STYLE:** HATCHBACK

**WARNING: NEVER EXCEED YOUR VEHICLE MANUFACTURER'S RECOMMENDED TOWING CAPACITY**





**WEIGHT CARRYING:**  
**TRAILER WEIGHT:** 1,000 LBS.  
**TONGUE WEIGHT:** 150 LBS.

**WARNING:**  
 WE RECOMMEND THE USE OF 18050 STABILIZING STRAPS FOR ALL NON-TRAILER (WHEEL-LESS) LOADS. PLEASE SEE THE CURT CATALOG OR VISIT US ONLINE AT [WWW.CURTMFG.COM](http://WWW.CURTMFG.COM) FOR FURTHER INFORMATION.

**INSTALLATION TIME: 15 MIN.**  
 THE INSTALL TIME LISTED IS FOR PROFESSIONAL INSTALLERS. IF YOU ARE HESITANT TO UNDERTAKE THIS TASK ON YOUR OWN, CONTACT AN AUTHORIZED CURT INSTALLER FOR ADDITIONAL ASSISTANCE.

- INSTALLATION TIPS:**
- BEFORE YOU BEGIN INSTALLATION, READ ALL INSTRUCTIONS THOROUGHLY.
  - TO EASE INSTALLATION, 2 PEOPLE MAY BE REQUIRED.
  - USING PROPER TOOLS WILL GREATLY IMPROVE THE QUALITY OF THE INSTALL AND REDUCE THE TIME REQUIRED.
  - NEED HELP OR HAVE SOME QUESTIONS? CALL TECHNICAL SUPPORT AT 800.798.0813

**INSTALLATION REQUIRES:**

 <b>RATCHET</b>	 <b>TORQUE WRENCH</b>	 <b>12mm 13mm SOCKET</b>
 <b>SCREW DRIVER</b>	 <b>SAFETY GLASSES</b>	

**LEVEL OF DIFFICULTY: EASY**

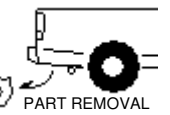
<i>EASY</i>	<i>MODERATE</i>	<i>CHALLENGING</i>
	- NO DRILLING	
	- UNDERBODY PANEL REMOVAL	

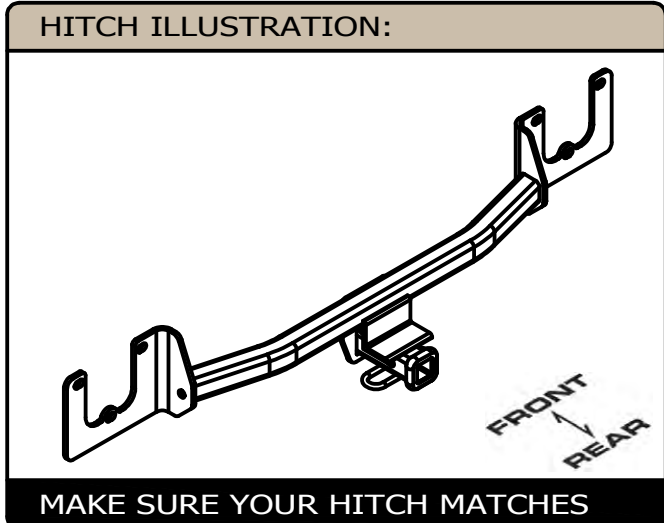
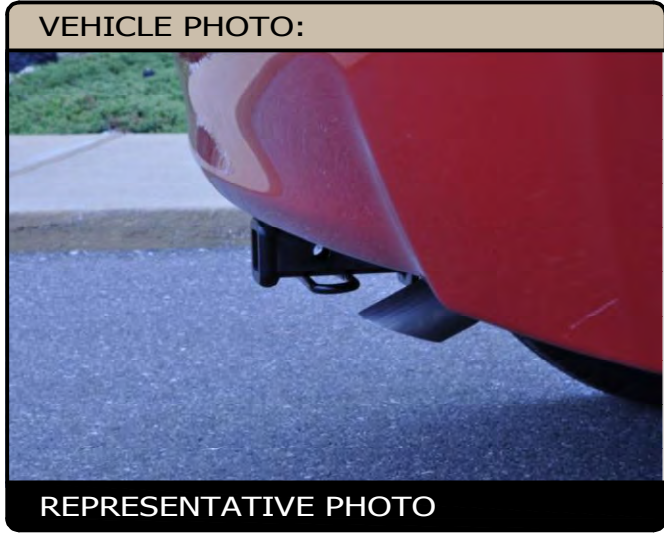

**PERIODICALLY CHECK THIS RECEIVER HITCH TO ENSURE ALL FASTENERS ARE TIGHT AND ALL STRUCTURAL COMPONENTS ARE SOUND**

CURT Manufacturing LLC. warrants this product to be free of defects in material and/or workmanship at the time of retail purchase by the original purchaser. If the product is found to be defective, Curt Manufacturing LLC. may repair or replace the product at their option, when the product is returned, prepaid, with proof of purchase. Alteration to, misuse of, or improper installation of this product voids the warranty. Curt Manufacturing LLC.'s liability is limited to repair or replacement of products found to be defective, and specifically excludes liability for incidental or consequential loss or damage.

## INSTALLATION WALKTHROUGH:

Parts List			
ITEM	QTY	PART NUMBER	DESCRIPTION
1	6	M8 - 1.25 x 30 HEX BOLT	HEX HEAD BOLT (CLASS 10.9)
2	6	3/8"	CONICAL TOOTHED WASHER

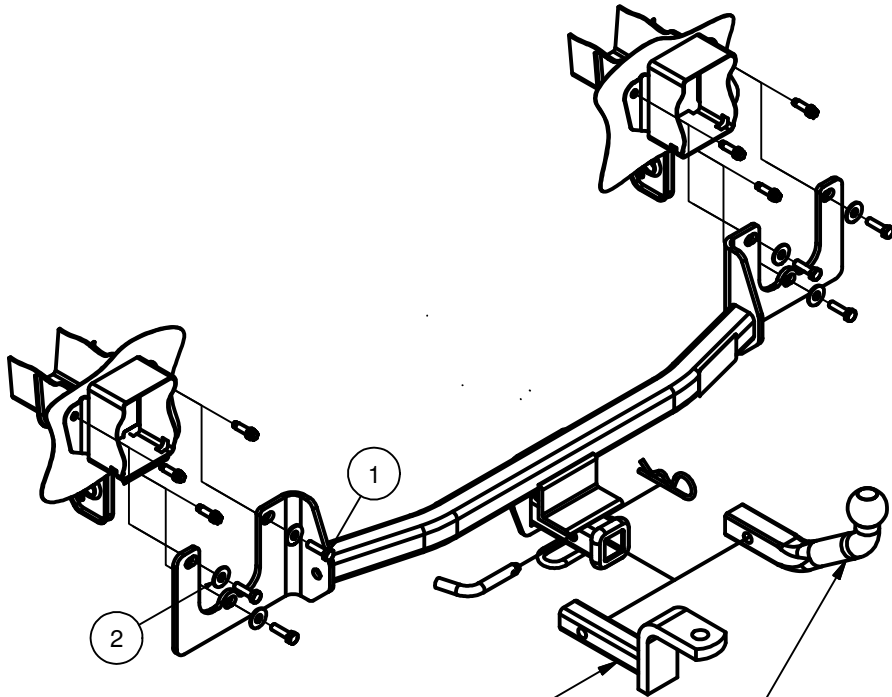

DESIGNED FOR USE WITH  
BALLMOUNT # D-55001 / 45501

EURO MOUNT OPTION AVAILABLE  
#45571 (1-7/8") AND #45572 (2" BALL)

FRONT  
↑  
↓  
REAR

1. Remove center underbody panel by removing (5) plunger style fasteners, return fasteners and panel to owner.



2. Remove (2) plunger style fasteners that secure the fascia tabs to the trunk pan. Save fasteners for reinstallation.

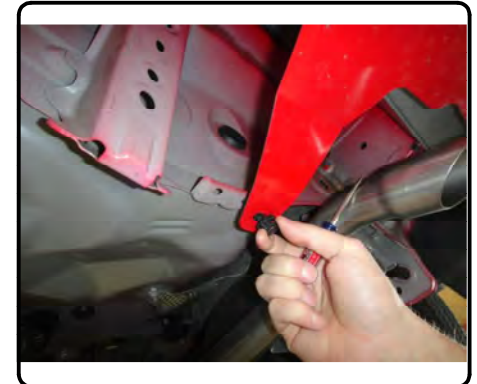
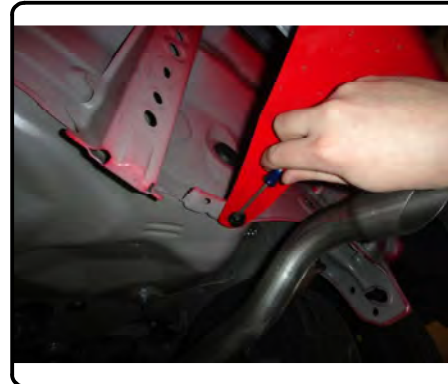

## INSTALLATION WALKTHROUGH:

3. Remove (6) bolts that secure the bumper supports to the end of the frame, return bolts to owner. **Note:** Support the bumper when removing fasteners.

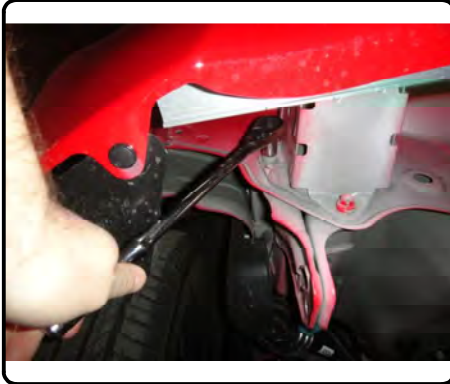

4. Gently flex fascia tabs back and raise hitch into position. Secure the hitch to the end of the frame rail using M8 hex bolts and 3/8" conical washers.

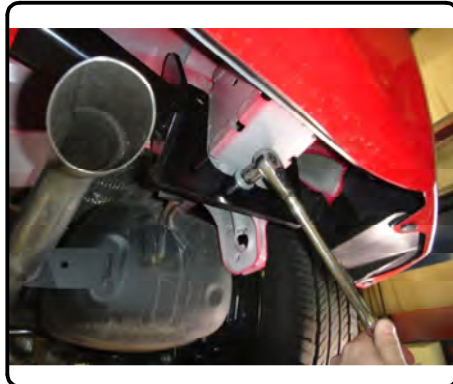
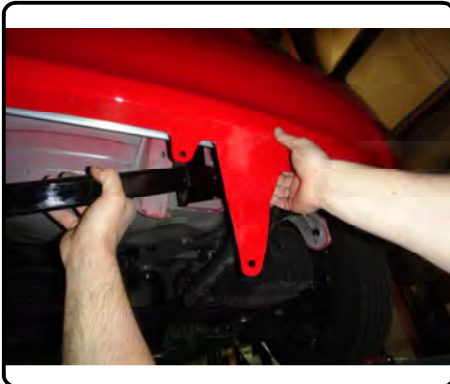

5. Torque all M8 hardware to 23 ft-lbs. Secure fascia tabs into place using fasteners removed in Step 2.

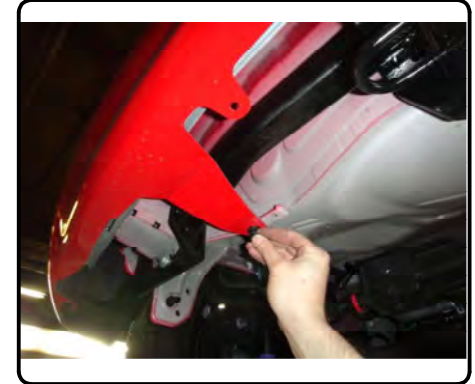

**INSTALLATION COMPLETE**





**11299****TOYOTA PRIUS c**

1/15/2013

GROSS LOAD CAPACITY WHEN USED AS A WEIGHT CARRYING HITCH: 1,000 LBS. TRAILER WEIGHT &amp; 150 LBS. TONGUE WEIGHT.

**\*\*\*DO NOT EXCEED VEHICLE MANUFACTURER'S RECOMMENDED TOWING CAPACITY.\*\*\***

WARNING: ALL NON-TRAILER LOADS APPLIED TO THIS PRODUCT MUST BE SUPPORTED BY 18050 STABILIZING STRAPS.

**\*\* FAILURE TO PROPERLY SUPPORT NON-TRAILER LOADS WILL VOID PRODUCT WARRANTY\*\***

HAVING INSTALLATION QUESTIONS? CALL TECHNICAL SUPPORT AT 1-800-798-0813

Parts List			
ITEM	QTY	PART NUMBER	DESCRIPTION
1	6	M8 - 1.25 x 30 HEX BOLT	HEX HEAD BOLT (CLASS 10.9)
2	6	3/8"	CONICAL TOOTHED WASHER

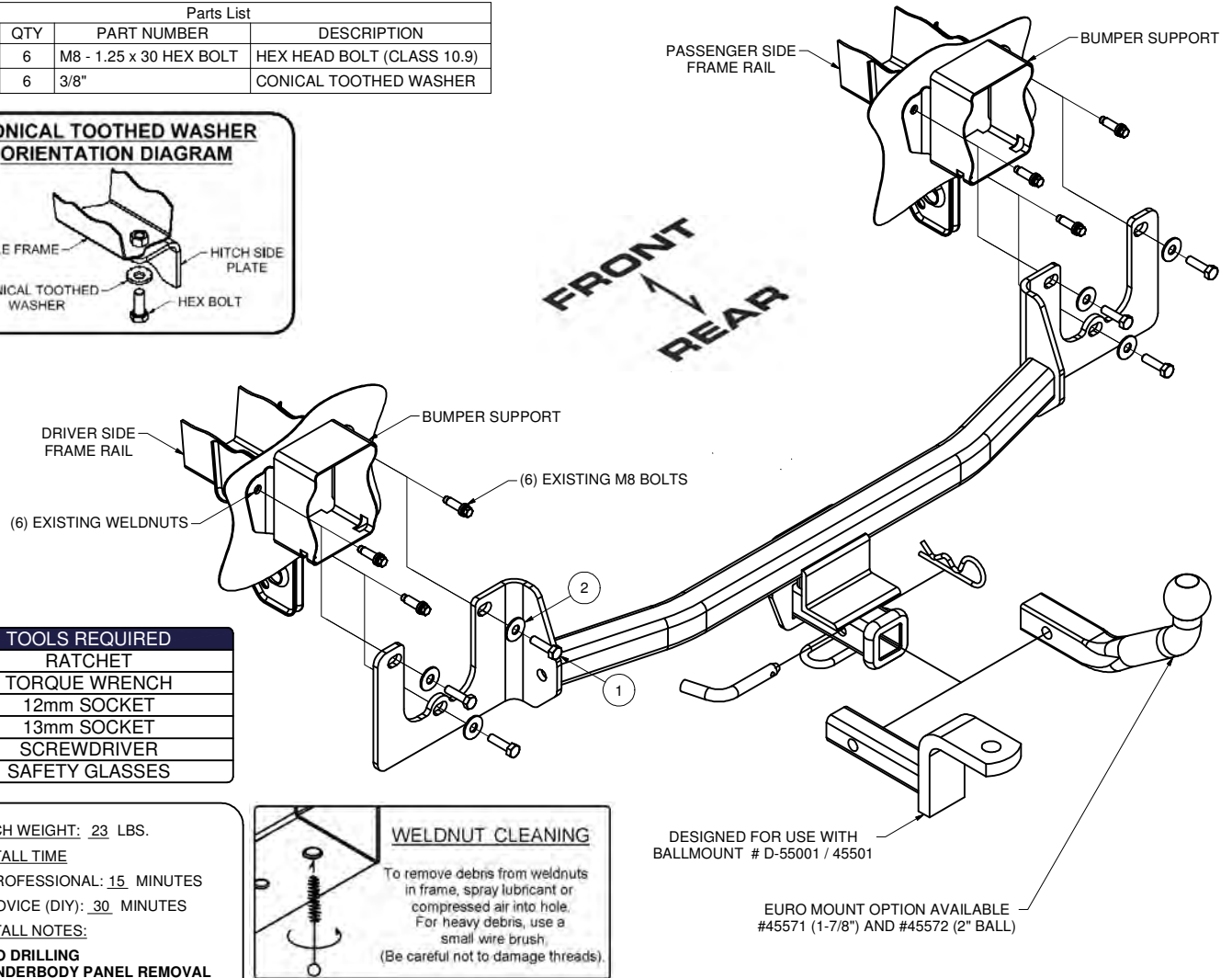
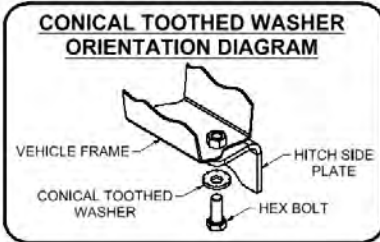

TOOLS REQUIRED
RATCHET
TORQUE WRENCH
12mm SOCKET
13mm SOCKET
SCREWDRIVER
SAFETY GLASSES

HITCH WEIGHT: 23 LBS.**INSTALL TIME**PROFESSIONAL: 15 MINUTESNOVICE (DIY): 30 MINUTES**INSTALL NOTES:**

- NO DRILLING
- UNDERBODY PANEL REMOVAL

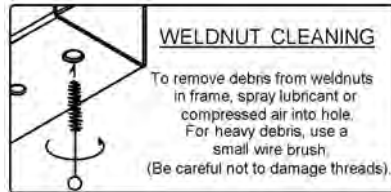
**INSTALLATION STEPS**

1. Remove center underbody panel by removing (5) plunger style fasteners, return fasteners and panel to owner.
2. Remove (2) plunger style fasteners that secure the fascia tabs to the trunk pan. Save fasteners for reinstallation.
3. Remove (6) bolts that secure the bumper supports to the end of the frame, return bolts to owner.  
**Note:** Support the bumper when removing fasteners.
4. Gently flex fascia tabs back and raise hitch into position. Secure the hitch to the end of the frame rail using M8 hex bolts and 3/8" conical washers.
5. Torque all M8 hardware to 23 ft-lbs.
6. Secure fascia tabs into place using fasteners removed in Step 2.

**PERIODICALLY CHECK THIS RECEIVER HITCH TO ENSURE THAT ALL FASTENERS ARE TIGHT AND THAT ALL STRUCTURAL COMPONENTS ARE SOUND.**

Curt Manufacturing LLC., warrants this product to be free of defects in material and/or workmanship at the time of retail purchase by the original purchaser. If the product is found to be defective, Curt Manufacturing LLC., may repair or replace the product, at their option, when the product is returned, prepaid, with proof of purchase. Alteration to, misuse of, or improper installation of this product voids the warranty. Curt Manufacturing LLC.'s liability is limited to repair or replacement of products found to be defective, and specifically excludes liability for incidental or consequential loss or damage.