



Safety glasses should be worn at all times while installing this product.

YEARS: 2013

MAKE: MITSUBISHI

MODEL: LANCER

STYLE: DE, ES, GT, SE, SPORTBACK

WARNING: NEVER EXCEED YOUR VEHICLE MANUFACTURER'S RECOMMENDED TOWING CAPACITY

WEIGHT CARRYING:
 TRAILER WEIGHT: 2,000 LBS.
 TONGUE WEIGHT: 200 LBS.

WARNING:
 WE RECOMMEND THE USE OF 18050 STABILIZING STRAPS FOR ALL NON-TRAILER (WHEEL-LESS) LOADS. PLEASE SEE THE CURT CATALOG OR VISIT US ONLINE AT WWW.CURTMFG.COM FOR FURTHER INFORMATION.

INSTALLATION TIME: 30/60 MIN.

THE INSTALL TIME LISTED IS FOR PROFESSIONAL/NOVICE INSTALLERS. IF YOU ARE HESITANT TO UNDERTAKE THIS TASK ON YOUR OWN, CONTACT AN AUTHORIZED CURT INSTALLER FOR ADDITIONAL ASSISTANCE.

INSTALLATION REQUIRES:

 RATCHET	 TORQUE WRENCH	 3/4" SOCKET
 DIE GRINDER	 10" SOCKET EXTENSION	 SAFETY GLASSES

INSTALLATION TIPS:

- BEFORE YOU BEGIN INSTALLATION, READ ALL INSTRUCTIONS THOROUGHLY.
- TO EASE INSTALLATION, 2 PEOPLE MAY BE REQUIRED.
- USING PROPER TOOLS WILL GREATLY IMPROVE THE QUALITY OF THE INSTALL AND REDUCE THE TIME REQUIRED.
- NEED HELP OR HAVE SOME QUESTIONS? CALL TECHNICAL SUPPORT AT 800.798.0813

LEVEL OF DIFFICULTY: EASY

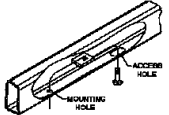
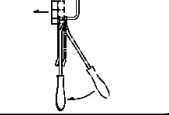
EASY	MODERATE	CHALLENGING
	- HOLE ENLARGEMENT REQUIRED	
	- FISHWIRE HARDWARE	
	- LOWER EXHAUST	

VEHICLE PHOTO:



REPRESENTATIVE PHOTO

HITCH ILLUSTRATION:

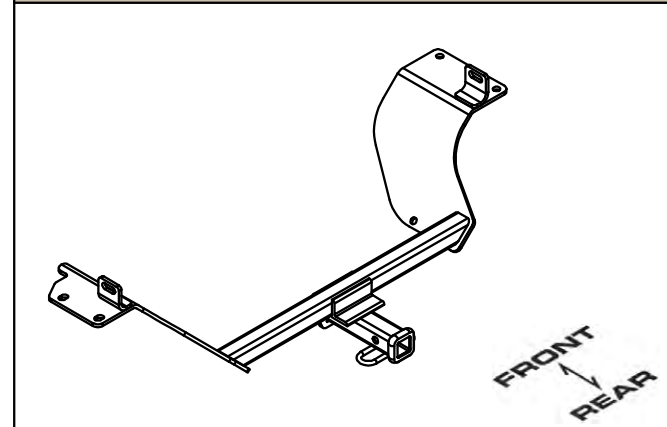

MAKE SURE YOUR HITCH MATCHES

PERIODICALLY CHECK THIS RECEIVER HITCH TO ENSURE ALL FASTENERS ARE TIGHT AND ALL STRUCTURAL COMPONENTS ARE SOUND

CURT Manufacturing LLC. warrants this product to be free of defects in material and/or workmanship at the time of retail purchase by the original purchaser. If the product is found to be defective, Curt Manufacturing LLC. may repair or replace the product at their option, when the product is returned, prepaid, with proof of purchase. Alteration to, misuse of, or improper installation of this product voids the warranty. Curt Manufacturing LLC.'s liability is limited to repair or replacement of products found to be defective, and specifically excludes liability for incidental or consequential loss or damage.

For more information log onto www.curtmfg.com, & for helpful towing tips log onto www.hitchinfo.com

INSTALLATION WALKTHROUGH:

Parts List			
ITEM	QTY	PART NUMBER	DESCRIPTION
1	6	1/2-13 x 1 1/4	CARRIAGE BOLT
2	6	HFN 1213	HEX FLANGE NUT
3	6	CM-SP6	.250 x 1.00 x 3.00" SQUARE HOLE SPACER
4	2	1_2 FISHWIRE	1/2" FISHWIRE

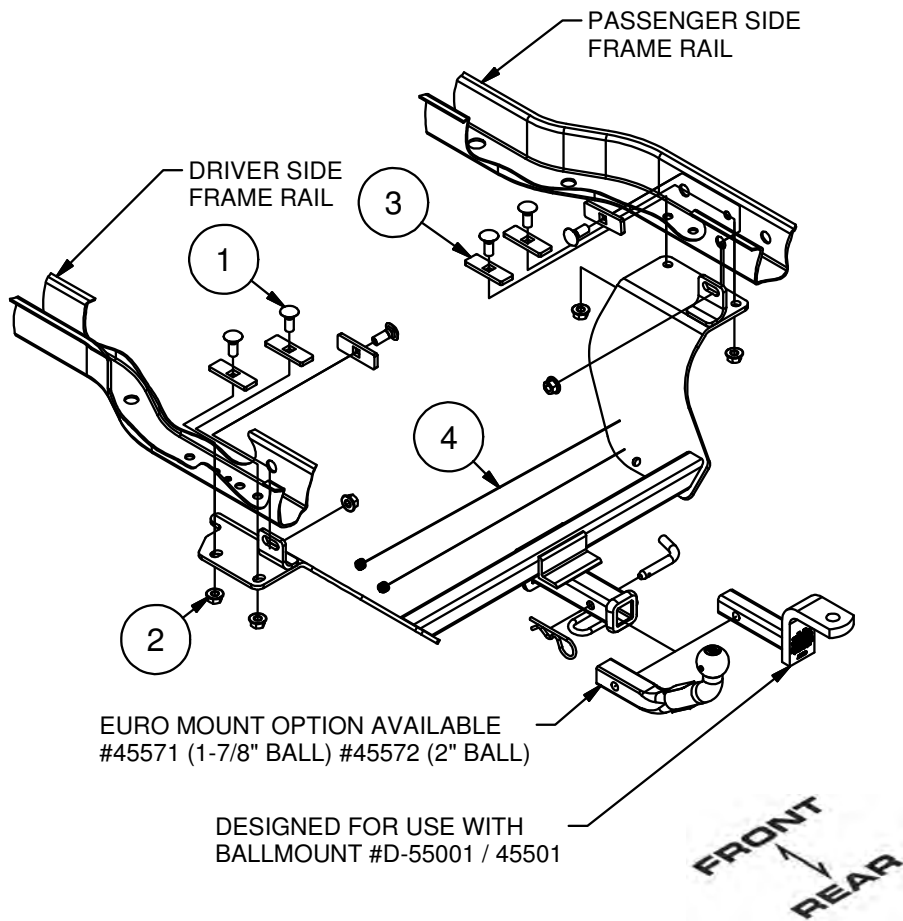

1. Lower exhaust by removing (3) rubber isolators.



RUBBER ISOLATOR REMOVAL DIAGRAM

This technique can be used if an Exhaust Hanger Removal Pliers is not available.

Using a 5/8" open end wrench, slide the wrench up to the rubber isolator, cradling the hanger rod as shown. Next place the flat edge of a pry bar between the wrench and the hanger stop or hanger rod. Then simply rotate the pry bar toward the wrench to remove the rubber isolator.

Note: Using a spray lubricant or soapy water on the hanger rod and the rubber isolator helps removal.



2. Using a die grinder with a carbide bit, enlarge the access hole on the inside of frame rail to allow the carriage bolts and spacers to fit through. (Both sides)



HOLE ENLARGEMENT DIAGRAM

INSTALLATION WALKTHROUGH:

3. Fishwire the (2) 1/2" bolts and spacers through enlarged access hole in the frame rail of vehicle and out mounting holes in bottom of frame rail. (Both sides)

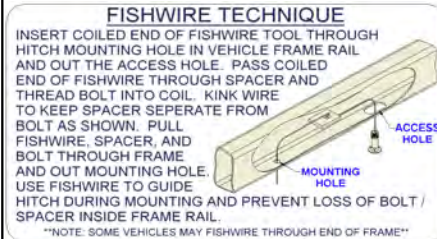
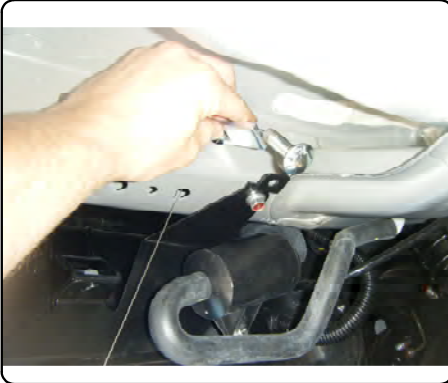

4. Raise the hitch into position and secure to vehicle with flange nuts as shown.

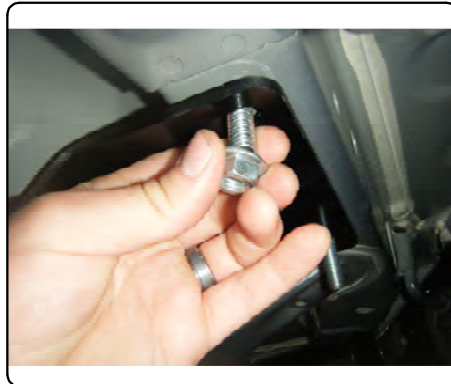

5. Fishwire remaining hardware through enlarged access hole and out the side of frame rail and tabs on hitch. Secure with flange nuts. Torque all 1/2" fasteners to 110 lb-ft. (Both sides)

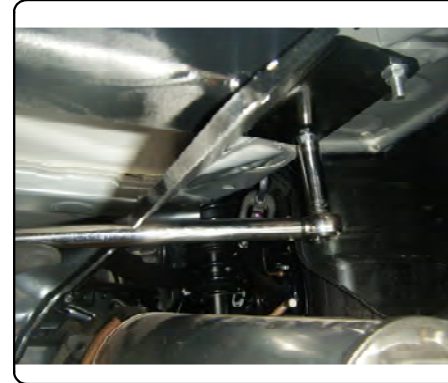

6. Reinstall exhaust isolator hangers. Install is now complete.



11328 MITSUBISHI LANCER DE, ES, GT, SE, SPORTBACK

3/13/2013

GROSS LOAD CAPACITY WHEN USED AS A WEIGHT CARRYING HITCH: 2,000 LBS. TRAILER WEIGHT & 200 LBS. TONGUE WEIGHT.

*****DO NOT EXCEED VEHICLE MANUFACTURER'S RECOMMENDED TOWING CAPACITY.*****

WARNING: ALL NON-TRAILER LOADS APPLIED TO THIS PRODUCT MUST BE SUPPORTED BY AUXILIARY STABILIZING STRAPS.

**** FAILURE TO PROPERLY SUPPORT NON-TRAILER LOADS WILL VOID PRODUCT WARRANTY****

HAVING INSTALLATION QUESTIONS? CALL TECHNICAL SUPPORT AT 1-800-798-0813

Parts List			
ITEM	QTY	PART NUMBER	DESCRIPTION
1	6	1/2-13 x 1 1/4	CARRIAGE BOLT
2	6	CM-SP6	.250 x 1.00 x 3.00" SQUARE HOLE SPACER
3	6	HFN 1213	HEX FLANGE NUT
4	2	1_2 FISHWIRE	1/2" FISHWIRE

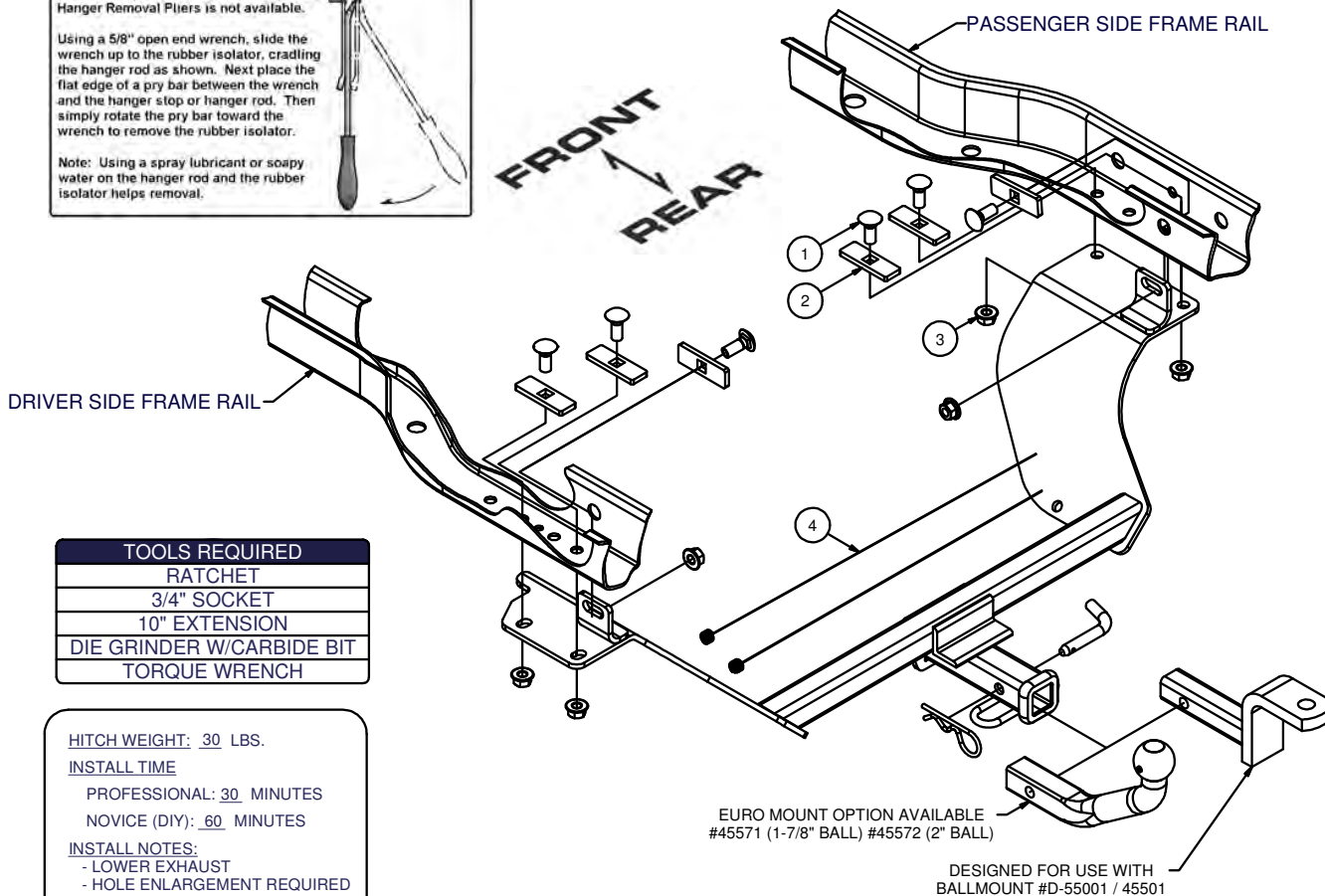
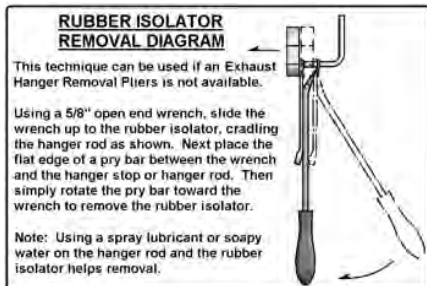
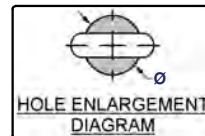
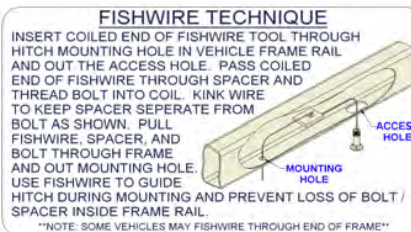

TOOLS REQUIRED
RATCHET
3/4" SOCKET
10" EXTENSION
DIE GRINDER W/CARBIDE BIT
TORQUE WRENCH

HITCH WEIGHT: 30 LBS.

INSTALL TIME

PROFESSIONAL: 30 MINUTES

NOVICE (DIY): 60 MINUTES

INSTALL NOTES:

- LOWER EXHAUST
- HOLE ENLARGEMENT REQUIRED
- FISHWIRE HARDWARE

INSTALLATION STEPS

1. Lower exhaust by removing (3) rubber isolators.
2. Using a die grinder with a carbide bit, enlarge the access hole on the inside of frame rail to allow the carriage bolts and spacers to fit through. (Both sides)
3. Fishwire the (2) 1/2" bolts and spacers through enlarged access hole in the frame rail of vehical and out mounting holes in bottom of frame rail. (Both sides)
4. Raise the hitch into position and secure to vehicle with flange nuts as shown.
5. Fishwire remaining hardware through enlarged access hole and out the side of frame rail and tabs on hitch. Secure with flange nuts. Torque all 1/2" fasteners to 110 lb-ft. (Both sides)
6. Reinstall exhaust isolator hangers.

PERIODICALLY CHECK THIS RECEIVER HITCH TO ENSURE THAT ALL FASTENERS ARE TIGHT AND THAT ALL STRUCTURAL COMPONENTS ARE SOUND.

Curt Manufacturing Inc., warrants this product to be free of defects in material and/or workmanship at the time of retail purchase by the original purchaser. If the product is found to be defective, Curt Manufacturing Inc., may repair or replace the product, at their option, when the product is returned, prepaid, with proof of purchase. Alteration to, misuse of, or improper installation of this product voids the warranty. Curt Manufacturing Inc.'s liability is limited to repair or replacement of products found to be defective, and specifically excludes liability for incidental or consequential loss or damage.