



Safety glasses should be worn at all times while installing this product.

YEARS: 2016-PRESENT
2015-PRESENT

MAKE: KIA
HYUNDAI

MODEL: OPTIMA
SONATA (INCLUDING BLUE DRIVE)

STYLE: SEDAN
SEDAN

WARNING: NEVER EXCEED YOUR VEHICLE MANUFACTURER'S RECOMMENDED TOWING CAPACITY

WEIGHT CARRYING: TRAILER WEIGHT: 2,000 LBS.
TONGUE WEIGHT: 200 LBS.

WARNING:
WE RECOMMEND THE USE OF 18050 STABILIZING STRAPS FOR ALL NON-TRAILER (WHEEL-LESS) LOADS. PLEASE SEE THE CURT CATALOG OR VISIT US ONLINE AT WWW.CURTMFG.COM FOR FURTHER INFORMATION.

PRO INSTALL TIME: 30 MIN.
NOVICE INSTALL TIME: 60 MIN.

IF YOU ARE HESITANT TO UNDERTAKE THIS TASK ON YOUR OWN, CONTACT AN AUTHORIZED CURT INSTALLER FOR ADDITIONAL ASSISTANCE.

INSTALLATION REQUIRES:

	10 mm 3/4 in	
RATCHET	SOCKET	SPRAY LUBRICANT
PRY BAR	TORQUE WRENCH	SAFETY GLASSES
DIE GRINDER		

INSTALLATION TIPS:

- BEFORE YOU BEGIN INSTALLATION, READ ALL INSTRUCTIONS THOROUGHLY.
- TO EASE INSTALLATION, 2 PEOPLE MAY BE REQUIRED.
- USING PROPER TOOLS WILL GREATLY IMPROVE THE QUALITY OF THE INSTALL AND REDUCE THE TIME REQUIRED.
- NEED HELP OR HAVE SOME QUESTIONS? CALL TECHNICAL SUPPORT AT 800.798.0813

LEVEL OF DIFFICULTY: EASY

EASY	MODERATE	CHALLENGING
	- REMOVE RUBBER EXHAUST HANGERS	
	- FISHWIRE HARDWARE	
	- REMOVE HEAT SHIELD(S)	
	- MAY REQUIRE HOLE ENLARGEMENT	
	- TRIM UNDERBODY PANEL (IF PRESENT)	

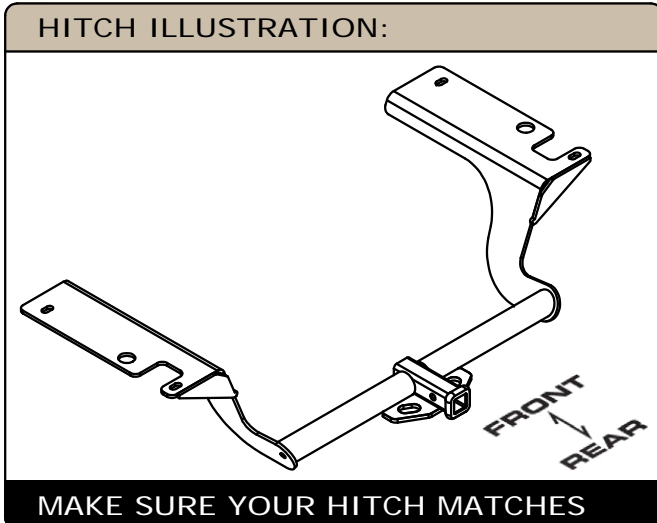

SCAN FOR MORE INFO

PERIODICALLY CHECK THIS RECEIVER HITCH TO ENSURE ALL FASTENERS ARE TIGHT AND ALL STRUCTURAL COMPONENTS ARE SOUND
CURT Manufacturing LLC. warrants this product to be free of defects in material and/or workmanship at the time of retail purchase by the original purchaser. If the product is found to be defective, CURT Manufacturing LLC. may repair or replace the product at their option, when the product is returned, prepaid, with proof of purchase. Alteration to, misuse of, or improper installation of this product voids the warranty. CURT Manufacturing LLC.'s liability is limited to repair or replacement of products found to be defective, and specifically excludes liability for incidental or consequential loss or damage. For more information log onto www.curtmfg.com, & for helpful towing tips log onto www.hitchinfo.com

INSTALLATION WALKTHROUGH:

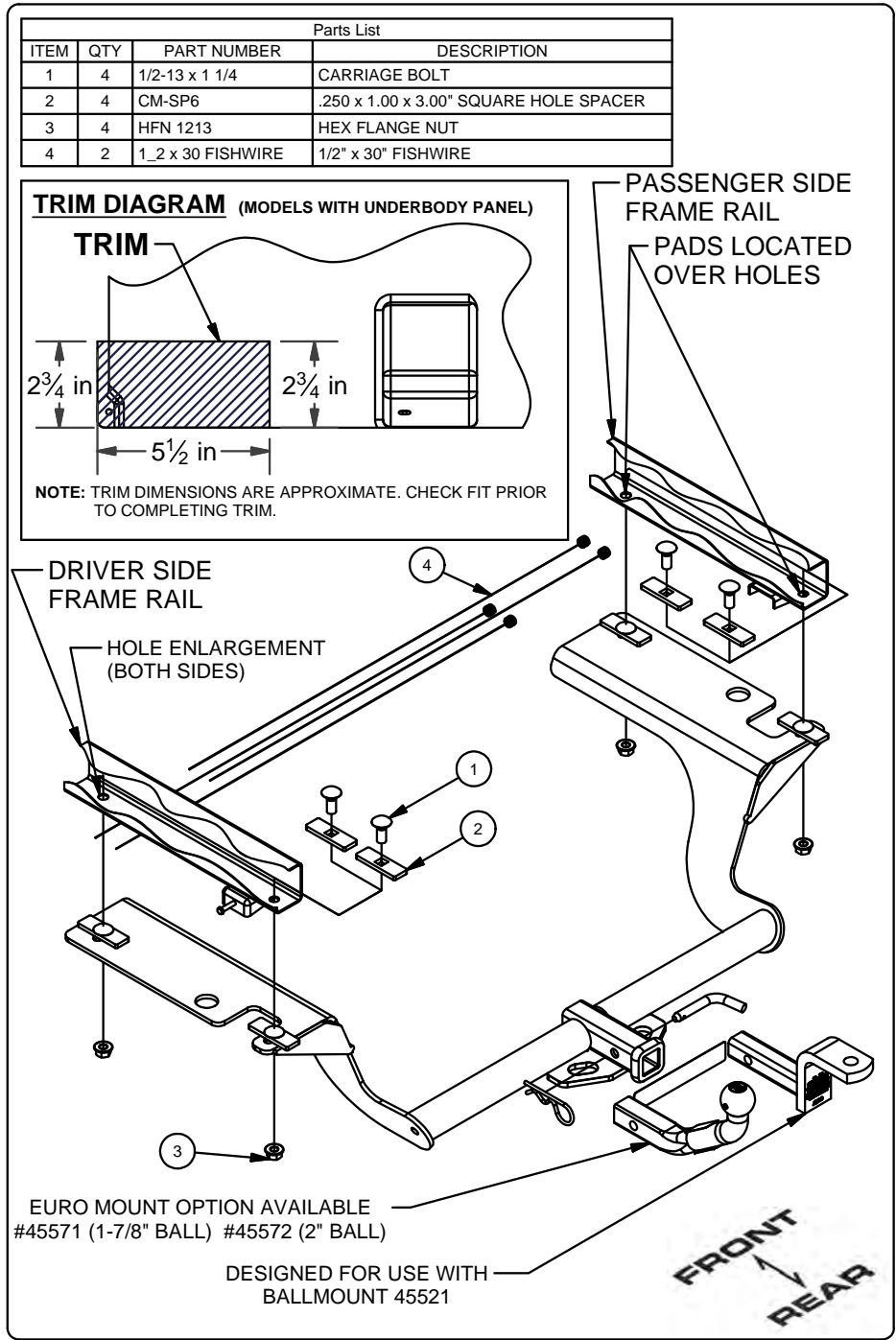

1. Remove rubber exhaust hangers and temporarily lower exhaust.
(See RUBBER ISOLATOR REMOVAL DIAGRAM below)
Note: Be sure to support exhaust to prevent damage.

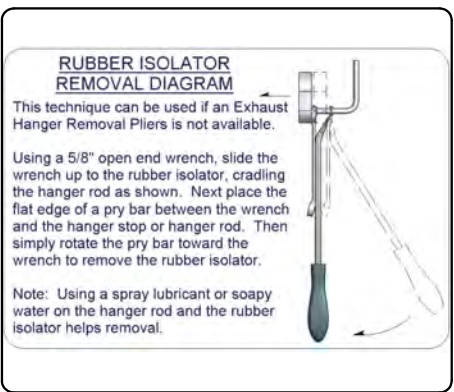

2. Temporarily remove heat shield(s) by removing (3) fasteners with a 10mm socket and remove plastic underbody panel (if present) by removing (4) plastics fasteners and (2) fasteners with a 10mm socket.



INSTALLATION WALKTHROUGH:

3. Remove (2) pads from each frame rail and discard. These pads cover holes which will be used to mount hitch. You will have to enlarge the forward-most hole to allow 1/2" bolts and spacers to pass through.



4. Fishwire 1/2" bolts and spacers into position through enlarged hole and out rear holes. Reverse fishwire 1/2" bolts and spacers into enlarged holes. (Both sides)

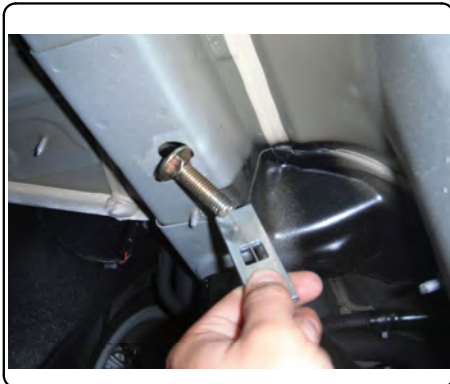

5. Raise hitch into position and attach to frame using 1/2" flange nuts.

NOTE: Be careful not to push hardware into frame when raising hitch into position.



6. Torque all 1/2" hardware to 110 ft-lbs. Reinstall heat shield(s) and leave rear most fastener off. Raise exhaust back into position. If underbody panel was present, trim and reinstall. (See TRIM DIAGRAM)

Installation complete.

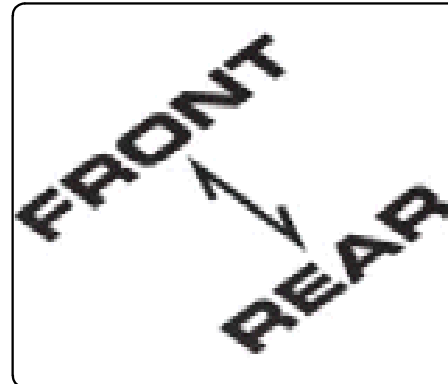

11402

HYUNDAI SONATA (INCLUDING BLUE DRIVE) & KIA OPTIMA

1/5/2016

GROSS LOAD CAPACITY WHEN USED AS A WEIGHT CARRYING HITCH: 2,000 LBS. TRAILER WEIGHT & 200 LBS. TONGUE WEIGHT.

DO NOT EXCEED VEHICLE MANUFACTURER'S RECOMMENDED TOWING CAPACITY.

WARNING: ALL NON-TRAILER LOADS APPLIED TO THIS PRODUCT MUST BE SUPPORTED BY 18050 STABILIZING STRAPS.

** FAILURE TO PROPERLY SUPPORT NON-TRAILER LOADS WILL VOID PRODUCT WARRANTY**

HAVING INSTALLATION QUESTIONS? CALL TECHNICAL SUPPORT AT 1-800-798-0813

Parts List			
ITEM	QTY	PART NUMBER	DESCRIPTION
1	4	1/2-13 x 1 1/4	CARRIAGE BOLT
2	4	CM-SP6	.250 x 1.00 x 3.00" SQUARE HOLE SPACER
3	4	HFN 1213	HEX FLANGE NUT
4	2	1_2 x 30 FISHWIRE	1/2" x 30" FISHWIRE

TOOLS REQUIRED
RATCHET
10 mm SOCKET
3/4 in SOCKET
PRY BAR
TORQUE WRENCH

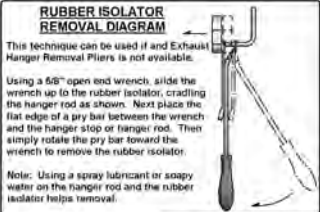
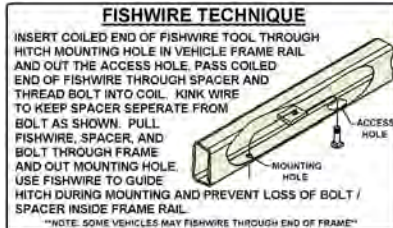
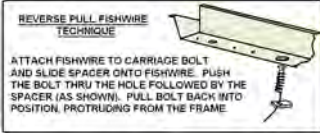

PADS LOCATED OVER HOLES
NOTE: YOU NEED TO ENLARGE THIS HOLE, BOTH SIDES.

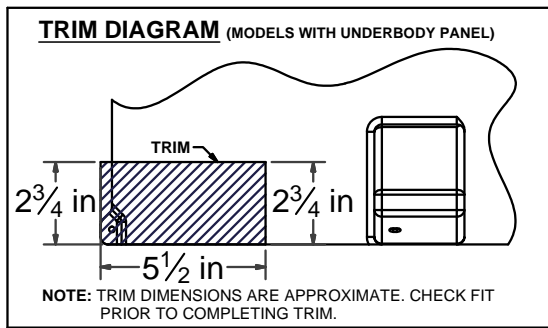
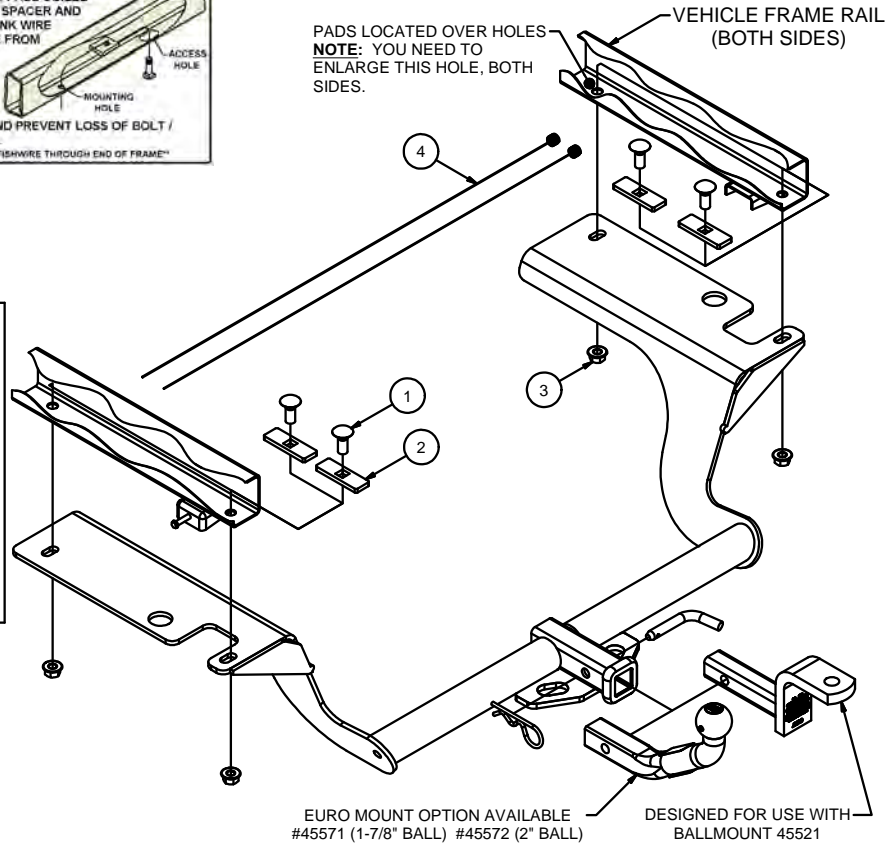

HITCH WEIGHT: 34 LBS.
 INSTALL TIME
 PROFESSIONAL: 30 MINUTES
 NOVICE (DIY): 60 MINUTES
 INSTALL NOTES:
 -MAY REQUIRE HOLE ENLARGEMENT
 -FISHWIRE HARDWARE
 -LOWER EXHAUST
 -REMOVE HEAT SHIELD

INSTALLATION STEPS

1. Remove rubber exhaust hangers and temporarily lower exhaust. (See RUBBER ISOLATOR REMOVAL DIAGRAM)
Note: Be sure to support exhaust to prevent damage.
2. Temporarily remove heat shield(s) by removing (4) fasteners with a 10mm socket and remove plastic underbody panel (if present) by removing (4) plastic fasteners and (2) hex nuts with a 10mm socket.
3. Remove (2) pads from each frame rail and discard. These pads cover holes which will be used to mount hitch. You will have to enlarge the forward-most hole to allow 1/2" bolts and spacers to pass through.
4. Fishwire 1/2" bolts and spacers into position through enlarges hole and out rear holes. Reverse fishwire 1/2" bolts and spacers into enlarged holes. (Both sides) (See FISHWIRE TECHNIQUE DIAGRAMS)
5. Raise hitch into position and attach to frame using 1/2" flange nuts.
6. Torque all 1/2" hardware to 110 ft-lbs. Reinstall heat shield(s) and leave rear most fastener off, may have to slot front hole in heat shield. Raise exhaust back into position. If underbody panel was present, trim and reinstall. (See TRIM DIAGRAM)



Scan for more information

PERIODICALLY CHECK THIS RECEIVER HITCH TO ENSURE THAT ALL FASTENERS ARE TIGHT AND THAT ALL STRUCTURAL COMPONENTS ARE SOUND.

CURT Manufacturing LLC., warrants this product to be free of defects in material and/or workmanship at the time of retail purchase by the original purchaser. If the product is found to be defective, CURT Manufacturing LLC., may repair or replace the product, at their option, when the product is returned, prepaid, with proof of purchase. Alteration to, misuse of, or improper installation of this product voids the warranty. CURT Manufacturing LLC.'s liability is limited to repair or replacement of products found to be defective, and specifically excludes liability for incidental or consequential loss or damage.