



Safety glasses should be worn at all times while installing this product.

YEARS: 2006-PRESENT

MAKE: HONDA / ACURA

MODEL: CIVIC INCLUDING SI / CSX (CANADA ONLY) / ILX (EXCLUDING HYBRID)

STYLE: SEDAN & COUPE

**WARNING: NEVER EXCEED YOUR VEHICLE MANUFACTURER'S RECOMMENDED TOWING CAPACITY**

**WEIGHT CARRYING:**  
 TRAILER WEIGHT: 2,000 LBS.  
 TONGUE WEIGHT: 200 LBS.

**WARNING:**  
 WE RECOMMEND THE USE OF 18050 STABILIZING STRAPS FOR ALL NON-TRAILER (WHEEL-LESS) LOADS. PLEASE SEE THE CURT CATALOG OR VISIT US ONLINE AT [WWW.CURTMFG.COM](http://WWW.CURTMFG.COM) FOR FURTHER INFORMATION.



**INSTALLATION TIME: 30 MIN.**

THE INSTALL TIME LISTED IS FOR PROFESSIONAL INSTALLERS. IF YOU ARE HESITANT TO UNDERTAKE THIS TASK ON YOUR OWN, CONTACT AN AUTHORIZED CURT INSTALLER FOR ADDITIONAL ASSISTANCE.

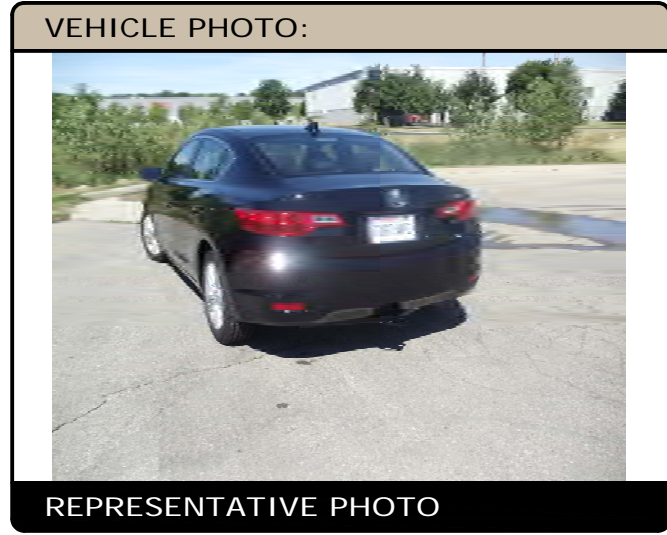



- INSTALLATION TIPS:**
- BEFORE YOU BEGIN INSTALLATION, READ ALL INSTRUCTIONS THOROUGHLY.
  - TO EASE INSTALLATION, 2 PEOPLE MAY BE REQUIRED.
  - USING PROPER TOOLS WILL GREATLY IMPROVE THE QUALITY OF THE INSTALL AND REDUCE THE TIME REQUIRED.
  - NEED HELP OR HAVE SOME QUESTIONS? CALL TECHNICAL SUPPORT AT 800.798.0813



**INSTALLATION REQUIRES:**

 TORQUE WRENCH	 RATCHET	 10mm 9/16" 11/16" 3/4" SOCKET
 AVIATION SHEARS	 PRY BAR	

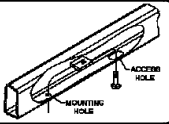
**LEVEL OF DIFFICULTY: MODERATE**

EASY	MODERATE	CHALLENGING
	TEMPORARILY LOWER EXHAUST	
	TRIM HEAT SHIELD AND UNDERBODY PANEL	
	FISHWIRE HARDWARE	
	NO DRILLING REQUIRED	

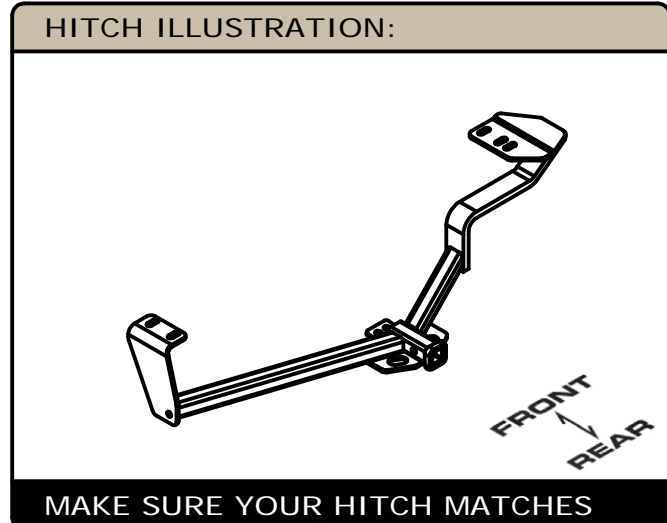

**PERIODICALLY CHECK THIS RECEIVER HITCH TO ENSURE ALL FASTENERS ARE TIGHT AND ALL STRUCTURAL COMPONENTS ARE SOUND**

CURT Manufacturing LLC. warrants this product to be free of defects in material and/or workmanship at the time of retail purchase by the original purchaser. If the product is found to be defective, Curt Manufacturing LLC. may repair or replace the product at their option, when the product is returned, prepaid, with proof of purchase. Alteration to, misuse of, or improper installation of this product voids the warranty. Curt Manufacturing LLC.'s liability is limited to repair or replacement of products found to be defective, and specifically excludes liability for incidental or consequential loss or damage.

For more information log onto [www.curtmfg.com](http://www.curtmfg.com), & for helpful towing tips log onto [www.hitchinfo.com](http://www.hitchinfo.com)

# INSTALLATION WALKTHROUGH:

Parts List			
ITEM	QTY	PART NUMBER	DESCRIPTION
1	2	7/16-14	HEX FLANGE NUT
2	2	1/2-13 x 1 1/4	HEX BOLT
3	2	1/2"	CONICAL TOOTHED WASHER
4	2	1/2-13	HANDLE NUT
5	2	CM-SP2	.250 x .88 x 2.25" SQUARE HOLE SPACER
6	2	7/16-14 x 1 1/2	CARRIAGE BOLT
7	1	CM-438-FW	7/16" FISHWIRE TOOL
8	1	3_8 - 16 x 1.00 x 1.88	U-BOLT
9	2	HFN3816	HEX FLANGE NUT

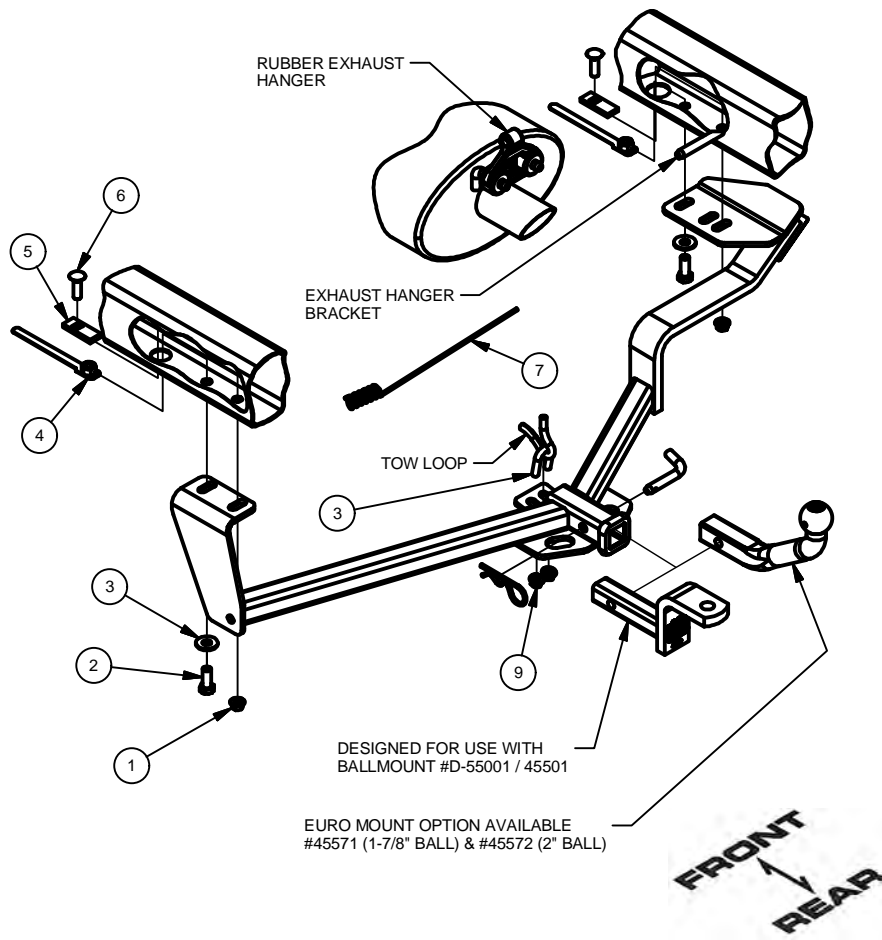

1. Lower rear rubber exhaust hanger from frame attachment. (See Rubber Isolator Removal Diagram)



2. If present, remove underbody panel. This panel will be trimmed and reinstalled. Remove (4) fasteners that attach heat shield. Save fasteners and shield for re-installation. Trim heat shield and panel as shown.



## INSTALLATION WALKTHROUGH:

3. Insert the 3/8" U-bolt through the tow loop.



4. Fishwire 7/16" carriage bolts and spacers into existing holes in frame as shown. (See Fishwire Technique)

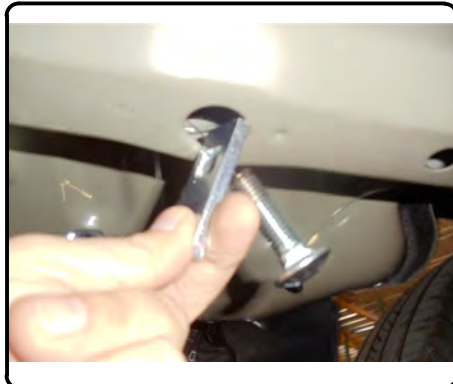

5. Insert 1/2" handle nuts through access holes. (Both sides)

6. Reattach trimmed heat shield and trimmed underbody panel using existing fasteners removed in Step 2.



7. Raise hitch and muffler simultaneously into position on passenger side and loosely secure the driver and passenger side with fasteners, as shown.



## INSTALLATION WALKTHROUGH:

8. Attach hitch to tow loop as shown.
9. Torque all 3/8" hardware to 45 ft-lbs.  
Torque all 7/16" hardware to 70 lb-ft.  
Torque all 1/2" hardware to 110 lb-ft.



Installation is complete.





# 11437 HONDA CIVIC INCLUDING Si / ACURA CSX (CANADIAN ONLY) /ACURA ILX (EXCLUDING HYBRID)

7/13/2012

GROSS LOAD CAPACITY WHEN USED AS A WEIGHT CARRYING HITCH: 2,000 LBS. TRAILER WEIGHT & 200 LBS. TONGUE WEIGHT.

\*\*\*DO NOT EXCEED VEHICLE MANUFACTURER'S RECOMMENDED TOWING CAPACITY.\*\*\*

WARNING: ALL NON-TRAILER LOADS APPLIED TO THIS PRODUCT MUST BE SUPPORTED BY AUXILIARY STABILIZING STRAPS.

\*\* FAILURE TO PROPERLY SUPPORT NON-TRAILER LOADS WILL VOID PRODUCT WARRANTY\*\*

HAVING INSTALLATION QUESTIONS? CALL TECHNICAL SUPPORT AT 1-800-798-0813

Parts List			
ITEM	QTY	PART NUMBER	DESCRIPTION
1	2	7/16-14	HEX FLANGE NUT
2	2	1/2-13 x 1 1/4	HEX BOLT
3	2	1/2"	CONICAL TOOTHED WASHER
4	2	1/2-13	HANDLE NUT
5	2	CM-SP2	.250 x .88 x 2.25" SQUARE HOLE SPACER
6	2	7/16-14 x 1 1/2	CARRIAGE BOLT
7	1	CM-438-FW	7/16" FISHWIRE TOOL
8	1	3_8 - 16 x 1.00 x 1.88	U-BOLT
9	2	HFN3816	HEX FLANGE NUT

TOOLS REQUIRED
TORQUE WRENCH
RATCHET
SOCKET 10mm, 9/16", 11/16", 3/4"
COMBINATION WRENCH 11/16"
FLAT SCREW DRIVER
PRYBAR
TIN SNIPS

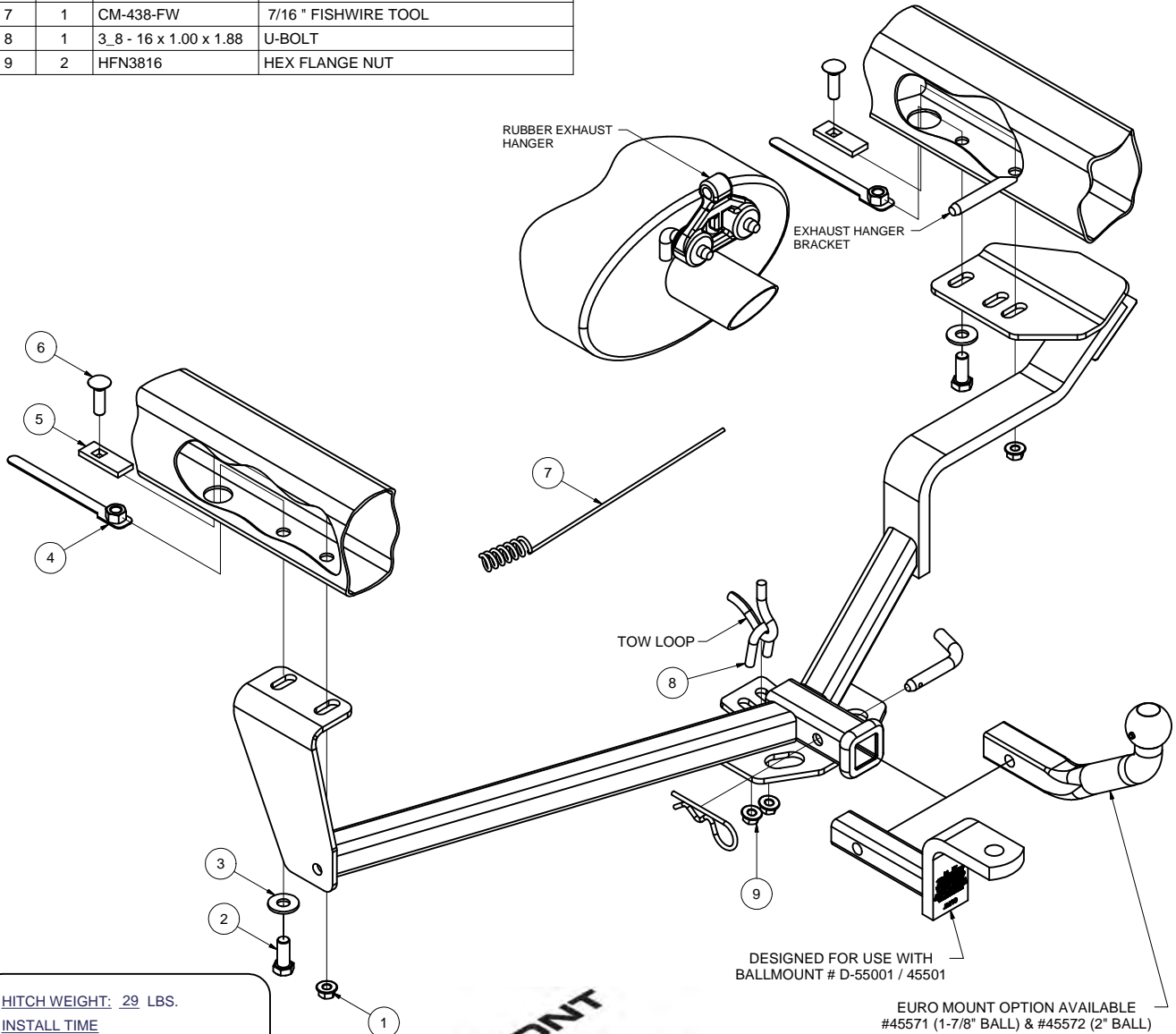

**HITCH WEIGHT:** 29 LBS.  
**INSTALL TIME**  
 PROFESSIONAL: 30 MINUTES  
 NOVICE (DIY): 60 MINUTES  
**INSTALL NOTES:**  
 -NO DRILLING REQUIRED  
 -FISHWIRE HARDWARE  
 -REMOVE PLASTIC TRUNK SHIELD  
 -REMOVE MUFFLER & TRIM HEAT SHIELD  
 -LOWER EXHAUST

**PERIODICALLY CHECK THIS RECEIVER HITCH TO ENSURE THAT ALL FASTENERS ARE TIGHT AND THAT ALL STRUCTURAL COMPONENTS ARE SOUND.**

Curt Manufacturing Inc., warrants this product to be free of defects in material and/or workmanship at the time of retail purchase by the original purchaser. If the product is found to be defective, Curt Manufacturing Inc., may repair or replace the product, at their option, when the product is returned, prepaid, with proof of purchase. Alteration to, misuse of, or improper installation of this product voids the warranty. Curt Manufacturing Inc.'s liability is limited to repair or replacement of products found to be defective, and specifically excludes liability for incidental or consequential loss or damage.

# 11437 HONDA CIVIC INCLUDING Si / ACURA CSX (CANADIAN ONLY) /ACURA ILX (EXCLUDING HYBRID)

GROSS LOAD CAPACITY WHEN USED AS A WEIGHT CARRYING HITCH: 2,000 LBS. TRAILER WEIGHT & 200 LBS. TONGUE WEIGHT.

\*\*\*DO NOT EXCEED VEHICLE MANUFACTURER'S RECOMMENDED TOWING CAPACITY.\*\*\*

WARNING: ALL NON-TRAILER LOADS APPLIED TO THIS PRODUCT MUST BE SUPPORTED BY AUXILIARY STABILIZING STRAPS.

\*\* FAILURE TO PROPERLY SUPPORT NON-TRAILER LOADS WILL VOID PRODUCT WARRANTY\*\*

HAVING INSTALLATION QUESTIONS? CALL TECHNICAL SUPPORT AT 1-800-798-0813

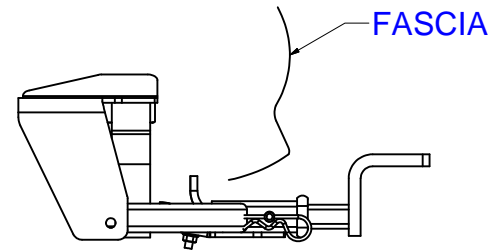
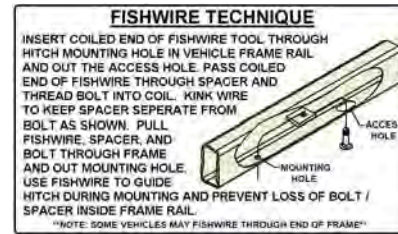
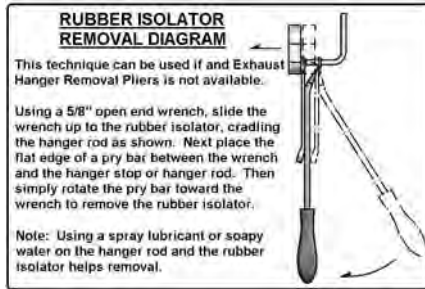

INSTALLED HITCH POSITION

## INSTALLATION STEPS

1. Lower rear rubber exhaust hanger from frame attachment. (See Rubber Isolator Removal Diagram)
2. If present, remove underbody panel. This panel will be trimmed and re-installed. Remove (4) fasteners that attach heat shield. Save fasteners and shield for re-installation. Trim heat shield and panel as shown.
3. Insert the 3/8" U-bolt through the tow loop.
4. Fishwire 7/16" carriage bolts and spacers into existing holes in frame as shown. (See Fishwire Technique)
5. Insert 1/2" handle nuts through access holes. (Both sides)
6. Re-attach trimmed heat shield and trimmed underbody panel using existing fasteners removed in Step 2.
7. Raise hitch and muffler simultaneously into position on passenger side and loosely secure the driver and passenger side with fasteners, as shown.
8. Attach hitch to the tow loop as shown.
9. Torque all 3/8" hardware to 45 ft-lbs.  
Torque 7/16" hardware to 70 lb-ft.  
Torque all 1/2" hardware to 110 lb-ft.

**PERIODICALLY CHECK THIS RECEIVER HITCH TO ENSURE THAT ALL FASTENERS ARE TIGHT AND THAT ALL STRUCTURAL COMPONENTS ARE SOUND.**

Curt Manufacturing Inc., warrants this product to be free of defects in material and/or workmanship at the time of retail purchase by the original purchaser. If the product is found to be defective, Curt Manufacturing Inc., may repair or replace the product, at their option, when the product is returned, prepaid, with proof of purchase. Alteration to, misuse of, or improper installation of this product voids the warranty. Curt Manufacturing Inc.'s liability is limited to repair or replacement of products found to be defective, and specifically excludes liability for incidental or consequential loss or damage.