

11442

SUZUKI RENO

11/30/2012

GROSS LOAD CAPACITY WHEN USED AS A WEIGHT CARRYING HITCH: 2,000 LBS. TRAILER WEIGHT & 200 LBS. TONGUE WEIGHT.

DO NOT EXCEED VEHICLE MANUFACTURER'S RECOMMENDED TOWING CAPACITY.

WARNING: ALL NON-TRAILER LOADS APPLIED TO THIS PRODUCT MUST BE SUPPORTED BY AUXILIARY STABILIZING STRAPS.

** FAILURE TO PROPERLY SUPPORT NON-TRAILER LOADS WILL VOID PRODUCT WARRANTY**

HAVING INSTALLATION QUESTIONS? CALL TECHNICAL SUPPORT AT 1-800-798-0813

Parts List			
ITEM	QTY	PART NUMBER	DESCRIPTION
1	1	CM-438-FW	7/16" FISHWIRE TOOL
2	3	FW12	FW, 12, ZP
3	1	1/2-13 x 2"	HEX BOLT
4	4	HFN 1213	HEX FLANGE NUT
5	1	CM-SP16	.250 x 1.50 x 2.00" ROUND HOLE SPACER
6	1	CM-SP2	.250 x .88 x 2.25" SQUARE HOLE SPACER
7	1	7/16-14 x 1 1/4	CARRIAGE BOLT
8	1	7/16-14	LARGE HEX FLANGE NUT
9	3	1/2-13 x 1	HEX BOLT

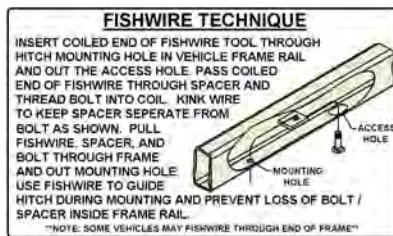

REMOVE WIRE HARNESS BRACKET BEFORE HITCH INSTALLATION

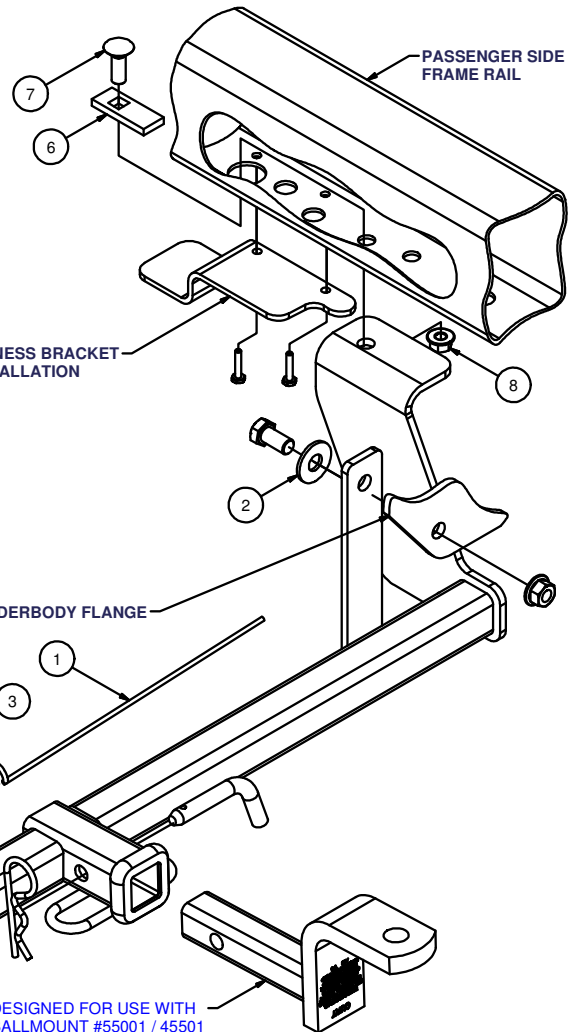
FRONT
↑
REAR

HITCH WEIGHT: 19 LBS.

INSTALL TIME

PROFESSIONAL: 35 MINUTES

NOVICE (DIY): 70 MINUTES

INSTALL NOTES:

- DRILLING REQUIRED
- LOWER BRACKET
- FISHWIRING REQUIRED

INSTALLATION STEPS

1. Remove (2) 10mm hex bolts from passenger side to remove wire harness bracket and expose frame access hole required for hitch installation.
2. Enlarge access hole as needed to allow bolt and square hole spacer to pass through. Fishwire carriage bolt and square hole spacer into hole as shown.
3. Lift hitch into position and fasten to existing holes with (2) hex bolts on driver side, and (1) hex bolt on passenger side.
4. Secure to tow loop with 2" hex bolt and spacer as shown.
5. Torque all 7/16" fasteners to 70 lb-ft and all 1/2" fasteners to 110 lb-ft.
6. Reinstall passenger side wire harness bracket that was removed in step 1.

PERIODICALLY CHECK THIS RECEIVER HITCH TO ENSURE THAT ALL FASTENERS ARE TIGHT AND THAT ALL STRUCTURAL COMPONENTS ARE SOUND.

Curt Manufacturing Inc., warrants this product to be free of defects in material and/or workmanship at the time of retail purchase by the original purchaser. If the product is found to be defective, Curt Manufacturing Inc., may repair or replace the product, at their option, when the product is returned, prepaid, with proof of purchase. Alteration to, misuse of, or improper installation of this product voids the warranty. Curt Manufacturing Inc.'s liability is limited to repair or replacement of products found to be defective, and specifically excludes liability for incidental or consequential loss or damage.

249442 / 247442