

YEARS: 2016-PRESENT

MAKE: HONDA

MODEL: CIVIC

STYLE: COUPE

WARNING: NEVER EXCEED YOUR VEHICLE MANUFACTURER'S RECOMMENDED TOWING CAPACITY
 For more information log onto www.curtmfg.com & for helpful towing tips log onto www.hitchinfo.com

WEIGHT CARRYING:
 TRAILER WEIGHT: 2,000 LBS.
 TONGUE WEIGHT: 200 LBS.

WARNING:
 WE RECOMMEND THE USE OF 18050 STABILIZING STRAPS FOR ALL NON-TRAILER (WHEEL-LESS) LOADS. PLEASE SEE THE CURT CATALOG OR VISIT US ONLINE AT WWW.CURTMFG.COM FOR FURTHER INFORMATION.

PRO INSTALL TIME: 30 MIN.
NOVICE INSTALL TIME: 60 MIN.

IF YOU ARE HESITANT TO UNDERTAKE THIS TASK ON YOUR OWN, CONTACT AN AUTHORIZED CURT INSTALLER FOR ADDITIONAL ASSISTANCE.

INSTALLATION TIPS:

- BEFORE YOU BEGIN INSTALLATION, READ ALL INSTRUCTIONS THOROUGHLY.
- TO EASE INSTALLATION, 2 PEOPLE MAY BE REQUIRED.
- USING PROPER TOOLS WILL GREATLY IMPROVE THE QUALITY OF THE INSTALL AND REDUCE THE TIME REQUIRED.
- NEED HELP OR HAVE SOME QUESTIONS? CALL TECHNICAL SUPPORT AT 800.798.0813



INSTALLATION REQUIRES:

RATCHET	TORQUE WRENCH	SOCKET EXTENSION 6"
SOCKET 10mm 11/16"	POWER DRILL	DRILL BIT 1/4", STEP
DIE GRINDER	AVIATION SHEARS	SAFETY GLASSES

LEVEL OF DIFFICULTY: MODERATE

EASY	MODERATE	CHALLENGING
	DRILLING REQUIRED	
	HOLE ENLARGEMENT REQUIRED	
	TRIMMING HEAT SHIELD(S) REQUIRED	
	TEMPORARILY REMOVE HEAT SHIELD(S)	
	FISHWIRE (4) BOLTS	

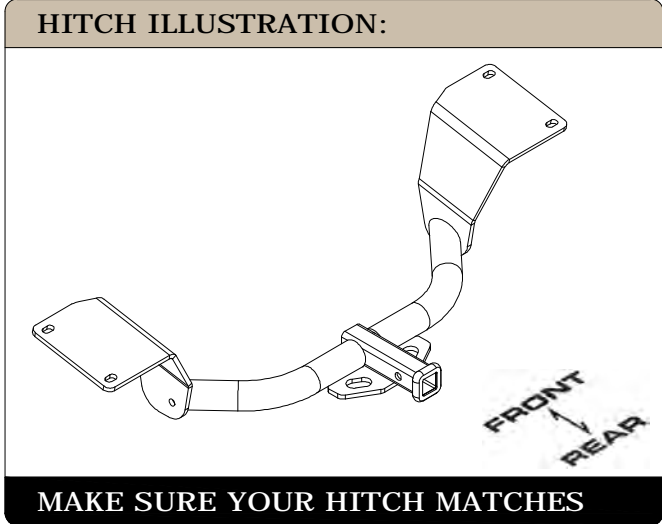

SCAN FOR MORE INFO

PERIODICALLY CHECK THIS RECEIVER HITCH TO ENSURE ALL FASTENERS ARE TIGHT AND ALL STRUCTURAL COMPONENTS ARE SOUND

CURT Manufacturing LLC. warrants this product to be free of defects in material and/or workmanship at the time of retail purchase by the original purchaser. If the product is found to be defective, CURT Manufacturing LLC. may repair or replace the product at their option, when the product is returned, prepaid, with proof of purchase. Alteration to, misuse of, or improper installation of this product voids the warranty. CURT Manufacturing LLC.'s liability is limited to repair or replacement of products found to be defective, and specifically excludes liability for incidental or consequential loss or damage.

For more information log onto www.curtmfg.com , & for helpful towing tips log onto www.hitchinfo.com

This product complies with safety specifications and requirements for connecting devices and towing systems of the state of New York, V.E.S.C.Regulation V-5 and SAE J684.

INSTALLATION WALKTHROUGH:

Parts List			
ITEM	QTY	PART NUMBER	DESCRIPTION
1	4	7/16-14 x 1 1/2	CARRIAGE BOLT
2	4	CM-SP2	.250 x .88 x 2.25" SQUARE HOLE SPACER
3	4	7/16"	7/16" CONICAL TOOTHED WASHER
4	4	7/16-14	HEX FLANGE NUT
5	4	7_16 FISHWIRE	7/16" FISHWIRE

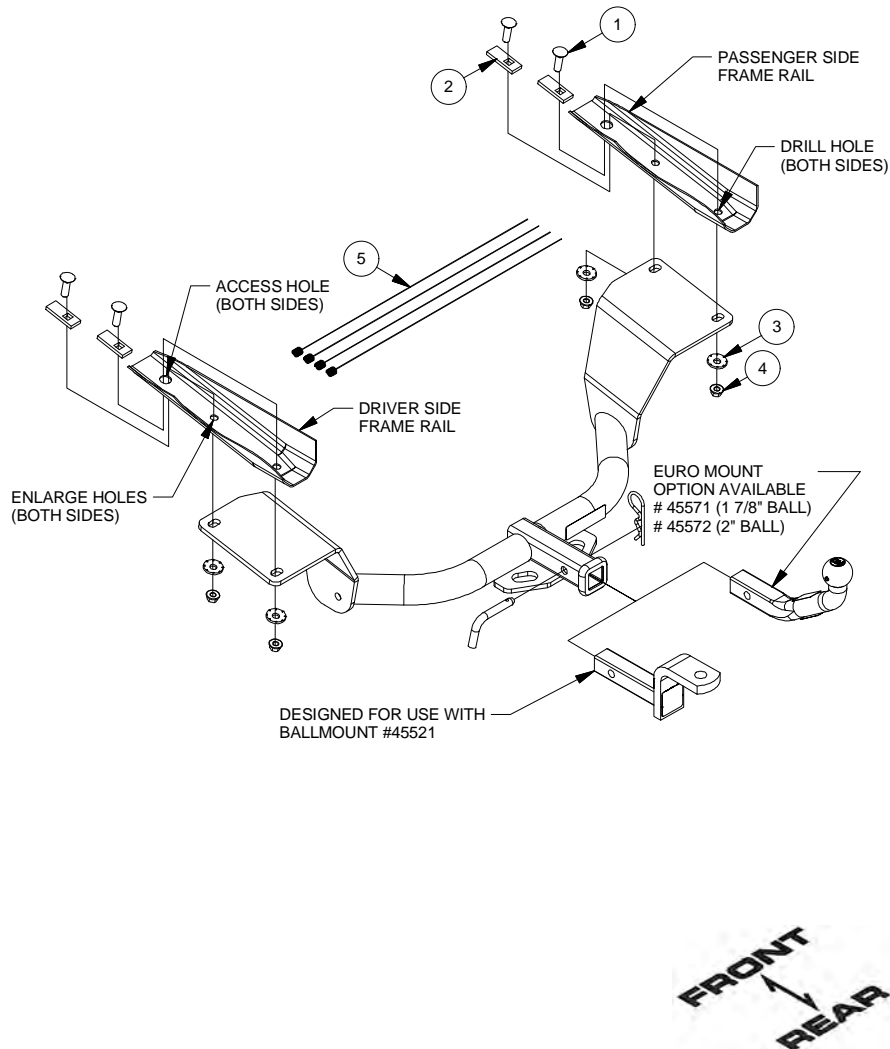

1. Remove (2) plastic push pins using a screwdriver and remove the plastic tip cover. Locate and remove (2) rubber isolators to lower the exhaust. Set plastic tip cover aside for later reinstallation. **NOTE:** if vehicle is dual exhaust, remove (4) plastic push pins and remove (4) rubber isolators, (2) per side.

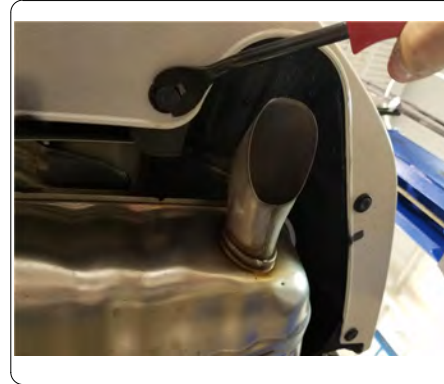

2. Locate and remove (3) bolts with a 10mm socket to remove the heat shield. Mark out a 9.25" x 10.50" section using masking tape and trim the heat shield. Reinstall heatshield. **NOTE:** If vehicle is dual exhaust remove (6) bolts and trim (2) heat shields. Reinstall after trim.



INSTALLATION WALKTHROUGH:

3. Raise hitch into position using the forward most holes to line up with the existing holes on the frame to mark out the (2) rear most holes. Use hitch as a template to drill the (2) rear most holes with a 1/4" bit. Lower hitch and use a step drill bit to enlarge (4) holes to 1/2" in diameter.

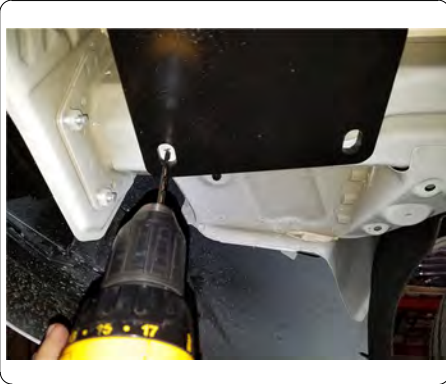

4. Fishwire (2) 7/16" carriage bolts and (2) CM-SP2 spacers through the access hole, located towards the front of the rail, into each frame rail.

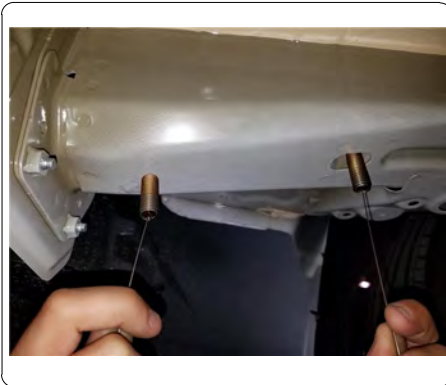
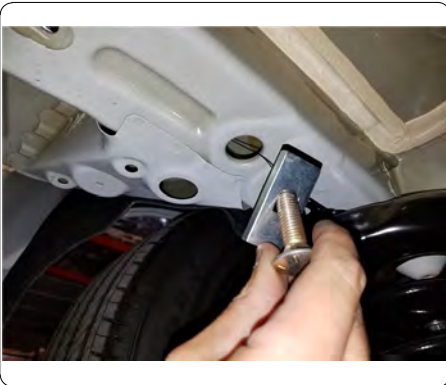

5. Raise hitch into position and loosely fasten (2) conical tooth washers and (2) 7/16" hex flange nuts on each side.

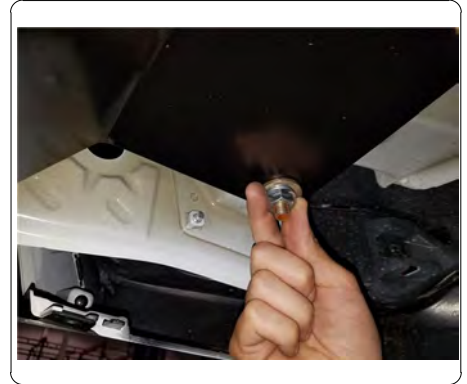
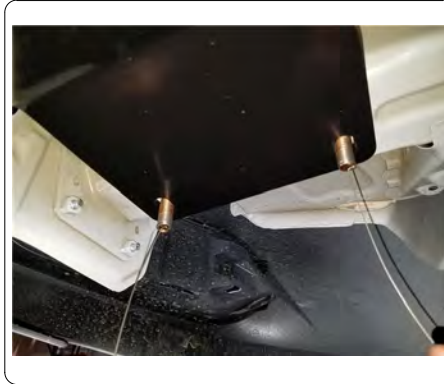

6. Torque all 7/16" hardware to 59 ft-lbs. Reinstall following Step 1 in reverse order.

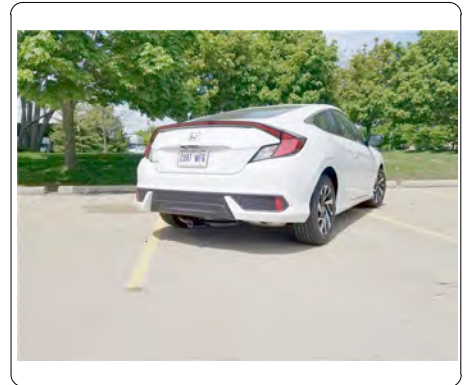

TOWING SAFETY INFORMATION

Gross Trailer Weight / GTW

The Gross Trailer Weight is the weight of the trailer & cargo. Measure this by putting the fully loaded trailer on a vehicle scale.



Tongue Weight / TW

The downward force that is exerted on the hitch ball by the coupler. The tongue weight will vary depending on where the load is positioned in relationship to the trailer axle(s). To measure the tongue weight, use either a commercial scale or a bathroom scale with the coupler at towing height. When using a bathroom scale with heavier tongue weights, use the method shown and multiply the scale reading by 3.

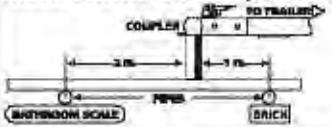

Weight Carrying / WC

The total weight of both the trailer and the cargo inside. Never exceed the weight capacity of your trailer hitch.

Weight Distribution / WD

Used to balance the weight of the cargo between the front and rear wheels throughout the trailer, allowing for better steering, braking, and level riding.



Sway Control

A device used to reduce the lateral movements of the trailer that are caused by the wind. This works in conjunction with a weight distribution hitch. Do not use this on a class 1 or 2 hitch, or with surge brakes.

How Much Can You Safely Tow?

TONGUE WEIGHT (lb)	TRAILER CLASS									
	CLASS 1	CLASS 2	CLASS 3	CLASS 4	CLASS 5	CLASS 6	CLASS 7	CLASS 8	CLASS 9	CLASS 10
1000	1100	1200	1300	1400	1500	1600				
2000										
3000										
4000										
5000										
6000										
7000										
8000										
9000										
10000										

Refer to owner's manual for towing capabilities and limitations.

Ball Mount

The ball mount is placed inside the opening of the receiver hitch which is mounted to the vehicle. Make sure a hitch pin and clip is properly securing the ball mount to the receiver hitch before you begin towing.

• A: Rise. B: Drop. C: Hole Size. D: Length.

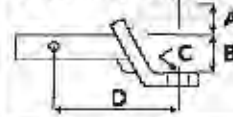

Trailer Ball

The connection from the hitch to the trailer. There are many factors that determine the correct hitch ball:

- Number one is the hitch ball's gross trailer weight rating.
- The mounting platform must be at least 3/8" thick.
- The hole diameter must not be more than 1/16" larger than the threaded shank.
- Every time you tow, check the nut and lock washer to make sure they are fastened securely.

• A: Ball Dia. B: Shank Dia. C: Shank Length. D: Shank Rise.



Coupler

The component that is placed over the trailer ball to connect the vehicle to the trailer. Be sure that the coupler size matches the size of the hitch ball and that the coupler handle is securely fastened. To determine what size hitch ball you need for your application you will need to know the size of coupler that is on the trailer. Be sure your coupler is properly adjusted to the ball you are using.

NOTE: For added security the use of safety devices such as Coupler Safety Pins and Locks is strongly recommended.

Safety Chains

Safety chains are a requirement and should be crossed under the tongue of the trailer so that the tongue will not drop to the road if it becomes separated from the hitch. Always leave enough slack so you can turn. Never allow the safety chains to drag on the ground and never attach the chains to the bumper.

Trailer Classification: Safety Chain Breaking Force - Minimum

Class 1: 2,000 lbs. (8.9 kN)

Class 2: 3,500 lbs. (15.6 kN)

Class 3: 5,000 lbs. (22.2 kN)

The strength rating of each length of safety chain or its equivalent and its attachments shall be equal to or exceed in minimum breaking force the GVWR (Gross Vehicle Weight Rating) of the trailer.

Electrical

Trailer lights, Electric Brakes, Break-away systems - Every time you tow, be sure to check that all components are working properly.

Wiring identification by color:



11445

HONDA CIVIC (COUPE)

5/27/2016

GROSS LOAD CAPACITY WHEN USED AS A WEIGHT CARRYING HITCH: 2,000 LBS. TRAILER WEIGHT & 200 LBS. TONGUE WEIGHT.

WARNING: ALL NON-TRAILER LOADS APPLIED TO THIS PRODUCT MUST BE SUPPORTED BY 18050 STABILIZING STRAPS.



WARNING: ** FAILURE TO PROPERLY SUPPORT NON-TRAILER LOADS WILL VOID PRODUCT WARRANTY **

WARNING: * DO NOT EXCEED VEHICLE MANUFACTURER'S RECOMMENDED TOWING CAPACITY *****

**FOR MORE INFORMATION LOG ONTO WWW.CURTMFG.COM & FOR HELPFUL TOWING TIPS LOG ONTO WWW.HITCHINFO.COM
HAVING INSTALLATION QUESTIONS? CALL TECHNICAL SUPPORT AT 1-800-798-0813**



Parts List				
ITEM	QTY	PART NUMBER	DESCRIPTION	
1	4	7/16-14 x 1 1/2	CARRIAGE BOLT	
2	4	CM-SP2	.250 x .88 x 2.25" SQUARE HOLE SPACER	
3	4	7/16"	7/16" CONICAL TOOTHED WASHER	
4	4	7/16-14	HEX FLANGE NUT	
5	4	7_16 FISHWIRE	7/16" FISHWIRE	

FISHWIRE TECHNIQUE
INSERT COILED END OF FISHWIRE TOOL THROUGH HITCH MOUNTING HOLE IN VEHICLE FRAME RAIL AND OUT THE ACCESS HOLE. PASS COILED END OF FISHWIRE THROUGH SPACER AND THREAD BOLT INTO COIL. KINK WIRE TO KEEP SPACER SEPARATE FROM BOLT AS SHOWN. PULL FISHWIRE, SPACER, AND BOLT THROUGH FRAME AND OUT MOUNTING HOLE. USE FISHWIRE TO GUIDE HITCH DURING MOUNTING AND PREVENT LOSS OF BOLT / SPACER INSIDE FRAME RAIL.

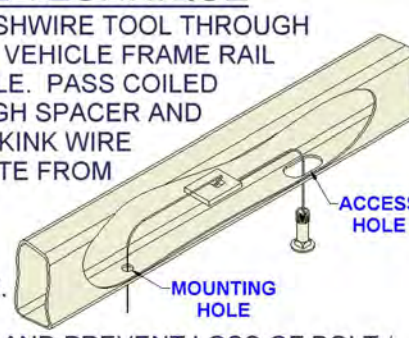

****NOTE: SOME VEHICLES MAY FISHWIRE THROUGH END OF FRAME****

RUBBER ISOLATOR REMOVAL DIAGRAM
This technique can be used if an Exhaust Hanger Removal Pliers is not available.
Using a 5/8" open end wrench, slide the wrench up to the rubber isolator, cradling the hanger rod as shown. Next place the flat edge of a pry bar between the wrench and the hanger stop or hanger rod. Then simply rotate the pry bar toward the wrench to remove the rubber isolator.
Note: Using a spray lubricant or soapy water on the hanger rod and the rubber isolator helps removal.

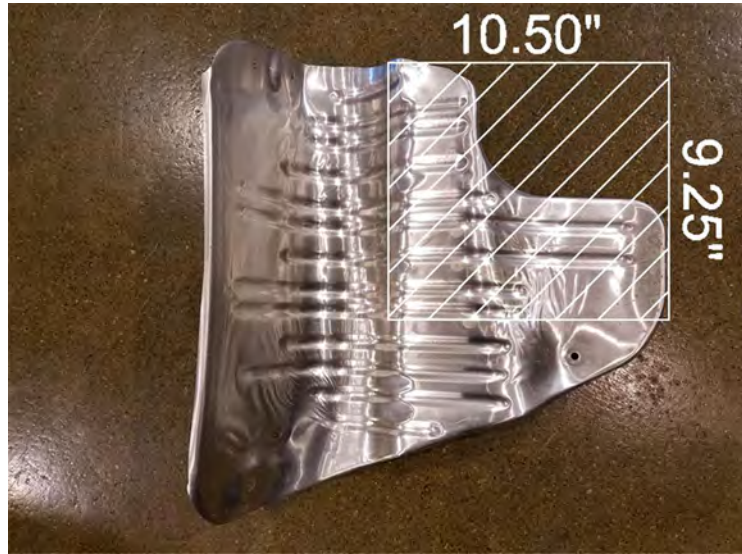
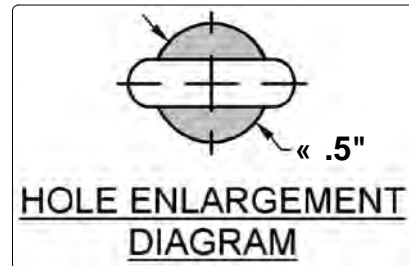
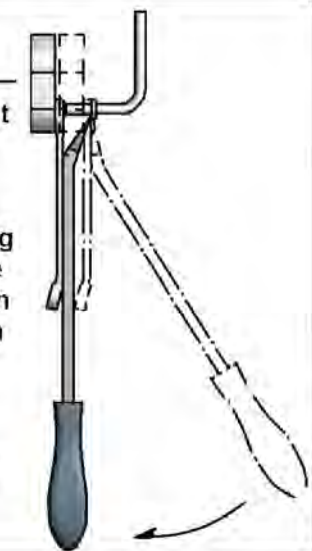

TOOLS REQUIRED
RATCHET
TORQUE WRENCH
6" SOCKET EXTENSION
10mm, 11/16" SOCKETS
1/4", STEP DRILL BIT
POWER DRILL
MASKING TAPE
AVIATION SHEARS
SAFETY GLASSES

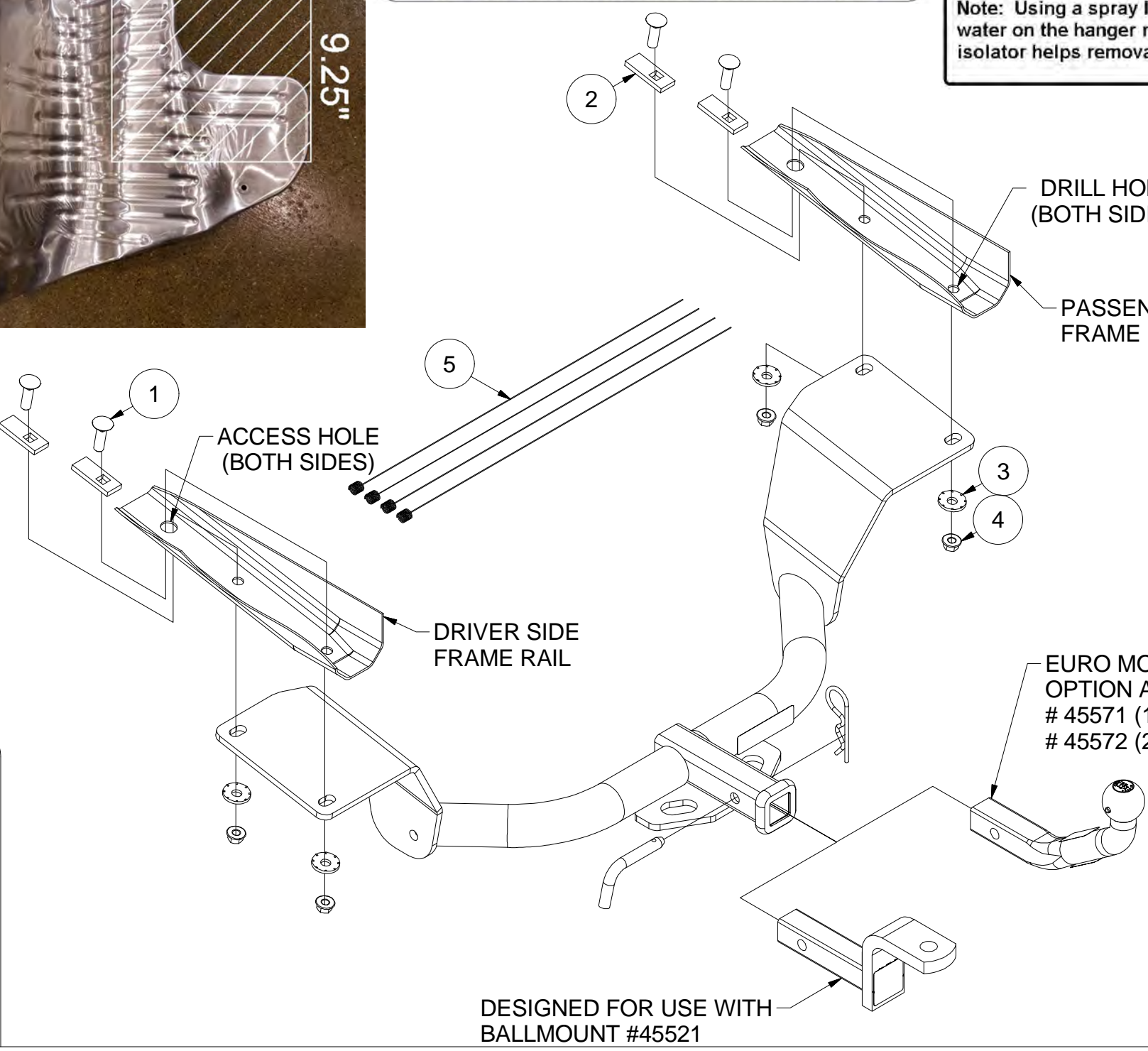

HITCH WEIGHT: 25 LBS.
INSTALL TIME
PROFESSIONAL: 30 MINUTES
NOVICE (DIY): 60 MINUTES
INSTALL NOTES:
-DRILLING REQUIRED
-TEMPORARILY REMOVE HEAT SHIELD(S)
-TRIM REQUIRED
-FISHWIRE REQUIRED
-HOLE ENLARGEMENT REQUIRED

INSTALLATION STEPS

1. Remove (2) plastic push pins using a screwdriver and remove the plastic tip cover. Locate and remove (2) rubber isolators to lower the exhaust. Set plastic tip cover aside for later reinstallation. **NOTE:** if vehicle is dual exhaust, remove (4) plastic push pins and remove (4) rubber isolators, (2) per side.
2. Locate and remove (3) bolts with a 10mm socket to remove the heat shield. Mark out a 9.25" x 10.50" section using masking tape and trim the heat shield. Reinstall heatshield. **NOTE:** If vehicle is dual exhaust remove (6) bolts and trim (2) heat shields. Reinstall after trim.
3. Raise hitch into position using the forward most holes to line up with the existing holes on the frame to mark out the (2) rear most holes. Use hitch as a template to drill the (2) rear most holes with a 1/4" drill. Lower hitch and use a step drill bit to enlarge (4) holes to 1/2" in diameter.
4. Fishwire (2) 7/16" carriage bolts and (2) CM-SP2 spacers through the access hole, located towards the front of the rail, into each frame rail.
5. Raise hitch into position and loosely fasten (2) conical tooth washers and (2) 7/16" hex flange nuts on each side.
6. Torque all 7/16" hardware to 59 ft-lbs. Reinstall following Step 1 in reverse order.



Scan for more information

PERIODICALLY CHECK THIS RECEIVER HITCH TO ENSURE THAT ALL FASTENERS ARE TIGHT AND THAT ALL STRUCTURAL COMPONENTS ARE SOUND.

CURT Manufacturing LLC., warrants this product to be free of defects in material and/or workmanship at the time of retail purchase by the original purchaser. If the product is found to be defective, CURT Manufacturing LLC., may repair or replace the product, at their option, when the product is returned, prepaid, with proof of purchase. Alteration to, misuse of, or improper installation of this product voids the warranty. CURT Manufacturing LLC.'s liability is limited to repair or replacement of products found to be defective, and specifically excludes liability for incidental or consequential loss or damage.
This product complies with safety specifications and requirements for connecting devices and towing systems of the state of New York, V.E.S.C.Regulation V-5 and SAE J684.