

11512

1977-1983 BMW 320i,323i

1977-1985 MERCEDES-BENZ 230,240D, 280E,280CE, 300D, 300CD

1974-1980 MERCEDES-BENZ 280S, 280SE, 300SD, 450E,450SEL

1978-1987 MERCEDES-BENZ 450SL, 450SLC, 380SL, 380SLC,560SL

1982-1987 VW QUANTUM WAGON EXCEPT 4 WHEEL DRIVE

1975-1984 VW RABBIT EXCEPT 1985-1986 CABRIOLET,

ALL THRU 1981 VW SCIROCOCO

1985-1986 VW CABRIOLET (CONVERTIBLE)

12/17/2012**GROSS LOAD CAPACITY WHEN USED AS A WEIGHT CARRYING HITCH: 1,500 LBS. TRAILER WEIGHT & 150 LBS. TONGUE WEIGHT.*******DO NOT EXCEED VEHICLE MANUFACTURER'S RECOMMENDED TOWING CAPACITY.*******WARNING: ALL NON-TRAILER LOADS APPLIED TO THIS PRODUCT MUST BE SUPPORTED BY 18050 STABILIZING STRAPS.****** FAILURE TO PROPERLY SUPPORT NON-TRAILER LOADS WILL VOID PRODUCT WARRANTY******HAVING INSTALLATION QUESTIONS? CALL TECHNICAL SUPPORT AT 1-800-798-0813**

Parts List			
ITEM	QTY	PART NUMBER	DESCRIPTION
1	5	3/8 - 16 x 1 1/4	HEX BOLT
2	3	3/8"	FENDER WASHER
3	5	3/8 - 16	HEX NUT
4	5	3/8"	LOCK WASHER
5	2	3/8"	WASHER

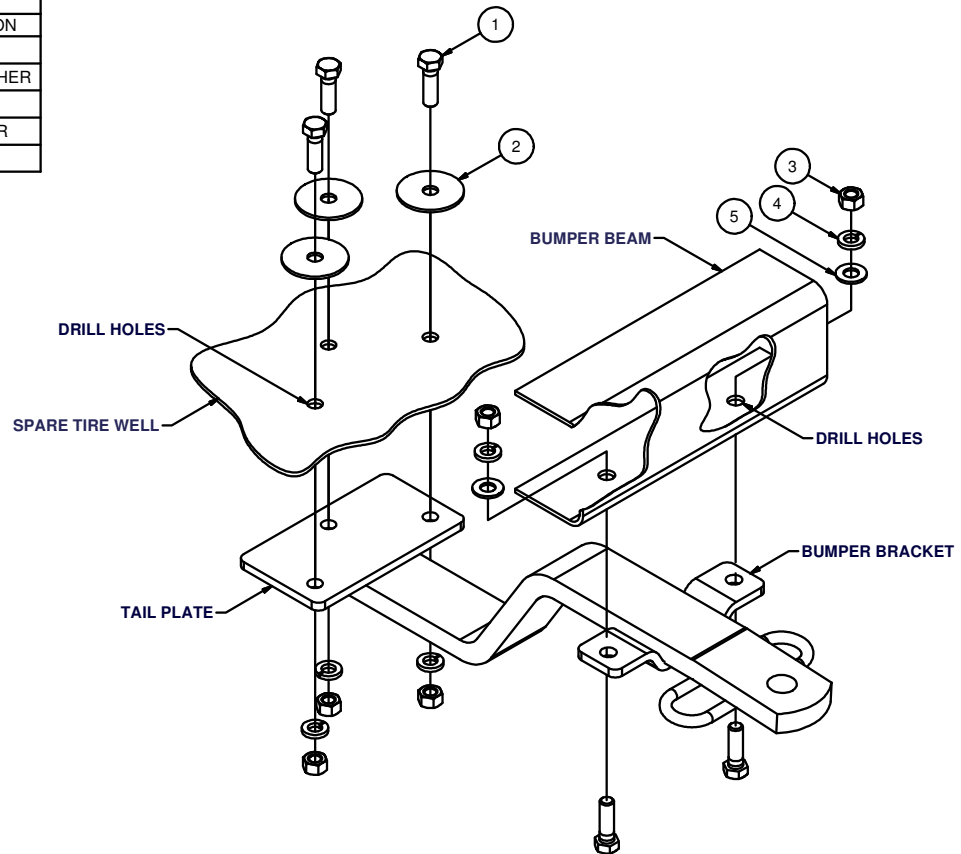
HITCH WEIGHT: 9 LBS.INSTALL TIME

PROFESSIONAL: 45 MINUTES

NOVICE (DIY): 90 MINUTES

INSTALL NOTES:

- DRILLING REQUIRED
- REMOVE SPARE TIRE
- SILICONE SEAL SPARE TIRE WELL

INSTALLATION STEPS

1. Remove the spare tire.
2. Position the hitch tail plate against the bottom of the spare tire well as shown. Support the hitch in place making sure it is square and centered on the car.
3. Using the hitch as a template, mark and drill three places in the trunk floor for 3/8" diameter fasteners. Bolt the hitch to the trunk floor using three 3/8" x 1 1/4" bolts with large fender washers on the inside of the trunk.
4. Position the bumper bracket against the bumper as shown. Mark and drill the bumper for 3/8" fasteners. Install hardware as shown.
5. Torque all 3/8" fasteners to 45 lb-ft.
6. Use silicone sealant to seal hardware installed through spare tire well.
7. Reinstall spare tire.

PERIODICALLY CHECK THIS RECEIVER HITCH TO ENSURE THAT ALL FASTENERS ARE TIGHT AND THAT ALL STRUCTURAL COMPONENTS ARE SOUND.

Curt Manufacturing Inc., warrants this product to be free of defects in material and/or workmanship at the time of retail purchase by the original purchaser. If the product is found to be defective, Curt Manufacturing Inc., may repair or replace the product, at their option, when the product is returned, prepaid, with proof of purchase. Alteration to, misuse of, or improper installation of this product voids the warranty. Curt Manufacturing Inc.'s liability is limited to repair or replacement of products found to be defective, and specifically excludes liability for incidental or consequential loss or damage.