

1152085-88 DODGE COLT, ALL HATCHBACK, 85 DODGE COLT SEDAN
85-88 MITSUBISHI MIRAGE (INCL. TURBO)

3/25/2013

GROSS LOAD CAPACITY WHEN USED AS A WEIGHT CARRYING HITCH: 1,000 LBS. TRAILER WEIGHT & 100 LBS. TONGUE WEIGHT.

*****DO NOT EXCEED VEHICLE MANUFACTURER'S RECOMMENDED TOWING CAPACITY.*****

WARNING: ALL NON-TRAILER LOADS APPLIED TO THIS PRODUCT MUST BE SUPPORTED BY 18050 STABILIZING STRAPS.

**** FAILURE TO PROPERLY SUPPORT NON-TRAILER LOADS WILL VOID PRODUCT WARRANTY****

HAVING INSTALLATION QUESTIONS? CALL TECHNICAL SUPPORT AT 1-800-798-0813

Parts List			
ITEM	QTY	PART NUMBER	DESCRIPTION
1	4	M10 - 1.25 x 40 HEX	HEX BOLT
2	4	3/8"	WASHER
3	4	7/16 LOCK WASHER	HELICAL LOCK WASHER

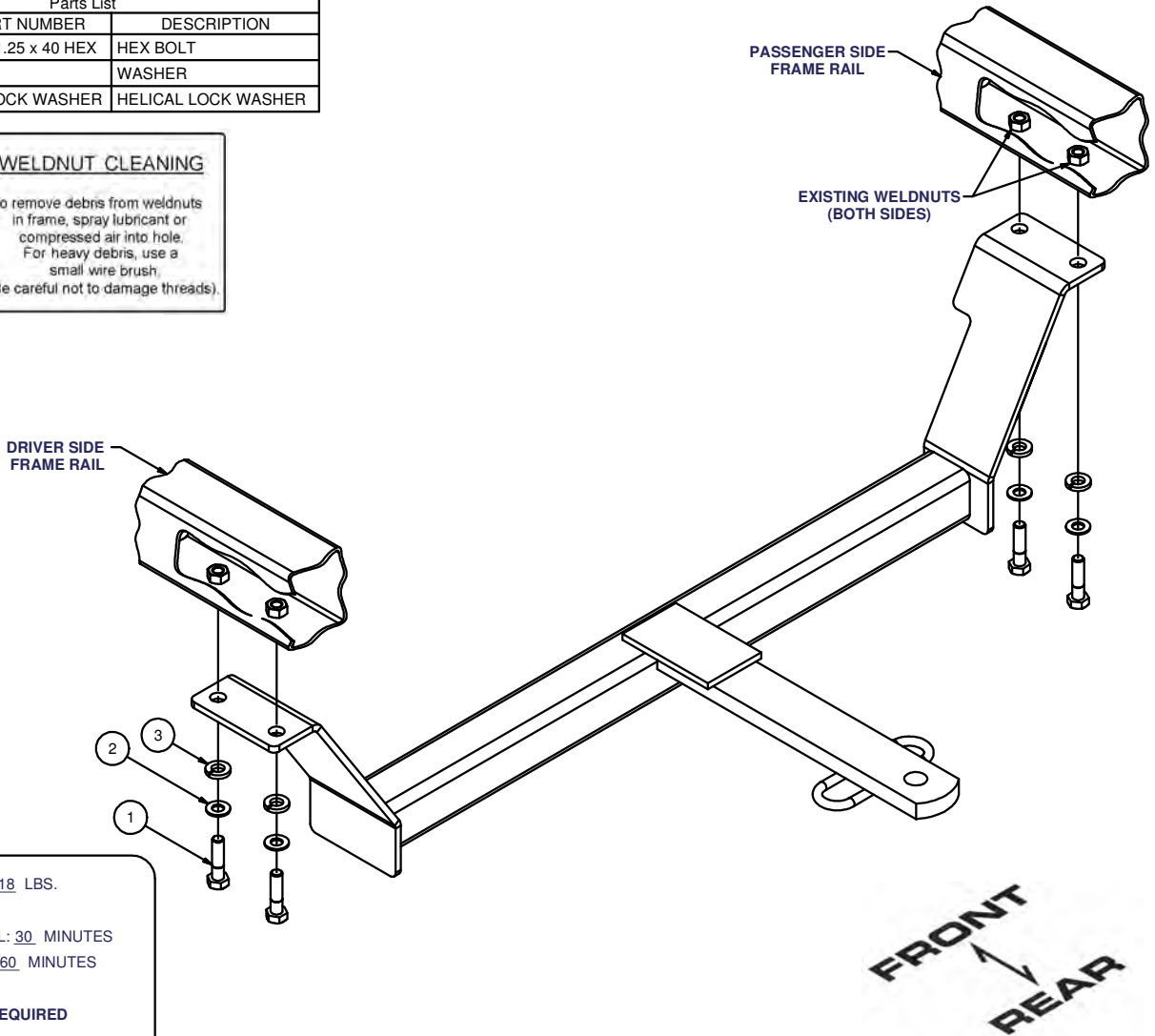
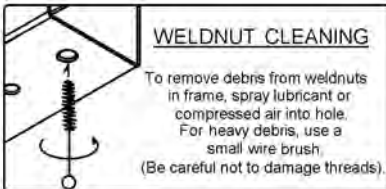

HITCH WEIGHT: 18 LBS.

INSTALL TIME

PROFESSIONAL: 30 MINUTES

NOVICE (DIY): 60 MINUTES

INSTALL NOTES:**-NO DRILLING REQUIRED****INSTALLATION STEPS**

- This hitch mounts directly to the vehicle's frame rails in (2) places on each side at existing weldnuts. The weldnuts are at the rear most point on the frame rails, just forward of the lower trim panel under the bumper.
 - COLT notchback (trunk lid): The weldnuts are unused and the hitch can be bolted directly to the frame rails.
 - COLT and MIRAGE Hatchback: Tie down brackets are bolted on each side and must be removed for hitch installation.
- Bolt the hitch to the vehicle's frame using supplied fasteners as shown
- Torque all 10mm fasteners to 48 lb-ft.

PERIODICALLY CHECK THIS RECEIVER HITCH TO ENSURE THAT ALL FASTENERS ARE TIGHT AND THAT ALL STRUCTURAL COMPONENTS ARE SOUND.

Curt Manufacturing Inc., warrants this product to be free of defects in material and/or workmanship at the time of retail purchase by the original purchaser. If the product is found to be defective, Curt Manufacturing Inc., may repair or replace the product, at their option, when the product is returned, prepaid, with proof of purchase. Alteration to, misuse of, or improper installation of this product voids the warranty. Curt Manufacturing Inc.'s liability is limited to repair or replacement of products found to be defective, and specifically excludes liability for incidental or consequential loss or damage.