

11536

85-88 NISSAN MAXIMA WAGON

12/14/2012

GROSS LOAD CAPACITY WHEN USED AS A WEIGHT CARRYING HITCH: 1,500 LBS. TRAILER WEIGHT & 150 LBS. TONGUE WEIGHT.

DO NOT EXCEED VEHICLE MANUFACTURER'S RECOMMENDED TOWING CAPACITY.

WARNING: ALL NON-TRAILER LOADS APPLIED TO THIS PRODUCT MUST BE SUPPORTED BY 18050 STABILIZING STRAPS.

** FAILURE TO PROPERLY SUPPORT NON-TRAILER LOADS WILL VOID PRODUCT WARRANTY**

HAVING INSTALLATION QUESTIONS? CALL TECHNICAL SUPPORT AT 1-800-798-0813

Parts List			
ITEM	QTY	PART NUMBER	DESCRIPTION
1	4	3/8"	LOCK WASHER
2	4	3/8 - 16	HEX NUT
3	4	3/8-16 X 1 1/2	HEX BOLT
4	4	3/8"	FENDER WASHER
5	2	7/16-14 x 1 1/2	CARRIAGE BOLT
6	2	CM-SP2	.250 x .88 x 2.25" SQUARE HOLE SPACER
7	2	7/16 LOCK WASHER	HELICAL LOCK WASHER
8	2	7/16-14	HEX NUT
9	2	7_16 FISHWIRE	7/16" FISHWIRE

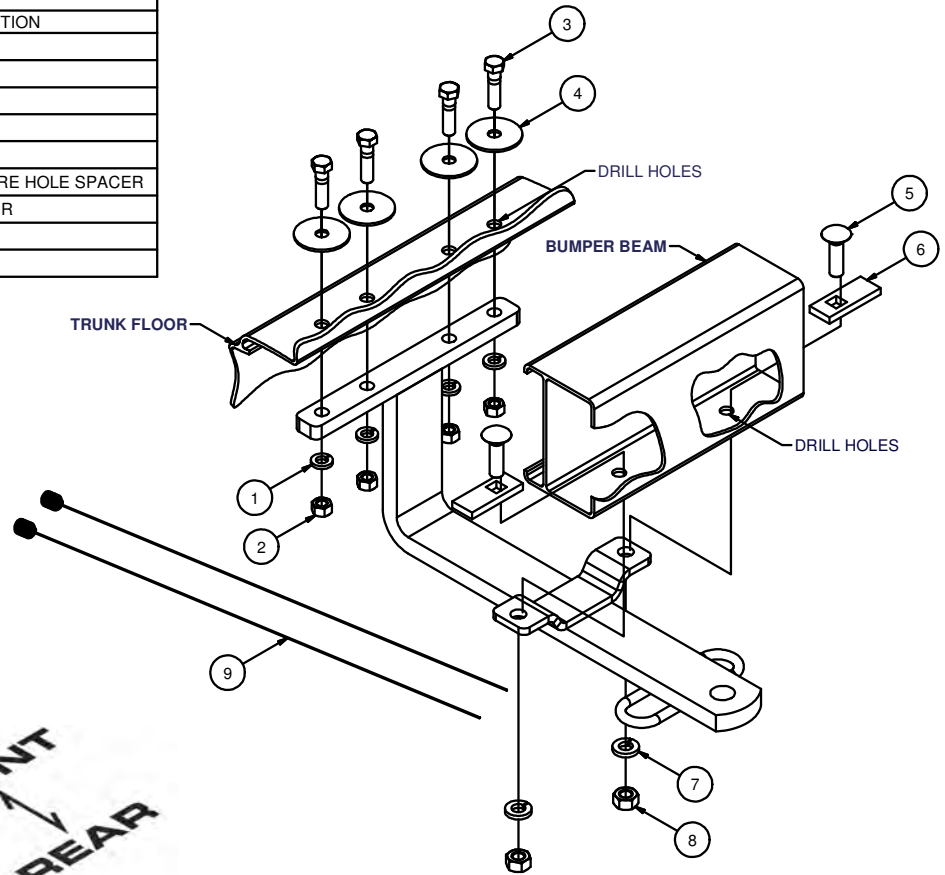
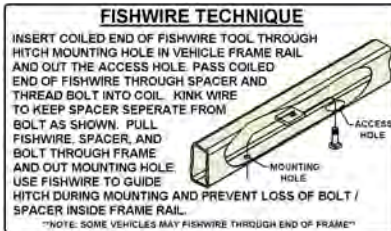

HITCH WEIGHT: 9 LBS.

INSTALL TIME

PROFESSIONAL: 45 MINUTES

NOVICE (DIY): 90 MINUTES

INSTALL NOTES:

- DRILLING REQUIRED
- TRIM BUMPER FASCIA
- SILICONE SEAL HARDWARE
- CLEAR TRUNK

INSTALLATION STEPS

1. Hold the hitch in place against the underside of the trunk floor and the rear bumper centered and square with the vehicle. Remove any material from the bumper that prevents the hitch from fitting flush with the metal bumper. Hitch tongue must extend past the bumper for hitch ball clearance. Using the hitch as a template, mark the underside of the floor and steel bumper for hitch mounting holes.
2. Clear inside trunk before drilling floor holes. Drill holes in floor 13/32" diameter, and holes in bumper 7/16" diameter.
3. If necessary, drill (1) 1" diameter or larger access hole in bumper. Fishwire 7/16" carriage bolts and CM-SP2 spacers into bumper beam as shown.(See FISHWIRE TECHNIQUE diagram) Position the hitch over these fasteners and mount the hitch to vehicle as shown.
4. Install 3/8" fasteners in trunk floor with fender washers installed on the inside of the trunk floor.
5. Torque all 3/8" fasteners to 45 lb-ft, and all 7/16" fasteners to 70 lb-ft.
6. Use silicone sealant to seal hardware installed through trunk floor.
7. Reinstall contents removed from trunk in Step 2.

PERIODICALLY CHECK THIS RECEIVER HITCH TO ENSURE THAT ALL FASTENERS ARE TIGHT AND THAT ALL STRUCTURAL COMPONENTS ARE SOUND.

Curt Manufacturing Inc., warrants this product to be free of defects in material and/or workmanship at the time of retail purchase by the original purchaser. If the product is found to be defective, Curt Manufacturing Inc., may repair or replace the product, at their option, when the product is returned, prepaid, with proof of purchase. Alteration to, misuse of, or improper installation of this product voids the warranty. Curt Manufacturing Inc.'s liability is limited to repair or replacement of products found to be defective, and specifically excludes liability for incidental or consequential loss or damage.