

11561

86-88 VOLKSWAGEN QUANTUM WAGON

12/17/2012

GROSS LOAD CAPACITY WHEN USED AS A WEIGHT CARRYING HITCH: 1,500 LBS. TRAILER WEIGHT & 150 LBS. TONGUE WEIGHT.

DO NOT EXCEED VEHICLE MANUFACTURER'S RECOMMENDED TOWING CAPACITY.

WARNING: ALL NON-TRAILER LOADS APPLIED TO THIS PRODUCT MUST BE SUPPORTED BY 18050 STABILIZING STRAPS.

** FAILURE TO PROPERLY SUPPORT NON-TRAILER LOADS WILL VOID PRODUCT WARRANTY**

HAVING INSTALLATION QUESTIONS? CALL TECHNICAL SUPPORT AT 1-800-798-0813

Parts List			
ITEM	QTY	PART NUMBER	DESCRIPTION
1	6	HFN3816	HEX FLANGE NUT
2	6	3/8 - 16 x 1 1/4	HEX BOLT
3	4	3/8"	FENDER WASHER

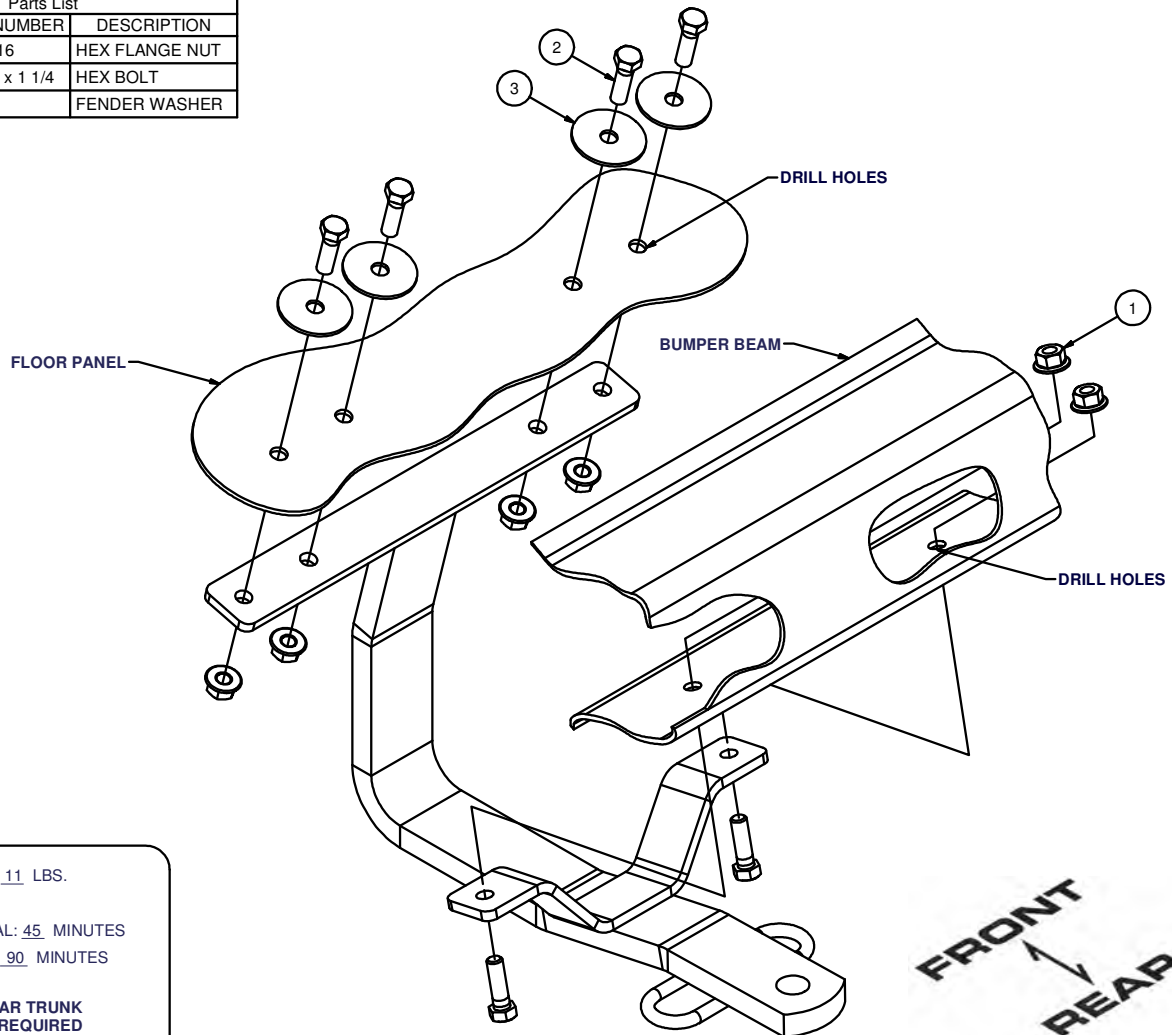

HITCH WEIGHT: 11 LBS.

INSTALL TIME

PROFESSIONAL: 45 MINUTES

NOVICE (DIY): 90 MINUTES

INSTALL NOTES:

- TEMP CLEAR TRUNK
- DRILLING REQUIRED
- SILICONE HARDWARE
- TRIM BUMPER FASCIA

INSTALLATION STEPS

1. Clear the trunk of all contents for drilling. Position the hitch against the floor panel and bumper centered and square with the vehicle. Trim bumper fascia where the hitch bracket makes contact. The hitch must attach directly to the metal bumper. Using the hitch as a template, mark and drill (4) places in the floor panel and (2) places in the bottom of the bumper for 3/8" bolts.
2. Bolt the hitch to the trunk pan and bumper using fasteners as shown. Fender washers MUST be installed at the floor panel OPPOSITE the hitch.
3. Torque all 3/8" fastener to 45 lb-ft.
4. Use silicone sealant around fasteners installed in the trunk to seal out water and exhaust fumes.
5. Reinstall trunk contents removed in step 1.

PERIODICALLY CHECK THIS RECEIVER HITCH TO ENSURE THAT ALL FASTENERS ARE TIGHT AND THAT ALL STRUCTURAL COMPONENTS ARE SOUND.

Curt Manufacturing Inc., warrants this product to be free of defects in material and/or workmanship at the time of retail purchase by the original purchaser. If the product is found to be defective, Curt Manufacturing Inc., may repair or replace the product, at their option, when the product is returned, prepaid, with proof of purchase. Alteration to, misuse of, or improper installation of this product voids the warranty. Curt Manufacturing Inc.'s liability is limited to repair or replacement of products found to be defective, and specifically excludes liability for incidental or consequential loss or damage.

217267