

11598

90-94 MAZDA 323 HATCHBACK

12/14/2012

GROSS LOAD CAPACITY WHEN USED AS A WEIGHT CARRYING HITCH: 1,000 LBS. TRAILER WEIGHT & 100 LBS. TONGUE WEIGHT.

*****DO NOT EXCEED VEHICLE MANUFACTURER'S RECOMMENDED TOWING CAPACITY.*****

WARNING: ALL NON-TRAILER LOADS APPLIED TO THIS PRODUCT MUST BE SUPPORTED BY 18050 STABILIZING STRAPS.

**** FAILURE TO PROPERLY SUPPORT NON-TRAILER LOADS WILL VOID PRODUCT WARRANTY****

HAVING INSTALLATION QUESTIONS? CALL TECHNICAL SUPPORT AT 1-800-798-0813

Parts List			
ITEM	QTY	PART NUMBER	DESCRIPTION
1	2	3/8-16 X 1 1/2	HEX BOLT
2	2	3/8 - 16	HEX NUT
3	2	3/8"	LOCK WASHER
4	2	5/8 - 11 x 2 HEX	HEX BOLT
5	2	5/8-11	HEX FLANGE NUT
6	2	3/8"	FENDER WASHER

**RUBBER ISOLATOR
REMOVAL DIAGRAM**

This technique can be used if and Exhaust Hanger Removal Pliers is not available.

Using a 5/8" open end wrench, slide the wrench up to the rubber isolator, cradling the hanger rod as shown. Next place the flat edge of a pry bar between the wrench and the hanger stop or hanger rod. Then simply rotate the pry bar toward the wrench to remove the rubber isolator.

Note: Using a spray lubricant or soapy water on the hanger rod and the rubber isolator helps removal.

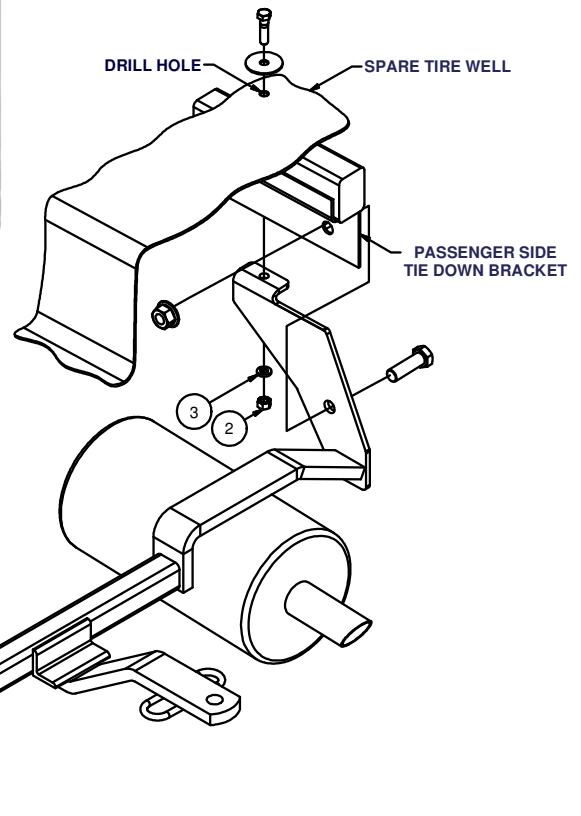
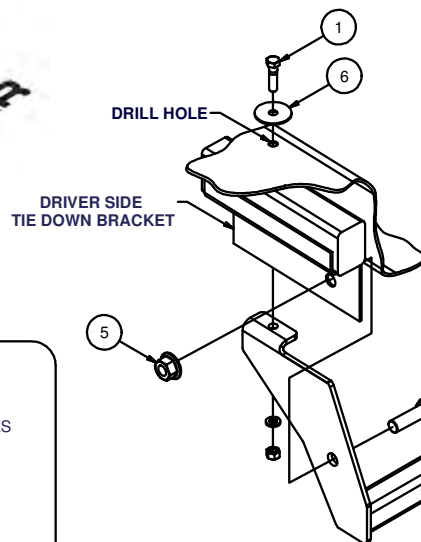
FRONT
↑
REAR

HITCH WEIGHT: 24 LBS.

INSTALL TIME

PROFESSIONAL: 45 MINUTES

NOVICE (DIY): 90 MINUTES

INSTALL NOTES:

- LOWER EXHAUST
- DRILLING REQUIRED
- CLEAR SPARE TIRE WELL
- SILICONE SEAL HARDWARE

INSTALLATION STEPS

1. Under the rear of the vehicle, locate the tie down brackets (vertical plates with slots) joined to the driver and passenger side frame rails.
2. Work the hitch into position over the exhaust extension (inside the driver side tie down bracket) and outside of the passenger side tie down bracket. To ease installation, it may be necessary to temporarily release the rear exhaust hangers. Install fasteners into tie down brackets as shown, and adjust the hitch so that the tabs on the hitch side plates fit flush against the vehicle spare tire well.
3. After clearing the inside of the spare tire well, use the hitch as a template to drill (2) holes for 3/8" diameter bolts through the spare tire well floor. It may be necessary to mark the holes and lower the hitch to drill the holes.
4. Install the fasteners as shown. Be certain to use fender washers inside the vehicle opposite the hitch. Make certain the hitch is fitting flush at the vehicle spare tire well and tighten all fasteners.
5. Torque all 3/8" fasteners to 45 lb-ft, and all 5/8" fasteners to 210 lb-ft.
6. Use silicone sealant to seal hardware installed through spare tire well.
7. Reinstall contents removed from spare tire well in Step 3.

PERIODICALLY CHECK THIS RECEIVER HITCH TO ENSURE THAT ALL FASTENERS ARE TIGHT AND THAT ALL STRUCTURAL COMPONENTS ARE SOUND.

Curt Manufacturing Inc., warrants this product to be free of defects in material and/or workmanship at the time of retail purchase by the original purchaser. If the product is found to be defective, Curt Manufacturing Inc., may repair or replace the product, at their option, when the product is returned, prepaid, with proof of purchase. Alteration to, misuse of, or improper installation of this product voids the warranty. Curt Manufacturing Inc.'s liability is limited to repair or replacement of products found to be defective, and specifically excludes liability for incidental or consequential loss or damage.

217314