

11618**80-88 PEUGEOT 505 SEDAN**

12/17/2012

GROSS LOAD CAPACITY WHEN USED AS A WEIGHT CARRYING HITCH: 1,500 LBS. TRAILER WEIGHT & 150 LBS. TONGUE WEIGHT.

*****DO NOT EXCEED VEHICLE MANUFACTURER'S RECOMMENDED TOWING CAPACITY.*****

WARNING: ALL NON-TRAILER LOADS APPLIED TO THIS PRODUCT MUST BE SUPPORTED BY 18050 STABILIZING STRAPS.

**** FAILURE TO PROPERLY SUPPORT NON-TRAILER LOADS WILL VOID PRODUCT WARRANTY****

HAVING INSTALLATION QUESTIONS? CALL TECHNICAL SUPPORT AT 1-800-798-0813

Parts List			
ITEM	QTY	PART NUMBER	DESCRIPTION
1	2	3_8 - 16 x 3.75 x 2.50 C-C U-BOLT	U-BOLT
2	9	HFN3816	HEX FLANGE NUT
3	3	3/8 - 16 x 1 1/4	HEX BOLT
4	3	3/8"	FENDER WASHER
5	2	3/8-16 X 1 1/2	HEX BOLT
6	1	CM-11618-TB	.50 x 1.25 TAIL BRACKET

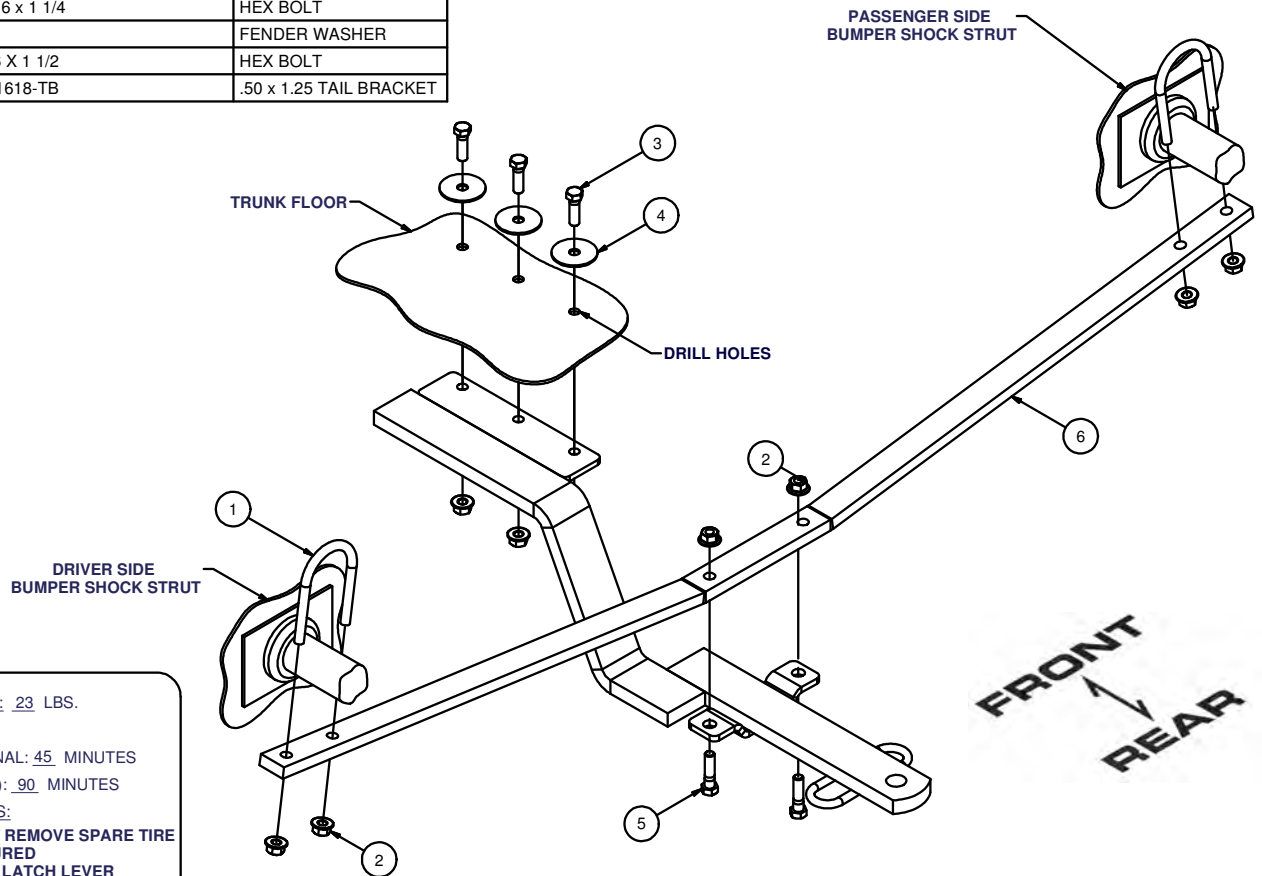

HITCH WEIGHT: 23 LBS.

INSTALL TIME

PROFESSIONAL: 45 MINUTES

NOVICE (DIY): 90 MINUTES

INSTALL NOTES:

- CLEAR TRUNK / REMOVE SPARE TIRE
- DRILLING REQUIRED
- MODIFY SPARE LATCH LEVER
- SILICONE HARDWARE

INSTALLATION STEPS

1. Lift any floor covering inside the truck and remove the spare tire.
2. Fasten the CM-11618-TB to the tongue bracket using fasteners as shown. Position the hitch assembly under the bumper shock struts and the trunk floor. Loosely fasten the CM-11618-TB to the shock struts using U-bolts as shown.
3. Locate the hitch assembly to allow enough hitch ball/bumper clearance and permits the spare tire bracket to swing up onto the lock without hitting the hitch. Spare tire latch lever may have to be bent slightly for hitch clearance. Using the hitch as a template, drill the truck floor for 3/8" fasteners. Fasten the hitch to the vehicle as shown.
4. Torque all 3/8" fasteners to 45 lb-ft. Do not use impact wrench on U-bolts.
5. Apply silicone sealant around fasteners installed in the trunk to seal out water and exhaust fumes.
6. Reinstall spare tire and floor coverings removed in step 1.

PERIODICALLY CHECK THIS RECEIVER HITCH TO ENSURE THAT ALL FASTENERS ARE TIGHT AND THAT ALL STRUCTURAL COMPONENTS ARE SOUND.

Curt Manufacturing Inc., warrants this product to be free of defects in material and/or workmanship at the time of retail purchase by the original purchaser. If the product is found to be defective, Curt Manufacturing Inc., may repair or replace the product, at their option, when the product is returned, prepaid, with proof of purchase. Alteration to, misuse of, or improper installation of this product voids the warranty. Curt Manufacturing Inc.'s liability is limited to repair or replacement of products found to be defective, and specifically excludes liability for incidental or consequential loss or damage.

217342