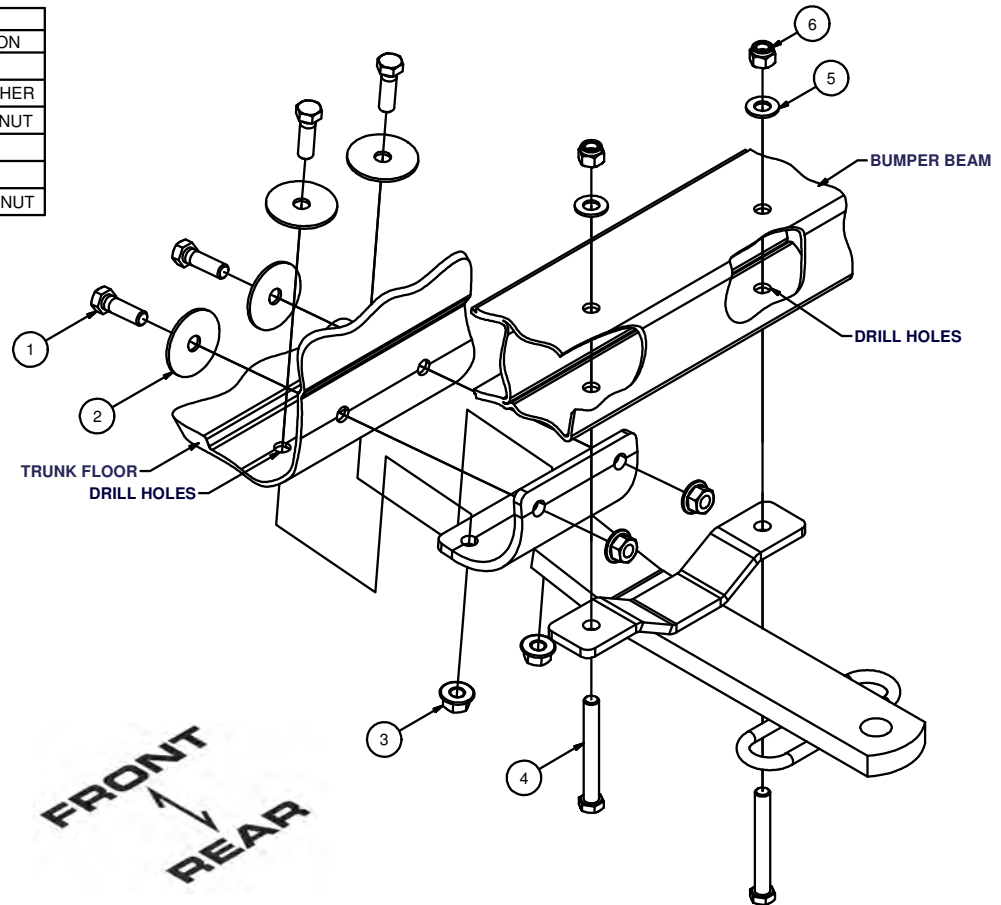

11639**87-91 SUBARU XT COUPE & XT6****3/25/2013****GROSS LOAD CAPACITY WHEN USED AS A WEIGHT CARRYING HITCH: 1,000 LBS. TRAILER WEIGHT & 100 LBS. TONGUE WEIGHT.*******DO NOT EXCEED VEHICLE MANUFACTURER'S RECOMMENDED TOWING CAPACITY.*******WARNING: ALL NON-TRAILER LOADS APPLIED TO THIS PRODUCT MUST BE SUPPORTED BY 18050 STABILIZING STRAPS.****** FAILURE TO PROPERLY SUPPORT NON-TRAILER LOADS WILL VOID PRODUCT WARRANTY******HAVING INSTALLATION QUESTIONS? CALL TECHNICAL SUPPORT AT 1-800-798-0813**

Parts List			
ITEM	QTY	PART NUMBER	DESCRIPTION
1	4	3/8 - 16 x 1 1/4	HEX BOLT
2	4	3/8"	FENDER WASHER
3	4	HFN3816	HEX FLANGE NUT
4	2	3/8-16 x 3	HEX BOLT
5	2	3/8"	WASHER
6	2	3/8-16	NYLOCK HEX NUT

**HITCH WEIGHT: 7 LBS.****INSTALL TIME**PROFESSIONAL: 45 MINUTESNOVICE (DIY): 90 MINUTES**INSTALL NOTES:**

- CLEAR TRUNK
- FASCIA TRIMMING REQUIRED
- DRILLING REQUIRED
- SILICONE HARDWARE

INSTALLATION STEPS

1. Remove any material in the trunk that could be damaged when drilling vehicle. Locate and mark the center point on the rear bumper.
2. Cut away the plastic retainer on the later models under the inner bumper for clearance for the hitch bumper bracket. The hitch bracket must fit directly onto the steel inner bumper. The hitch should fit on the vehicle centered and level.
3. Using the hitch as a template, mark and centerpunch the inner bumper and body panel for (6) bolts. Drill vehicle (6) places for 3/8" diameter bolts. Note that the inner bumper requires drilling straight up through (2) surfaces. Drilling the upper holes may require drilling from the inside by centerpunching the outside.
4. Mount the hitch using fasteners as shown. Note that the fender washers should be positioned on the opposite side of the hitch, in the inside of the vehicle.
5. Torque all 3/8" fasteners to 45 lb-ft.
6. Use silicone sealant around fasteners installed in trunk pan to seal out water and exhaust fumes.
7. Reinstall trunk contents removed in step 1.

PERIODICALLY CHECK THIS RECEIVER HITCH TO ENSURE THAT ALL FASTENERS ARE TIGHT AND THAT ALL STRUCTURAL COMPONENTS ARE SOUND.

Curt Manufacturing Inc., warrants this product to be free of defects in material and/or workmanship at the time of retail purchase by the original purchaser. If the product is found to be defective, Curt Manufacturing Inc., may repair or replace the product, at their option, when the product is returned, prepaid, with proof of purchase. Alteration to, misuse of, or improper installation of this product voids the warranty. Curt Manufacturing Inc.'s liability is limited to repair or replacement of products found to be defective, and specifically excludes liability for incidental or consequential loss or damage.