

11641**82-85 TOYOTA CELICA COUPE**

12/14/2012

GROSS LOAD CAPACITY WHEN USED AS A WEIGHT CARRYING HITCH: 1,000 LBS. TRAILER WEIGHT & 100 LBS. TONGUE WEIGHT.

*****DO NOT EXCEED VEHICLE MANUFACTURER'S RECOMMENDED TOWING CAPACITY.*****

WARNING: ALL NON-TRAILER LOADS APPLIED TO THIS PRODUCT MUST BE SUPPORTED BY 18050 STABILIZING STRAPS.

**** FAILURE TO PROPERLY SUPPORT NON-TRAILER LOADS WILL VOID PRODUCT WARRANTY****

HAVING INSTALLATION QUESTIONS? CALL TECHNICAL SUPPORT AT 1-800-798-0813

Parts List			
ITEM	QTY	PART NUMBER	DESCRIPTION
1	2	3/8 - 16 x 1 1/4	HEX BOLT
2	1	1/2"	LOCK WASHER
3	2	HFN3816	HEX FLANGE NUT
4	1	1/2-13 x 1 3/4	HEX BOLT

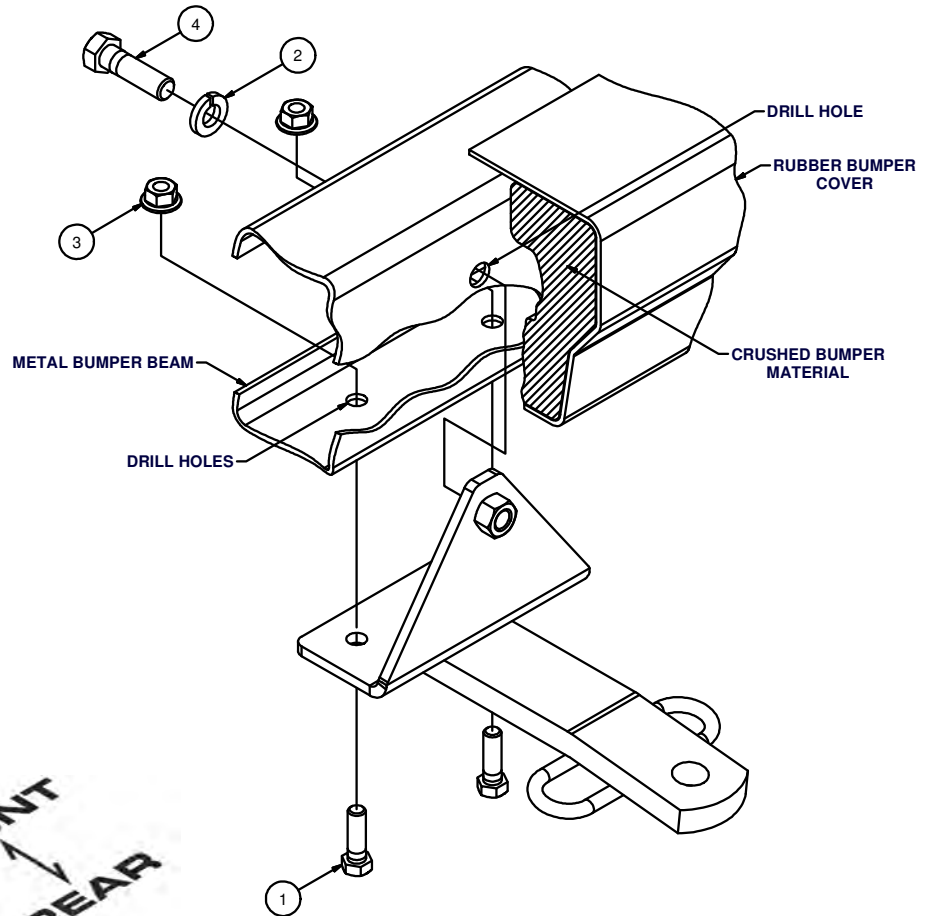

HITCH WEIGHT: 6 LBS.

INSTALL TIME

PROFESSIONAL: 45 MINUTES

NOVICE (DIY): 90 MINUTES

INSTALL NOTES:

- REMOVE REAR BUMPER
- FASCIA TRIMMING REQUIRED
- DRILLING REQUIRED

INSTALLATION STEPS

1. Remove the rear bumper by removing (4) to (6) screws located inside the trunk / hatch area or under the vehicle near the bumper bracket. Also check for small screws located at the ends of the bumper in the fender well and remove them.
2. Locate and remove the metal U-channel at the bottom of the rear bumper fastening the rubber cover to the bumper. A 6-7" piece must be removed from the center of this channel before it is reinstalled.
3. Trim the rubber bumper cover and crush the interior bumper material to allow the hitch bracket to fit directly on the steel part of the bumper centered across the vehicle.
4. Using the hitch as a template, mark the metal bumper beam for drilling. Drill (1) hole for 1/2" hardware through face of bumper beam and drill (2) holes for 3/8" hardware through bottom of the bumper beam.
5. Installed hardware as shown.
6. Torque all 3/8" fasteners to 45 lb-ft, and all 1/2" fasteners to 110 lb-ft.
7. Reinstall the rear bumper in reverse order.

PERIODICALLY CHECK THIS RECEIVER HITCH TO ENSURE THAT ALL FASTENERS ARE TIGHT AND THAT ALL STRUCTURAL COMPONENTS ARE SOUND.

Curt Manufacturing Inc., warrants this product to be free of defects in material and/or workmanship at the time of retail purchase by the original purchaser. If the product is found to be defective, Curt Manufacturing Inc., may repair or replace the product, at their option, when the product is returned, prepaid, with proof of purchase. Alteration to, misuse of, or improper installation of this product voids the warranty. Curt Manufacturing Inc.'s liability is limited to repair or replacement of products found to be defective, and specifically excludes liability for incidental or consequential loss or damage.