

11668**94-97 FORD ASPIRE, SEDAN**

12/7/2012

GROSS LOAD CAPACITY WHEN USED AS A WEIGHT CARRYING HITCH: 1,500 LBS. TRAILER WEIGHT & 150 LBS. TONGUE WEIGHT.

*****DO NOT EXCEED VEHICLE MANUFACTURER'S RECOMMENDED TOWING CAPACITY.*****

WARNING: ALL NON-TRAILER LOADS APPLIED TO THIS PRODUCT MUST BE SUPPORTED BY 18050 STABILIZING STRAPS.

**** FAILURE TO PROPERLY SUPPORT NON-TRAILER LOADS WILL VOID PRODUCT WARRANTY****

HAVING INSTALLATION QUESTIONS? CALL TECHNICAL SUPPORT AT 1-800-798-0813

Parts List			
ITEM	QTY	PART NUMBER	DESCRIPTION
1	4	3/8 - 16 x 1 1/4	HEX BOLT
2	4	3/8"	FENDER WASHER
3	6	3/8"	LOCK WASHER
4	6	3/8 - 16	HEX NUT
5	2	3/8"	WASHER
6	2	3/8-16 x 1 1/2	CARRIAGE BOLT
7	2	CM-SP18	.250 x 1.00 x 2.00" SQUARE HOLE SPACER
8	1	CM-375-FW	FISHWIRE TOOL

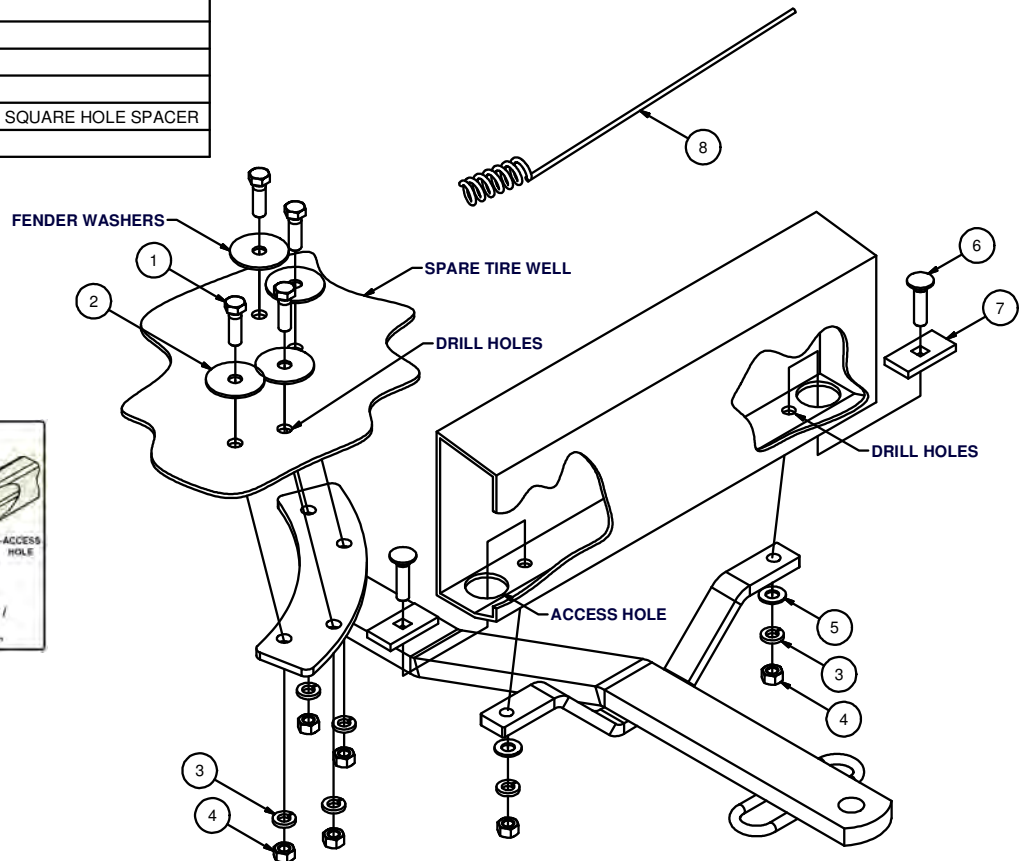
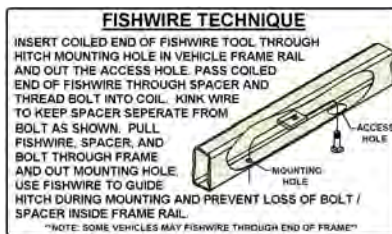
HITCH WEIGHT: 11 LBS.**INSTALL TIME**PROFESSIONAL: 30 MINUTESNOVICE (DIY): 60 MINUTES**INSTALL NOTES:**

- TEMP REMOVE SPARE, CLEAR TRUNK
- FISHWIRE FASTENERS
- DRILLING REQUIRED
- SILICONE AROUND FASTENERS

INSTALLATION STEPS

1. This hitch mounts to the bottom of the bumper and to the bottom of the spare tire well.
2. Remove spare tire. Clear tire well and trunk of contents. Center and square hitch on vehicle with bumper brackets against bumper and tail bracket on tire well. Using the hitch as a template, drill vehicle for 3/8" fasteners. Also drill 1" access holes on bottom of bumper for fishwiring fasteners into the bumper.
3. Fishwire fasteners into position as shown.
4. Using hitch as a template, drill the tire well for 3/8" fasteners. Install fasteners as shown. Note that the fender washers go inside the tire well.
5. Torque all 3/8" fasteners 45 lb-ft.
6. Use silicone sealant around fasteners to seal out water and exhaust vapors.
7. Reinstall spare tire and trunk contents.

PERIODICALLY CHECK THIS RECEIVER HITCH TO ENSURE THAT ALL FASTENERS ARE TIGHT AND THAT ALL STRUCTURAL COMPONENTS ARE SOUND.

Curt Manufacturing Inc., warrants this product to be free of defects in material and/or workmanship at the time of retail purchase by the original purchaser. If the product is found to be defective, Curt Manufacturing Inc., may repair or replace the product, at their option, when the product is returned, prepaid, with proof of purchase. Alteration to, misuse of, or improper installation of this product voids the warranty. Curt Manufacturing Inc.'s liability is limited to repair or replacement of products found to be defective, and specifically excludes liability for incidental or consequential loss or damage.