

GROSS LOAD CAPACITY WHEN USED AS A WEIGHT CARRYING HITCH: 2,000 LBS. TRAILER WEIGHT & 200 LBS. TONGUE WEIGHT.

*****DO NOT EXCEED VEHICLE MANUFACTURER'S RECOMMENDED TOWING CAPACITY.*****

WARNING: ALL NON-TRAILER LOADS APPLIED TO THIS PRODUCT MUST BE SUPPORTED BY AUXILIARY STABILIZING STRAPS.

**** FAILURE TO PROPERLY SUPPORT NON-TRAILER LOADS WILL VOID PRODUCT WARRANTY****

HAVING INSTALLATION QUESTIONS? CALL TECHNICAL SUPPORT AT 1-800-798-0813

| Parts List | | | |
|------------|-----|----------------|--|
| ITEM | QTY | PART NUMBER | DESCRIPTION |
| 1 | 8 | HFN 1213 | HEX FLANGE NUT |
| 2 | 3 | 1/2-13 x 1 | CARRIAGE BOLT |
| 3 | 4 | CM-SP6 | .250 x 1.00 x 3.00" SQUARE HOLE SPACER |
| 4 | 1 | CM-SP12 | .250 x 1.00 x 2.00" SQUARE HOLE SPACER |
| 5 | 5 | 1/2-13 x 1 1/2 | CARRIAGE BOLT |
| 6 | 1 | 1/2" | FISHWIRE TOOL |

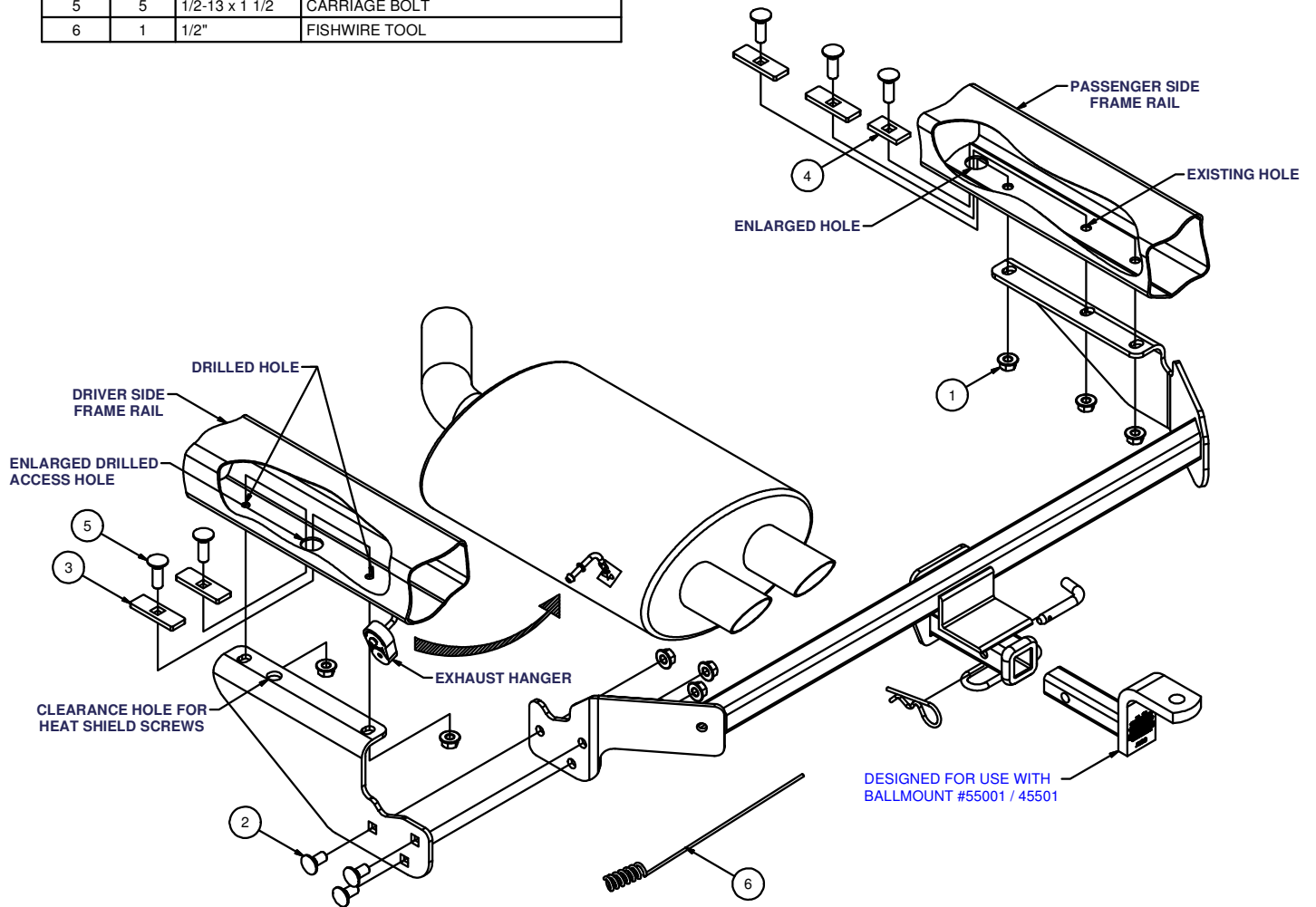

HITCH WEIGHT: 34 LBS.

INSTALL TIME

PROFESSIONAL: 90 MINUTES

NOVICE (DIY): 180 MINUTES

INSTALL NOTES:

- DRILLING REQUIRED
- LOWER EXHAUST
- REMOVE HEAT SHIELD
- ENLARGE HOLE
- FISHWIRE HARDWARE

FRONT
↑
REAR

PERIODICALLY CHECK THIS RECEIVER HITCH TO ENSURE THAT ALL FASTENERS ARE TIGHT AND THAT ALL STRUCTURAL COMPONENTS ARE SOUND.

Curt Manufacturing Inc., warrants this product to be free of defects in material and/or workmanship at the time of retail purchase by the original purchaser. If the product is found to be defective, Curt Manufacturing Inc., may repair or replace the product, at their option, when the product is returned, prepaid, with proof of purchase. Alteration to, misuse of, or improper installation of this product voids the warranty. Curt Manufacturing Inc.'s liability is limited to repair or replacement of products found to be defective, and specifically excludes liability for incidental or consequential loss or damage.

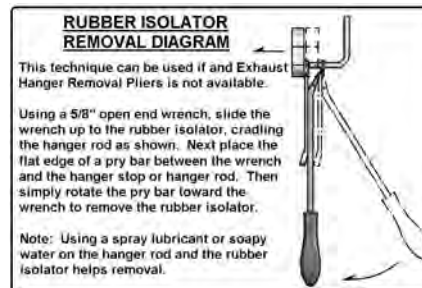
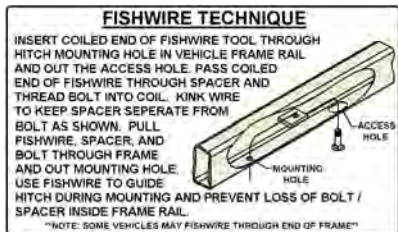

INSTALLATION STEPS

1. Lower three (3) exhaust hangers and remove heat shield.
2. Enlarge forward most hole on passenger side frame rail (1 1/8") for fishwire access. Fishwire carriage bolt and spacer into existing hole on the passenger side as shown.
3. Lift the passenger side of the hitch into position; centered and square on the car. Loosely attach the passenger side of the hitch. Using the hitch as a template, mark and drill the vehicle's frame rail two (2) places for fasteners as shown.
4. Hold the supplied driver side plate to the frame. Raise the driver side of the hitch into position and loosely fasten to driver side plate. Using the plate as a template; mark and drill two (2) holes in the frame rail. Lower the hitch assembly.
5. Push the exhaust towards the center of the vehicle to drill driver side mounting holes and access hole (1 1/8") as shown. Fishwire all remaining carriage bolts and spacers into position, making sure the short spacer is installed in the rear-most hole on passenger side.
6. Trim the heat shield to provide clearance for driver side plate and refit it onto the vehicle.
7. Raise driver side plate into position and secure using forward most hole first.
(**Note:** exhaust hanger bracket must be above plate before installing)
8. Reinstall passenger side of hitch and torque both parts together. Torque all 1/2" fasteners to 110 lb-ft.

PERIODICALLY CHECK THIS RECEIVER HITCH TO ENSURE THAT ALL FASTENERS ARE TIGHT AND THAT ALL STRUCTURAL COMPONENTS ARE SOUND.