

11708

92-95 MAZDA MX-3

12/14/2012

GROSS LOAD CAPACITY WHEN USED AS A WEIGHT CARRYING HITCH: 2,000 LBS. TRAILER WEIGHT & 200 LBS. TONGUE WEIGHT.

\*\*\*DO NOT EXCEED VEHICLE MANUFACTURER'S RECOMMENDED TOWING CAPACITY.\*\*\*

WARNING: ALL NON-TRAILER LOADS APPLIED TO THIS PRODUCT MUST BE SUPPORTED BY 18050 STABILIZING STRAPS.

\*\* FAILURE TO PROPERLY SUPPORT NON-TRAILER LOADS WILL VOID PRODUCT WARRANTY\*\*

HAVING INSTALLATION QUESTIONS? CALL TECHNICAL SUPPORT AT 1-800-798-0813

Parts List			
ITEM	QTY	PART NUMBER	DESCRIPTION
1	2	3/8-16 x 1 1/2	HEX BOLT
2	2	3/8"	LOCK WASHER
3	2	3/8 - 16	HEX NUT
4	2	5_8 - 11 x 2 HEX	HEX TAP BOLT
5	2	5/8	WASHER
6	2	5_8 LOCK WASHER	5/8" HELICAL LOCK WASHER
7	2	5_8 - 11 HEX-NUT	5/8" 11 UNC HEX NUT
8	2	CM-SP102	.25 x 1.75 x 2.00 SPACER

TOOLS REQUIRED
DRILL
3/8" DRILL BIT
RATCHET
10" EXTENSION
9/16" SOCKET
15/16" SOCKET
15/16" WRENCH
TORQUE WRENCH

**RUBBER ISOLATOR REMOVAL DIAGRAM**

This technique can be used if and Exhaust Hanger Removal Pliers is not available.

Using a 5/8" open end wrench, slide the wrench up to the rubber isolator, cradling the hanger rod as shown. Next place the flat edge of a pry bar between the wrench and the hanger stop or hanger rod. Then simply rotate the pry bar toward the wrench to remove the rubber isolator.

Note: Using a spray lubricant or soapy water on the hanger rod and the rubber isolator helps removal.

HITCH WEIGHT: 25 LBS.

INSTALL TIME

PROFESSIONAL: 45 MINUTES

NOVICE (DIY): 90 MINUTES

INSTALL NOTES:

- LOWER EXHAUST
- DRILLING REQUIRED
- CLEAR TRUNK OF CONTENTS
- SILICONE FASTENERS

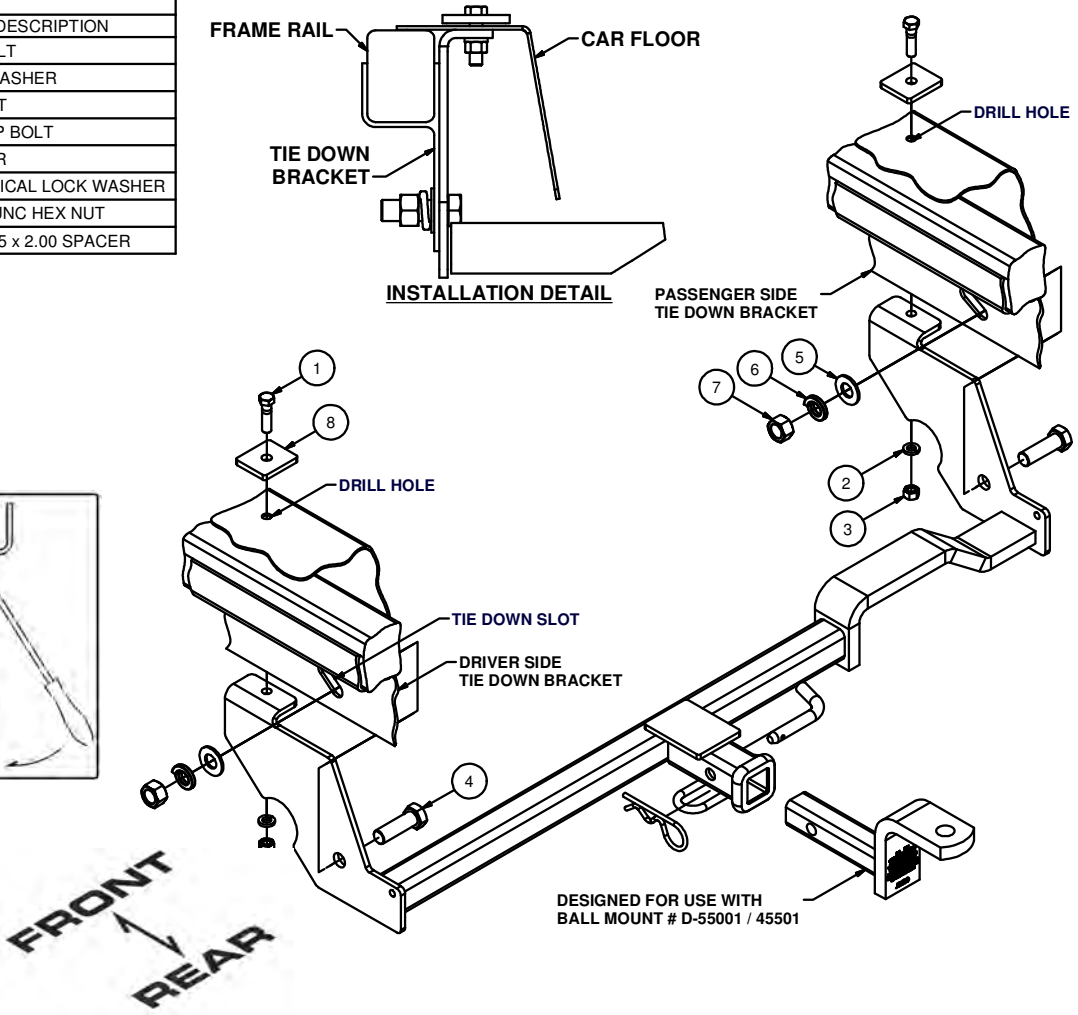

**INSTALLATION STEPS**

1. Under the rear of the vehicle, locate the tie down bracket (vertical bracket with slot) joined to the driver and passenger side frame rails.
2. Lower the exhaust for ease of installation. (See Rubber Isolator Removal Diagram) Work the hitch into position on the vehicle; over the exhaust extension, inside the driver side tie down bracket, and outside the passenger side tie down bracket. Install the 5/8" fasteners as shown and adjust the hitch in the tie down slots until the tabs on the side plates fit flush against the vehicle floor.
3. After clearing the inside of the vehicle where holes will be, drill holes for the 3/8" fasteners through the floor. It may be necessary to mark the holes and lower the hitch to drill these holes.
4. Install the 3/8" fasteners as shown. Be certain to use spacers under the 3/8" bolt heads inside the vehicle. Make certain the hitch fits flush with the vehicle floor.
5. Torque all 3/8" fasteners to 45 lb-ft, and all 5/8" fasteners to 210 lb-ft.
6. Use silicone caulk around fasteners to seal out water and exhaust fumes.

**PERIODICALLY CHECK THIS RECEIVER HITCH TO ENSURE THAT ALL FASTENERS ARE TIGHT AND THAT ALL STRUCTURAL COMPONENTS ARE SOUND.**

Curt Manufacturing Inc., warrants this product to be free of defects in material and/or workmanship at the time of retail purchase by the original purchaser. If the product is found to be defective, Curt Manufacturing Inc., may repair or replace the product, at their option, when the product is returned, prepaid, with proof of purchase. Alteration to, misuse of, or improper installation of this product voids the warranty. Curt Manufacturing Inc.'s liability is limited to repair or replacement of products found to be defective, and specifically excludes liability for incidental or consequential loss or damage.