

11717

90-94 VOLKSWAGEN PASSAT

12/14/2012

GROSS LOAD CAPACITY WHEN USED AS A WEIGHT CARRYING HITCH: 2,000 LBS. TRAILER WEIGHT & 200 LBS. TONGUE WEIGHT.

DO NOT EXCEED VEHICLE MANUFACTURER'S RECOMMENDED TOWING CAPACITY.

WARNING: ALL NON-TRAILER LOADS APPLIED TO THIS PRODUCT MUST BE SUPPORTED BY 18050 STABILIZING STRAPS.

** FAILURE TO PROPERLY SUPPORT NON-TRAILER LOADS WILL VOID PRODUCT WARRANTY**

HAVING INSTALLATION QUESTIONS? CALL TECHNICAL SUPPORT AT 1-800-798-0813

Parts List			
ITEM	QTY	PART NUMBER	DESCRIPTION
1	4	M10 - 1.5 x 30 HEX	HEX BOLT
2	4	7/16 LOCK WASHER	HELICAL LOCK WASHER
3	4	3/8-16 X 1 1/2	HEX BOLT
4	4	3/8"	LOCK WASHER
5	4	3/8 - 16	HEX NUT

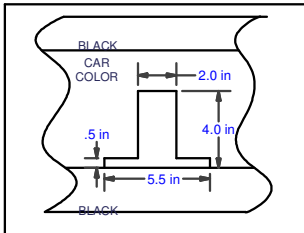
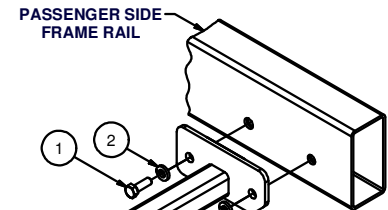
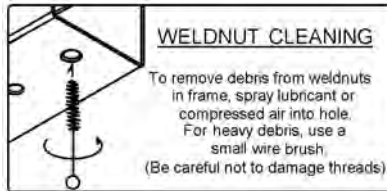

FASCIA CUT OUT
REAR BUMPER FASCIA
AS VIEWED FROM THE REAR

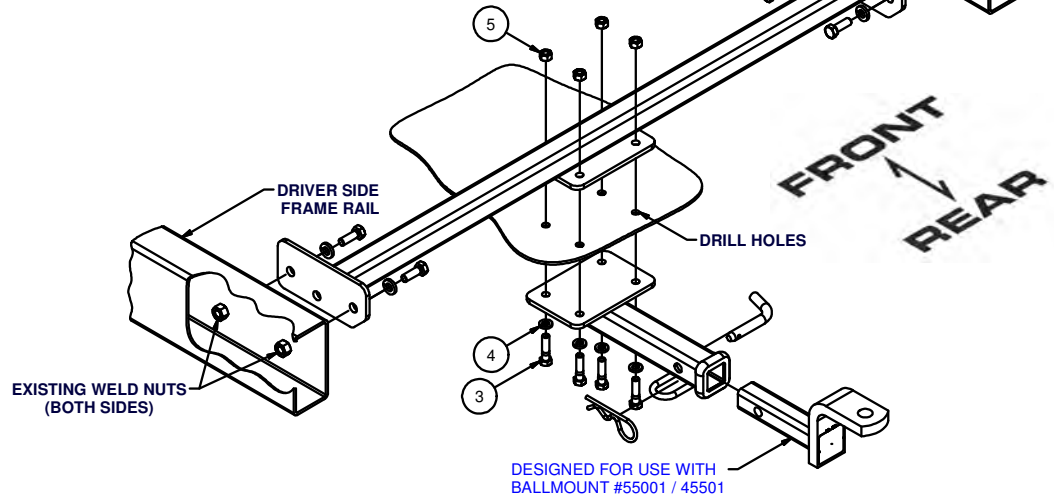

HITCH WEIGHT: 23 LBS.

INSTALL TIME

PROFESSIONAL: 45 MINUTES

NOVICE (DIY): 90 MINUTES

INSTALL NOTES:

- FASCIA TRIMMING REQUIRED
- DRILLING REQUIRED
- REMOVE LARGE UNDERBODY PANEL
- SILICONE HARDWARE

INSTALLATION STEPS

1. The tubular hitch assembly with welded ends and floor plate mounts INSIDE the vehicle's trunk compartment. The receiver assembly mounts outside and under the trunk area, bolting to the floor plate. First, lift the floor panel in the trunk for access to the floor area behind the spare tire.
2. Locate and remove (4) (2 per side) 10mm bolts at the driver and passenger frame rails fastening the rear bumper brackets inside the frame rails.
3. Install the hitch tubular assembly into the trunk area between the frame rails, with the center plate against the trunk floor. Bolt in place where bolts were just removed in the frame rails. Drill the vehicle's floor using the hitch as a template for 3/8" bolts.
4. Measure and mark the vehicle's rear bumper for center point across the vehicle. This center should match the center of the hitch floor plate inside the trunk. Refer to FASCIA CUT OUT diagram and use a utility knife to trim as shown. This cut out is made in the color part of the fascia, just above the black.
5. Temporarily remove the large panel under the vehicle, just forward of the rear bumper fascia. Position the hitch receiver assembly under the vehicle's floor so the receiver tube passes through the opening cut in the fascia, and the receiver plate aligns with the floor plate in the trunk. Fasten plates together as shown.
6. Torque all 3/8" fasteners to 45 lb-ft, and all 10mm fasteners to 45 lb-ft.
7. Apply silicone sealant around fasteners installed in trunk pan to seal out water and exhaust fumes.
8. Reinstall the large panel under the vehicle removed in step 5.

PERIODICALLY CHECK THIS RECEIVER HITCH TO ENSURE THAT ALL FASTENERS ARE TIGHT AND THAT ALL STRUCTURAL COMPONENTS ARE SOUND.

Curt Manufacturing Inc., warrants this product to be free of defects in material and/or workmanship at the time of retail purchase by the original purchaser. If the product is found to be defective, Curt Manufacturing Inc., may repair or replace the product, at their option, when the product is returned, prepaid, with proof of purchase. Alteration to, misuse of, or improper installation of this product voids the warranty. Curt Manufacturing Inc.'s liability is limited to repair or replacement of products found to be defective, and specifically excludes liability for incidental or consequential loss or damage.