

11732**95-96 VOLKSWAGEN CABRIO**

12/7/2012

GROSS LOAD CAPACITY WHEN USED AS A WEIGHT CARRYING HITCH: 2,000 LBS. TRAILER WEIGHT & 200 LBS. TONGUE WEIGHT.

*****DO NOT EXCEED VEHICLE MANUFACTURER'S RECOMMENDED TOWING CAPACITY.*******WARNING: ALL NON-TRAILER LOADS APPLIED TO THIS PRODUCT MUST BE SUPPORTED BY AUXILIARY STABILIZING STRAPS.****** FAILURE TO PROPERLY SUPPORT NON-TRAILER LOADS WILL VOID PRODUCT WARRANTY****

HAVING INSTALLATION QUESTIONS? CALL TECHNICAL SUPPORT AT 1-800-798-0813

Parts List			
ITEM	QTY	PART NUMBER	DESCRIPTION
1	2	7_16 - 14 x 4	HEX BOLT
2	5	7/16 WASHER	WASHER
3	4	7/16 LOCK WASHER	HELICAL LOCK WASHER
4	1	7/16-14	HEX NUT
5	2	M10 - 1.5 x 100 HEX	HEX BOLT
6	1	7_16-14 TAB NUT	HANDLE NUT

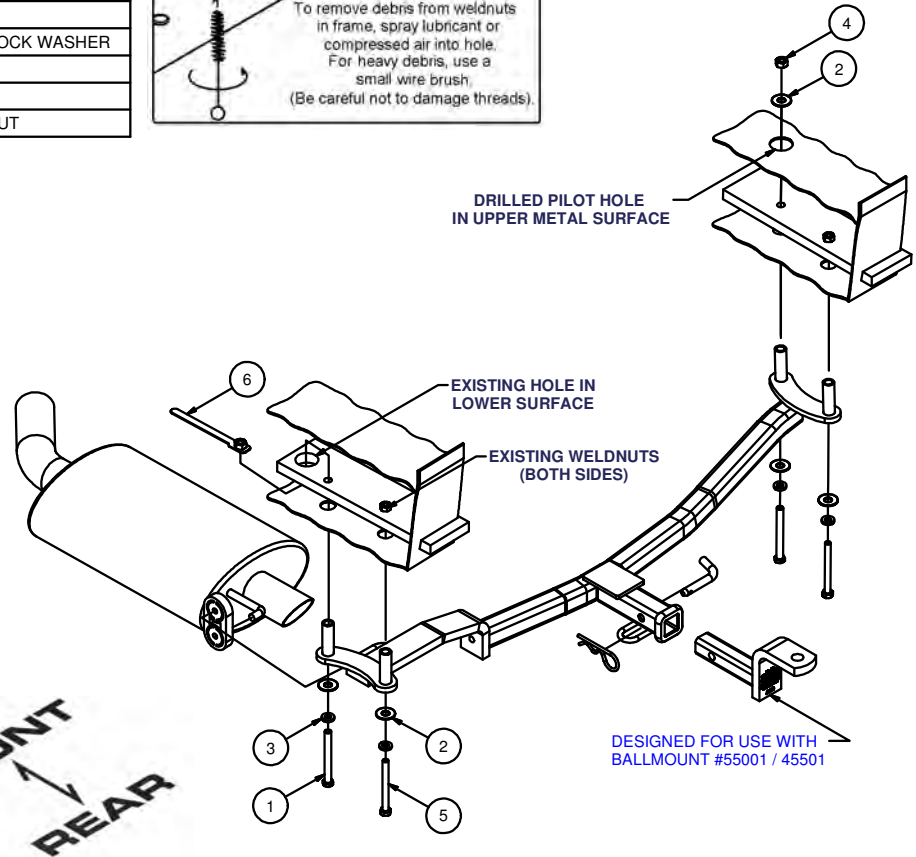
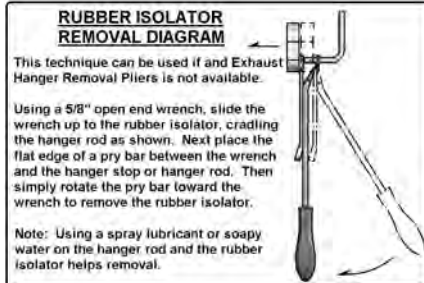
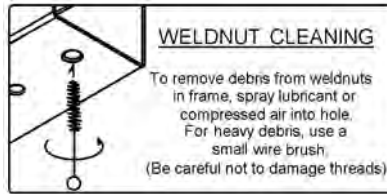

HITCH WEIGHT: 24 LBS.

INSTALL TIME

PROFESSIONAL: 30 MINUTES

NOVICE (DIY): 60 MINUTES

INSTALL NOTES:

- DRILLING REQUIRED
- REMOVE MUFFLER HANGER

INSTALLATION STEPS

1. Under the rear of the car on the left and right sides, locate one recessed 10mm bumper attachment screw on both sides. Remove both screws. Remove the muffler hanger at the rear of the muffler where it attaches to the chassis including the rubber isolator and metal bracket. Return the metal bracket to the car's owner for reinstallation should the hitch ever be removed.
2. PASSENGER SIDE ONLY: Clear inside the trunk area on the passenger side. Under the car, locate a round access hole in the lowest floor surface just forward of where the 10mm fasteners were removed. Note a 1/2 x 3/4" slot above the access hole. Drill one pilot hole centered on the slot up through the top metal surface into the trunk area. From inside the trunk, drill one 1 1/4 hole in the floor surface at the pilot hole to access the mounting washers, nut and wrench.
3. Position the hitch on the car with bridge passing over the exhaust. Use fasteners as shown to attach hitch where 10mm bolts were.
4. DRIVER'S SIDE ONLY: The bolt passes up from under the hitch as shown, and 7/16" handle but is placed through existing access hole under the car in lower surface just forward of the attaching point.
5. Remove the chassis metal bracket from the rubber exhaust hanger. The rubber hanger will now be supported by the metal loop on the hitch. Seal access hole made in step # 2 by placing permanent tape material over the hole.
6. Torque all 10mm fasteners to 45 lb-ft, and all 7/16" fastenes to 70 lb-ft.

PERIODICALLY CHECK THIS RECEIVER HITCH TO ENSURE THAT ALL FASTENERS ARE TIGHT AND THAT ALL STRUCTURAL COMPONENTS ARE SOUND.

Curt Manufacturing Inc., warrants this product to be free of defects in material and/or workmanship at the time of retail purchase by the original purchaser. If the product is found to be defective, Curt Manufacturing Inc., may repair or replace the product, at their option, when the product is returned, prepaid, with proof of purchase. Alteration to, misuse of, or improper installation of this product voids the warranty. Curt Manufacturing Inc.'s liability is limited to repair or replacement of products found to be defective, and specifically excludes liability for incidental or consequential loss or damage.