

11748

96-02 BMW Z3 CONVERTIBLE & COUPE (EXCEPT "M" VERSIONS)

11/30/2012

GROSS LOAD CAPACITY WHEN USED AS A WEIGHT CARRYING HITCH: 1,500 LBS. TRAILER WEIGHT & 150 LBS. TONGUE WEIGHT.

DO NOT EXCEED VEHICLE MANUFACTURER'S RECOMMENDED TOWING CAPACITY.

WARNING: ALL NON-TRAILER LOADS APPLIED TO THIS PRODUCT MUST BE SUPPORTED BY 18050 STABILIZING STRAPS.

** FAILURE TO PROPERLY SUPPORT NON-TRAILER LOADS WILL VOID PRODUCT WARRANTY**

HAVING INSTALLATION QUESTIONS? CALL TECHNICAL SUPPORT AT 1-800-798-0813

Parts List			
ITEM	QTY	PART NUMBER	DESCRIPTION
1	2	7/16-14 x 1 1/4	HEX BOLT
2	1	7/16-14 x 1.63 x 2.50 C-C	SQ. U-BOLT
3	2	3/8 - 16 x 3.531 x 1.875 C-C U-BOLT	U-BOLT
4	4	HFN3816	HEX FLANGE NUT
5	4	7/16-14	HEX FLANGE NUT

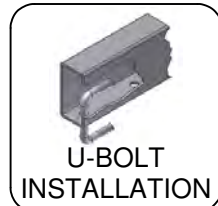
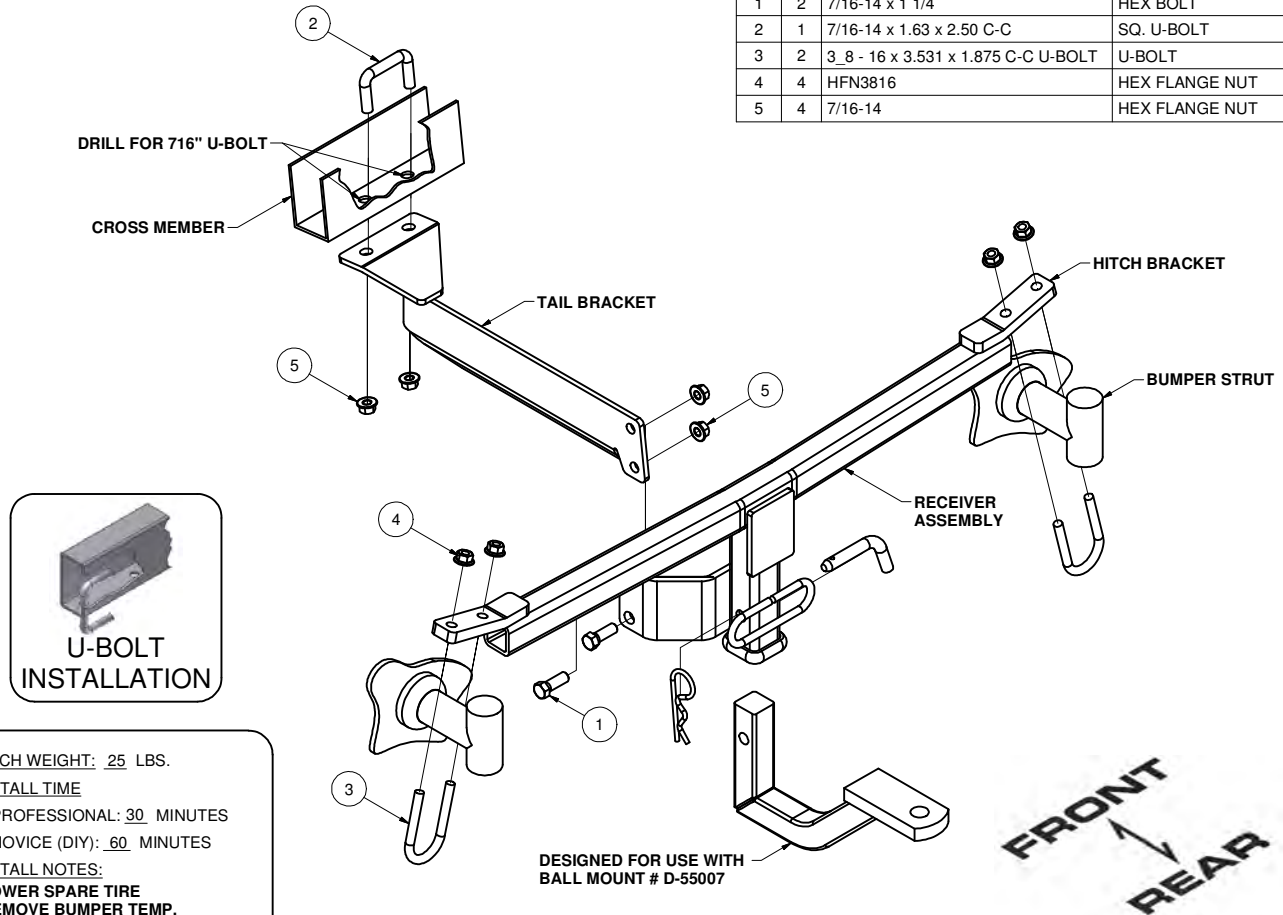

HITCH WEIGHT: .25 LBS.

INSTALL TIME

PROFESSIONAL: .30 MINUTES

NOVICE (DIY): .60 MINUTES

INSTALL NOTES:

- LOWER SPARE TIRE
- REMOVE BUMPER TEMP.
- UNFASTEN LICENSE PLATE LIGHTS
- DRILLING REQUIRED

DESIGNED FOR USE WITH
BALL MOUNT # D-55007

INSTALLATION STEPS

1. Lower spare tire and remove rear bumper by taking out large vertical bolt from each side which attaches the bumper to the bumper strut. Remove (4) fasteners attaching plastic fascia to the rear tire wells.
2. On each side, push the corners of the bumper in to release "T-slot" shaped fasteners, then pull down and rearward, being sure to clear plastic tire well. **Note:** License plate lights must be temporarily unfastened before bumper removal.
3. Position receiver assembly as shown in diagram, with hitch brackets on top of bumper struts and position as far forward as possible, install U-bolts and fasteners.
4. Position tail bracket assembly between exhaust heat shield and spare tire. Temporarily install fasteners. Mark crossmember for 1/2" holes to be drilled for rectangular U-bolt. Remove fasteners and tail bracket assembly and drill.
5. Install 7/16" U-bolt. Carefully place tail bracket assembly over u-bolt and install fasteners.
6. Torque 3/8" fasteners to 45 ft-lbs. Torque all 7/16" fasteners to 70 ft-lbs. **Note:** Do not use impact wrench on U-bolts.
7. Reinstall rear bumper using the large vertical bolts and (4) fascia fasteners that were removed in Step one. **Note:** Make sure to reinstall license plate lights.
8. Reinstall spare tire.

PERIODICALLY CHECK THIS RECEIVER HITCH TO ENSURE THAT ALL FASTENERS ARE TIGHT AND THAT ALL STRUCTURAL COMPONENTS ARE SOUND.

Curt Manufacturing Inc., warrants this product to be free of defects in material and/or workmanship at the time of retail purchase by the original purchaser. If the product is found to be defective, Curt Manufacturing Inc., may repair or replace the product, at their option, when the product is returned, prepaid, with proof of purchase. Alteration to, misuse of, or improper installation of this product voids the warranty. Curt Manufacturing Inc.'s liability is limited to repair or replacement of products found to be defective, and specifically excludes liability for incidental or consequential loss or damage.

247308