

11758**1975-1979 CHEVROLET CORVETTE**

12/7/2012

GROSS LOAD CAPACITY WHEN USED AS A WEIGHT CARRYING HITCH: 2,000 LBS. TRAILER WEIGHT & 200 LBS. TONGUE WEIGHT.

*****DO NOT EXCEED VEHICLE MANUFACTURER'S RECOMMENDED TOWING CAPACITY.*******WARNING: ALL NON-TRAILER LOADS APPLIED TO THIS PRODUCT MUST BE SUPPORTED BY AUXILIARY STABILIZING STRAPS.****** FAILURE TO PROPERLY SUPPORT NON-TRAILER LOADS WILL VOID PRODUCT WARRANTY****

HAVING INSTALLATION QUESTIONS? CALL TECHNICAL SUPPORT AT 1-800-798-0813

Parts List			
ITEM	QTY	PART NUMBER	DESCRIPTION
1	6	7/16 WASHER	WASHER
2	6	7/16 LOCK WASHER	HELICAL LOCK WASHER
3	2	CM-SP22	.250 x 1.50 x 1.50" ROUND HOLE SPACER
4	2	7_16 - 14 x 2 1_2 HEX	HEX BOLT
5	4	7/16-14	HEX NUT
6	2	7/16-14 x 1.63 x 2.50 C-C	SQ. U-BOLT

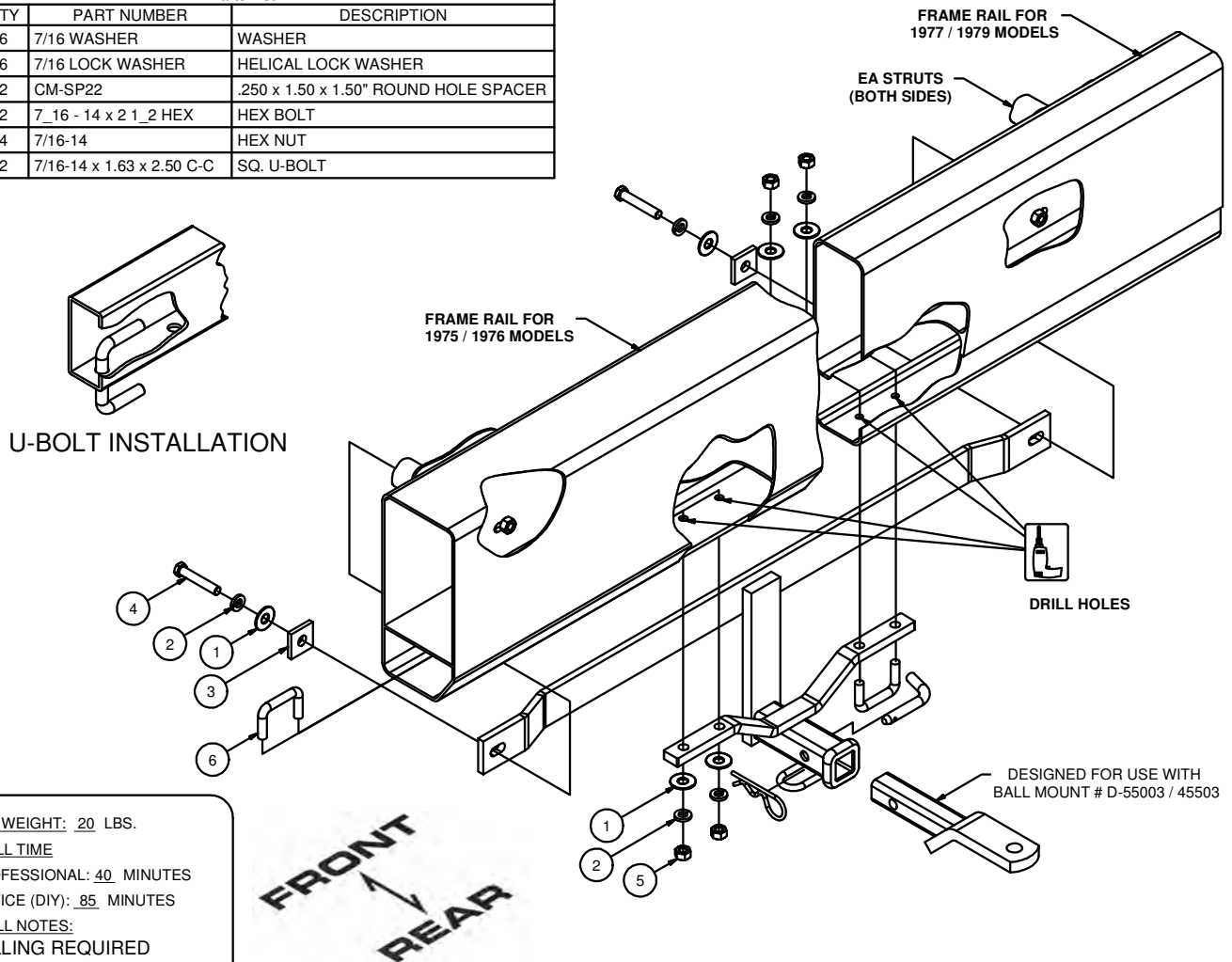

HITCH WEIGHT: 20 LBS.

INSTALL TIME

PROFESSIONAL: 40 MINUTES

NOVICE (DIY): 85 MINUTES

INSTALL NOTES:

-DRILLING REQUIRED

INSTALLATION STEPS

1. Remove the two lower, inside bolts fastening the bumper unit to the EA struts.
2. Install the hitch on the car by first mounting it at EA struts, using fasteners in two places as shown.

NOTE: 1977-79 models will require the spacers provided. Discard spacers for installation on earlier models.

3. The hitch will mount to the bumper member using two 7/16" rectangular U-bolts. Use the hitch as a template to drill four 1/2" diameter holes in the bumper for U-bolts.

NOTE: 1975-76 models will require blind installation of the U-bolts; see diagram. Later models will have direct access to place U-bolts. Four 7/16" fasteners can be substituted for U-bolts on later models if desired.

4. Torque all 7/16" fasteners to 70 lb-ft. DO NOT USE AN IMPACT WRENCH ON U-BOLTS.

NOTE: Some models may require relocation of convenience light at bumper.

PERIODICALLY CHECK THIS RECEIVER HITCH TO ENSURE THAT ALL FASTENERS ARE TIGHT AND THAT ALL STRUCTURAL COMPONENTS ARE SOUND.

Curt Manufacturing Inc., warrants this product to be free of defects in material and/or workmanship at the time of retail purchase by the original purchaser. If the product is found to be defective, Curt Manufacturing Inc., may repair or replace the product, at their option, when the product is returned, prepaid, with proof of purchase. Alteration to, misuse of, or improper installation of this product voids the warranty. Curt Manufacturing Inc.'s liability is limited to repair or replacement of products found to be defective, and specifically excludes liability for incidental or consequential loss or damage.