

11762**01-05 LEXUS IS300 SEDAN****5/3/2016****GROSS LOAD CAPACITY WHEN USED AS A WEIGHT CARRYING HITCH: 2,000 LBS. TRAILER WEIGHT & 200 LBS. TONGUE WEIGHT.**

DO NOT EXCEED VEHICLE MANUFACTURER'S RECOMMENDED TOWING CAPACITY.

WARNING: ALL NON-TRAILER LOADS APPLIED TO THIS PRODUCT MUST BE SUPPORTED BY 18050 STABILIZING STRAPS.

** FAILURE TO PROPERLY SUPPORT NON-TRAILER LOADS WILL VOID PRODUCT WARRANTY**

HAVING INSTALLATION QUESTIONS? CALL TECHNICAL SUPPORT AT 1-800-798-0813

Parts List			
ITEM	QTY	PART NUMBER	DESCRIPTION
1	1	CM-11762-SP	.188" SPACER
2	1	3/8 - 16 x 1	HEX BOLT
3	2	M12 - 1.25 x 40 HEX	HEX BOLT
4	2	7/16 WASHER	WASHER
5	2	1/2"	LOCK WASHER
6	4	3/8"	FENDER WASHER
7	4	3/8"	LOCK WASHER
8	4	3/8 - 16	HEX NUT
9	3	3/8 - 16 x 1 1/4	HEX BOLT

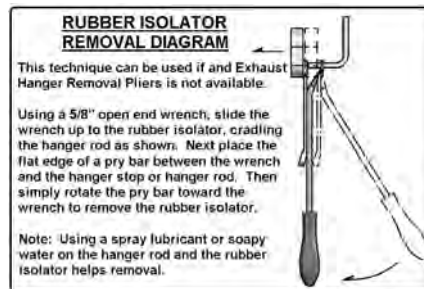
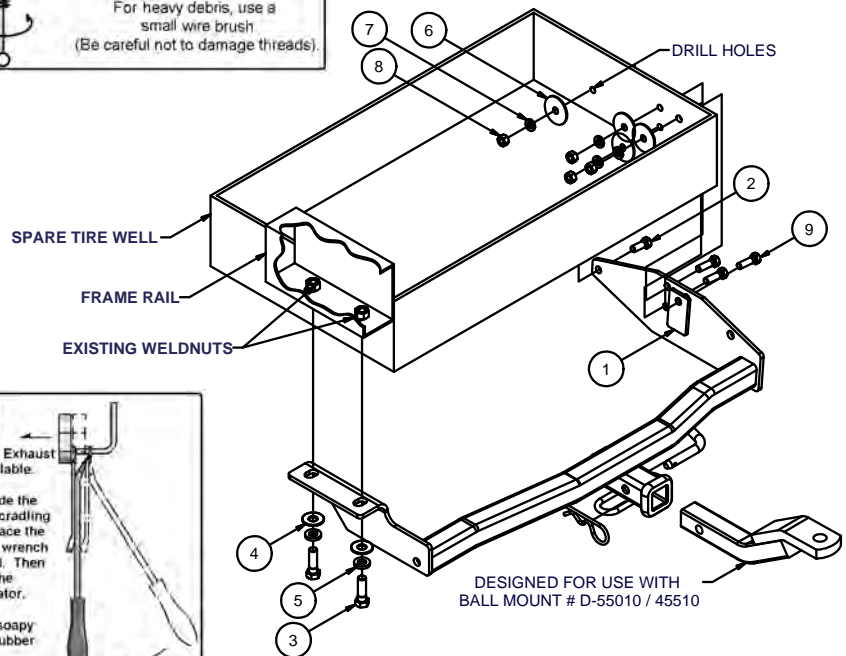
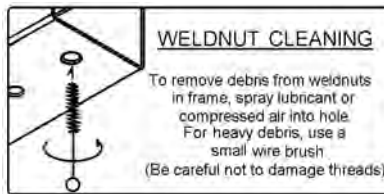

HITCH WEIGHT: .26 LBS.

INSTALL TIME

PROFESSIONAL: 30 MINUTES

NOVICE (DIY): 60 MINUTES

INSTALL NOTES:

- DRILLING REQUIRED
- REMOVE SPARE TIRE
- LOWER EXHAUST
- REMOVE HEAT SHIELD
- REMOVE PANEL
- REMOVE TIE DOWN BRACKET

INSTALLATION STEPS

1. Clear trunk and temporarily remove spare tire. Temporarily lower muffler by unfastening rearmost bracket. Temporarily remove heat shield and the plastic panel at bracket on driver's side. Remove the tie down bracket and disconnect (2) tabs at fascia bottom connecting fascia to body.
2. Position hitch up under fascia and body bringing (2) fascia tabs down under hitch to be reconnected. On driver's side, mount hitch at tie down weldnuts using M12 fasteners provided.
3. Position passenger side hitch bracket on spare tire well checking hitch to be level. Position bracket holes in best position on spare tire well ribs. Use hitch as a template and drill spare tire well (4) places for 3/8" diameter bolts. Access for drilling should be above muffler.
4. At front holes on passenger side, install fastener as shown placing bolt from OUTSIDE of the car. All washers and nuts are placed inside of the vehicle. At rear most hole on passenger side, (1) CM-11762-SP spacer is provided to fill tire well/bracket space. Spare tire may have to be shifted slightly in spare tire well for clearance when the tire is reinstalled.
5. Torque 3/8" fasteners to 45 ft-lb. and M12 fasteners to 86 ft-lb.
6. Use silicone sealant to seal hardware installed through spare tire well.
7. Reconnect fascia tabs. Reinstall heat shield and plastic panel. Raise exhaust back into position. Reinstall spare tire and other contents removed in Step 1.

PERIODICALLY CHECK THIS RECEIVER HITCH TO ENSURE THAT ALL FASTENERS ARE TIGHT AND THAT ALL STRUCTURAL COMPONENTS ARE SOUND.

Curt Manufacturing Inc., warrants this product to be free of defects in material and/or workmanship at the time of retail purchase by the original purchaser. If the product is found to be defective, Curt Manufacturing Inc., may repair or replace the product, at their option, when the product is returned, prepaid, with proof of purchase. Alteration to, misuse of, or improper installation of this product voids the warranty. Curt Manufacturing Inc.'s liability is limited to repair or replacement of products found to be defective, and specifically excludes liability for incidental or consequential loss or damage.