

11806**87-96 MERCEDES BENZ 300TE,TD & E320**

11/13/2017

GROSS LOAD CAPACITY WHEN USED AS A WEIGHT CARRYING HITCH: 2,000 LBS. TRAILER WEIGHT & 200 LBS. TONGUE WEIGHT.

DO NOT EXCEED VEHICLE MANUFACTURER'S RECOMMENDED TOWING CAPACITY.

WARNING: ALL NON-TRAILER LOADS APPLIED TO THIS PRODUCT MUST BE SUPPORTED BY AUXILIARY STABILIZING STRAPS.

** FAILURE TO PROPERLY SUPPORT NON-TRAILER LOADS WILL VOID PRODUCT WARRANTY**

HAVING INSTALLATION QUESTIONS? CALL TECHNICAL SUPPORT AT 1-800-798-0813

Parts List			
ITEM	QTY	PART NUMBER	DESCRIPTION
1	8	7/16-14 x 1 1/2	HEX BOLT
2	8	7/16 WASHER	WASHER
3	8	7/16-14	HEX FLANGE NUT
4	1	CM-11806-DSB	.188" DRIVER SIDE BRACKET
5	1	CM-11806-PSB	.188" PASSENGER SIDE BRACKET

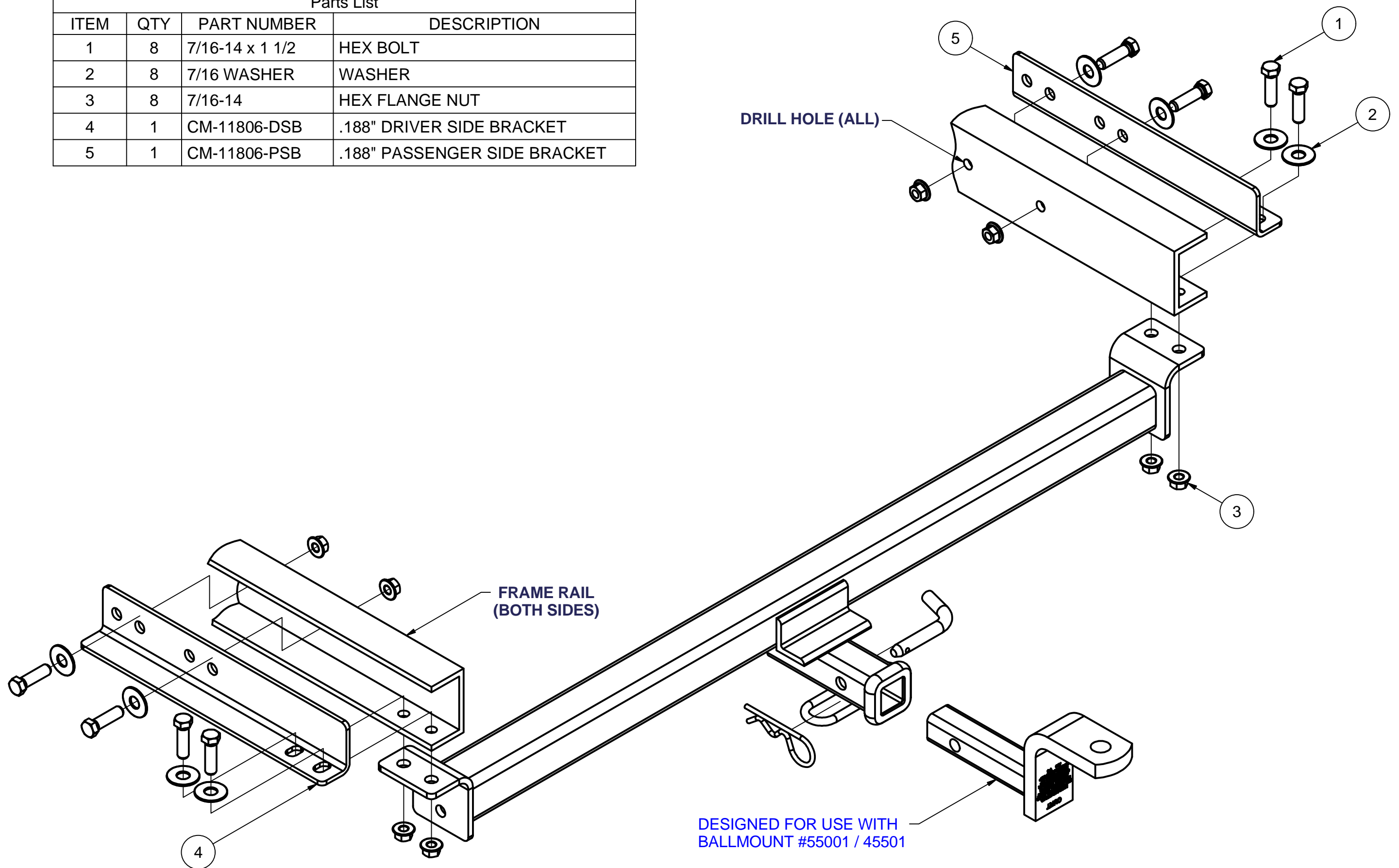

HITCH WEIGHT: 20 LBS.

INSTALL TIME

PROFESSIONAL: 20 MINUTES

NOVICE (DIY): 40 MINUTES

INSTALL NOTES:

- DRILLING REQUIRED
- REMOVE PANELS

INSTALLATION STEPS

1. Open rear door and remove the floor and wall panels for access to center compartment and side wells. Remove spare tire from left side well. Side wells are separated from center compartment by vertical metal panels, remove the two plugs in each panel. Left and right brackets provided with hitch must bolt at these panel holes inside each side well. Any body filler material blocking opening of side wells where bracket installs to must be cleaned away so channel rests flat on bodywork. Fasten channels to car as shown.
2. The hitch receiver assembly is placed up under car just forward of rear bumper and behind car's exhaust on flat area just large enough for receiver. Center hitch on car and drill mounting holes. Install fasteners as shown.
3. Torque all 7/16" hardware to 70 lb.-ft.
PERIODICALLY CHECK THIS RECEIVER HITCH TO ENSURE THAT ALL FASTENERS ARE TIGHT AND THAT ALL STRUCTURAL COMPONENTS ARE SOUND.

Curt Manufacturing Inc., warrants this product to be free of defects in material and/or workmanship at the time of retail purchase by the original purchaser. If the product is found to be defective, Curt Manufacturing Inc., may repair or replace the product, at their option, when the product is returned, prepaid, with proof of purchase. Alteration to, misuse of, or improper installation of this product voids the warranty. Curt Manufacturing Inc.'s liability is limited to repair or replacement of products found to be defective, and specifically excludes liability for incidental or consequential loss or damage.