

12037

1983-94 CHEVROLET S-BLAZER, 1983-94 GMC S-JIMMY
1991-94 OLDSMOBILE BRAVADA

11/30/2012

GROSS LOAD CAPACITY WHEN USED AS A WEIGHT CARRYING HITCH: 3500 LBS. TRAILER WEIGHT & 350 LBS. TONGUE WEIGHT.
*****DO NOT EXCEED VEHICLE MANUFACTURER'S RECOMMENDED TOWING CAPACITY.*****

Parts List			
ITEM	QTY	PART NUMBER	DESCRIPTION
1	4	HFN 1213	HEX FLANGE NUT
2	4	CM-SP1	.250 x 1.50 x 2.00" SQUARE HOLE SPACER
3	4	1/2-13 x 1 1/2	CARRIAGE BOLT

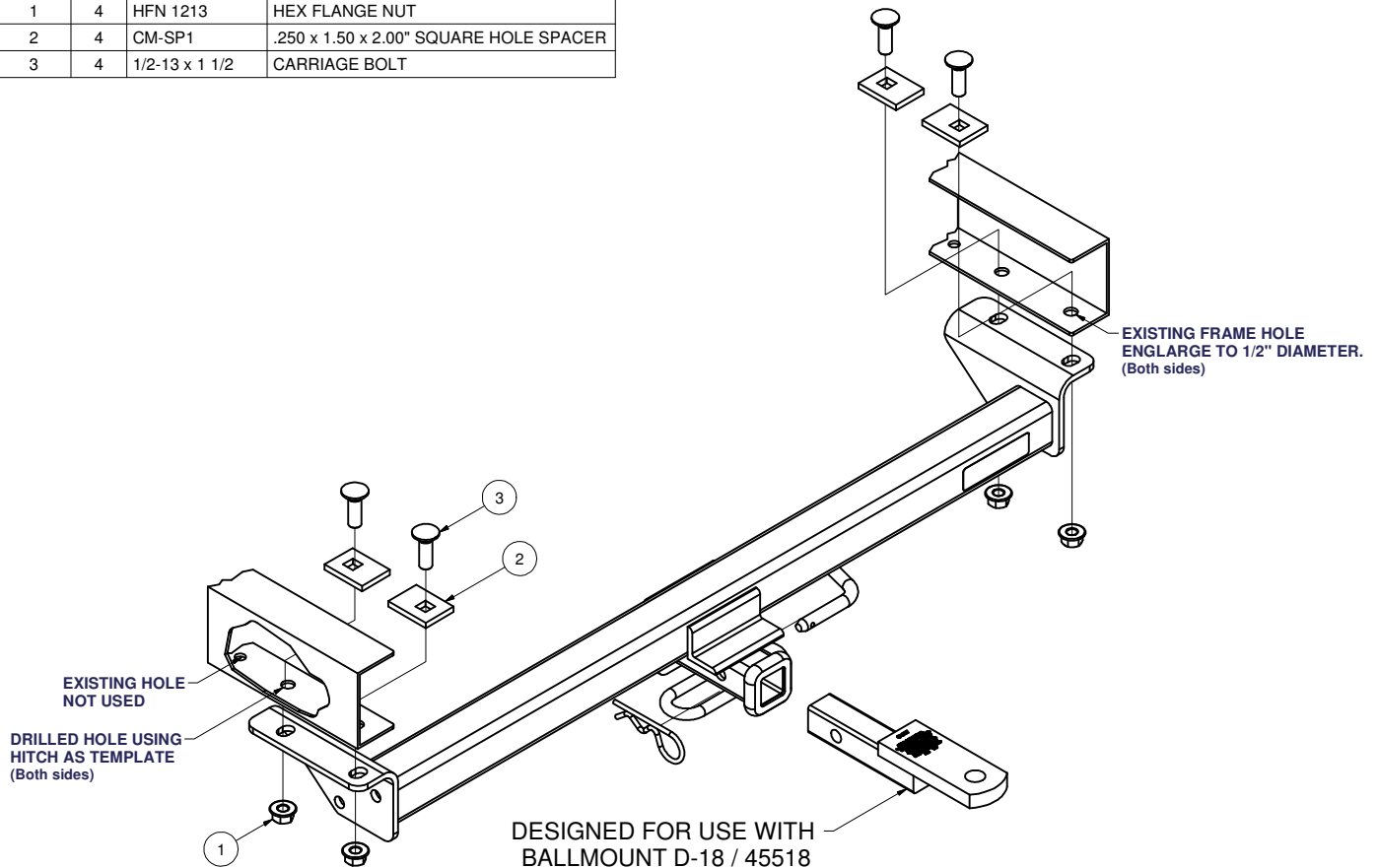

HITCH WEIGHT: 27 LBS.

INSTALL TIME: 20 MINUTES

INSTALL NOTES:

HOLE ENLARGEMENT REQUIRED

FRONT
↑
REAR

INSTALLATION STEPS

- 1) Remove any undercoating from the bottom of the vehicle frame at the hitch attachment points.
- 2) Using a 1/2" drill bit enlarge the existing frame hole nearest the bumper.(Both sides)
- 3) Raise the hitch into position and attach it to the frame using the previously enlarged frame hole near the bumper. Fasten the hitch using the 1/2-13 hardware and block spacers provided.
- 4) Use the hitch as a template to drill a 1/2" diameter hole at the forwardmost mounting locations.
- 5) Install remaining fasteners and torque all components to 110lb./ft.

PERIODICALLY CHECK THIS RECEIVER HITCH TO ENSURE THAT ALL FASTENERS ARE TIGHT AND THAT ALL STRUCTURAL COMPONENTS ARE SOUND.

Curt Manufacturing Inc., warrants this product to be free of defects in material and/or workmanship at the time of retail purchase by the original purchaser. If the product is found to be defective, Curt Manufacturing Inc., may repair or replace the product, at their option, when the product is returned, prepaid, with proof of purchase. Alteration to, misuse of, or improper installation of this product voids the warranty. Curt Manufacturing Inc.'s liability is limited to repair or replacement of products found to be defective, and specifically excludes liability for incidental or consequential loss or damage.