

12070

CADILLAC SRX

10/19/2012

GROSS LOAD CAPACITY WHEN USED AS A WEIGHT CARRYING HITCH: 3,500 LBS. TRAILER WEIGHT & 350 LBS. TONGUE WEIGHT.

*****DO NOT EXCEED VEHICLE MANUFACTURER'S RECOMMENDED TOWING CAPACITY.*****

WARNING: ALL NON-TRAILER LOADS APPLIED TO THIS PRODUCT MUST BE SUPPORTED BY AUXILIARY STABILIZING STRAPS.

**** FAILURE TO PROPERLY SUPPORT NON-TRAILER LOADS WILL VOID PRODUCT WARRANTY****

HAVING INSTALLATION QUESTIONS? CALL TECHNICAL SUPPORT AT 1-800-798-0813

Parts List			
ITEM	QTY	PART NUMBER	DESCRIPTION
1	6	M12-1.75 x 30mm	HEX BOLT
2	6	1/2"	CONICAL TOOTHED WASHER

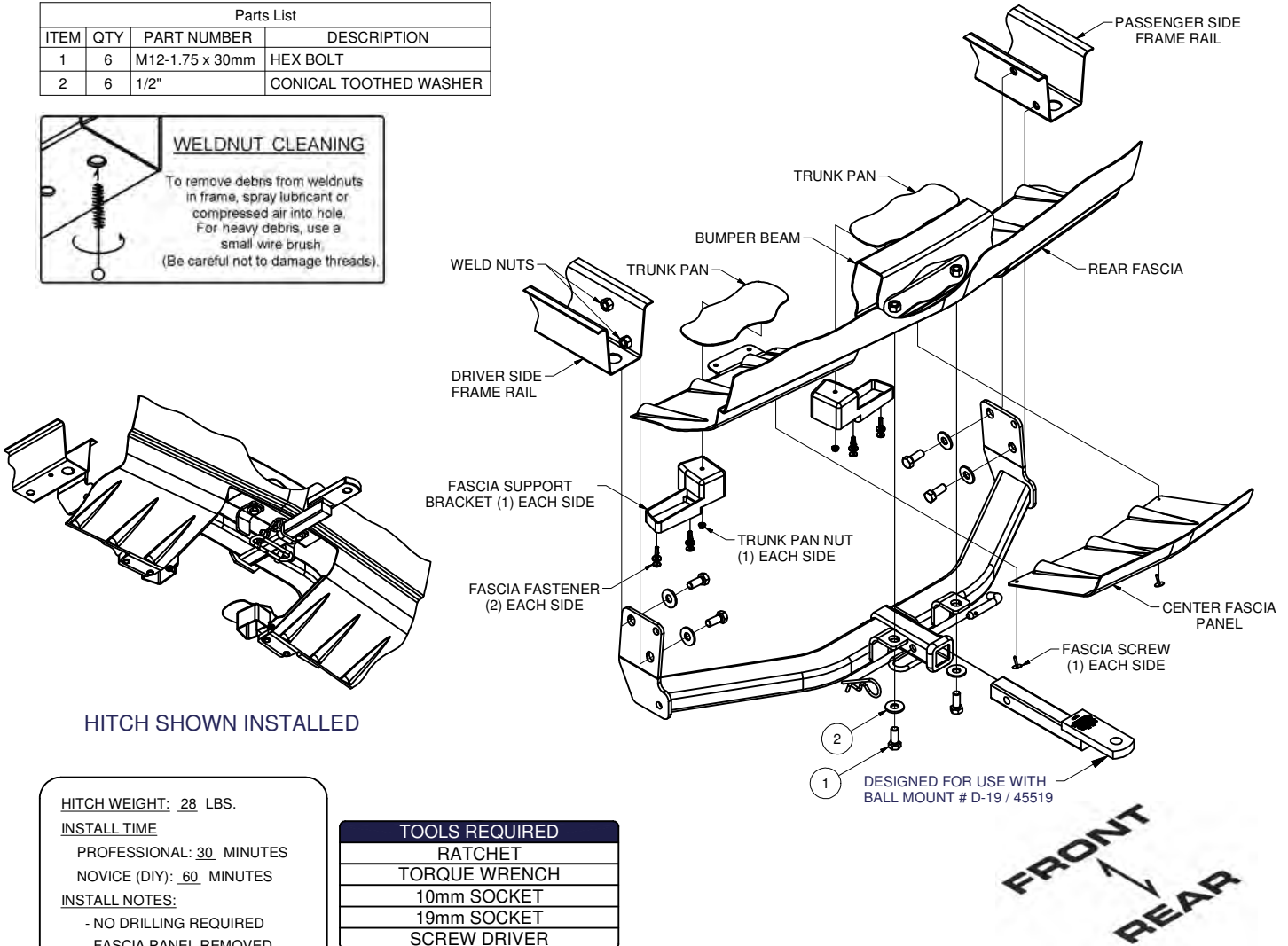
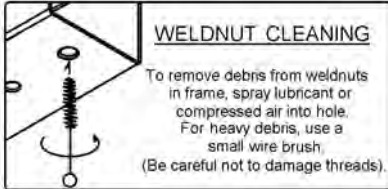

HITCH SHOWN INSTALLED

HITCH WEIGHT: 28 LBS.

INSTALL TIME

PROFESSIONAL: 30 MINUTES

NOVICE (DIY): 60 MINUTES

INSTALL NOTES:

- NO DRILLING REQUIRED
- FASCIA PANEL REMOVED

TOOLS REQUIRED
RATCHET
TORQUE WRENCH
10mm SOCKET
19mm SOCKET
SCREW DRIVER

INSTALLATION STEPS

1. Remove (2) screws securing the center fascia panel. Release center fascia panel tabs and remove panel.
2. Remove (4) plastic push fasteners securing the rear fascia to the fascia support brackets. Remove the (2) nuts securing the fascia support brackets to the trunk pan. Retain brackets and fasteners, they will be reinstalled later.
3. Raise hitch into position and secure using M12-1.75 x 30mm bolts and 1/2" conical toothed washers. **Note:** Slide the driver side plate between the wiring harness and the driver side frame rail. You may need to pull down on rear fascia to slide hitch between the trunk pan and fascia
4. Reinstall fascia support brackets and fasteners.
5. Torque all M12 fasteners to 79 ft-lbs.
6. Return center fascia panel and fasteners to owner.

PERIODICALLY CHECK THIS RECEIVER HITCH TO ENSURE THAT ALL FASTENERS ARE TIGHT AND THAT ALL STRUCTURAL COMPONENTS ARE SOUND.

Curt Manufacturing Inc., warrants this product to be free of defects in material and/or workmanship at the time of retail purchase by the original purchaser. If the product is found to be defective, Curt Manufacturing Inc., may repair or replace the product, at their option, when the product is returned, prepaid, with proof of purchase. Alteration to, misuse of, or improper installation of this product voids the warranty. Curt Manufacturing Inc.'s liability is limited to repair or replacement of products found to be defective, and specifically excludes liability for incidental or consequential loss or damage.



12070 INSTALLATION INSTRUCTIONS



Safety glasses should be worn at all times while installing this product.

YEARS: 2010-PRESENT

MAKE: CADILLAC

MODEL: SRX

STYLE: CROSSOVER

WARNING: NEVER EXCEED YOUR VEHICLE MANUFACTURER'S RECOMMENDED TOWING CAPACITY

WEIGHT CARRYING:
TRAILER WEIGHT: 3,500 LBS.
TONGUE WEIGHT: 350 LBS.

WARNING:
WE STRONGLY RECOMMEND THE USE OF AUXILIARY STABILIZING STRAPS FOR ALL NON-TRAILER (WHEEL-LESS) LOADS. PLEASE SEE THE CURT CATALOG OR VISIT US ONLINE AT WWW.CURTMFG.COM FOR FURTHER INFORMATION.

INSTALLATION TIME: 30 MIN.

THE INSTALL TIME LISTED IS FOR PROFESSIONAL INSTALLERS. IF YOU ARE HESITANT TO UNDERTAKE THIS TASK ON YOUR OWN, CONTACT AN AUTHORIZED CURT INSTALLER FOR ADDITIONAL ASSISTANCE.

INSTALLATION REQUIRES:

 TORQUE WRENCH	 RATCHET	 10mm 19mm SOCKET
 SCREW DRIVER	 WIRE PIPE BRUSH	 MASKING TAPE

INSTALLATION TIPS:

- BEFORE YOU BEGIN INSTALLATION, READ ALL INSTRUCTIONS THOROUGHLY.
- TO EASE INSTALLATION, 2 PEOPLE MAY BE REQUIRED.
- USING PROPER TOOLS WILL GREATLY IMPROVE THE QUALITY OF THE INSTALL AND REDUCE THE TIME REQUIRED.
- NEED HELP OR HAVE SOME QUESTIONS? CALL TECHNICAL SUPPORT AT 800.798.0813

LEVEL OF DIFFICULTY: MODERATE

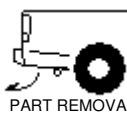
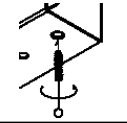
EASY	MODERATE	HARD
	NO DRILLING REQUIRED	
	REMOVE CENTER FASCIA PANEL AND RETURN TO OWNER	
	MAY REQUIRE WELDNUT CLEANING	

VEHICLE PHOTO:



REPRESENTATIVE PHOTO

HITCH ILLUSTRATION:

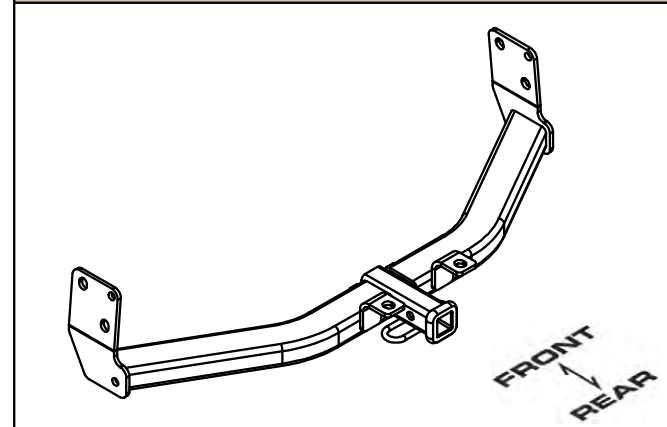

MAKE SURE YOUR HITCH MATCHES

PERIODICALLY CHECK THIS RECEIVER HITCH TO ENSURE ALL FASTENERS ARE TIGHT AND ALL STRUCTURAL COMPONENTS ARE SOUND

CURT Manufacturing Inc. warrants this product to be free of defects in material and/or workmanship at the time of retail purchase by the original purchaser. If the product is found to be defective, Curt Manufacturing Inc. may repair or replace the product at their option, when the product is returned, prepaid, with proof of purchase. Alteration to, misuse of, or improper installation of this product voids the warranty. Curt Manufacturing Inc.'s liability is limited to repair or replacement of products found to be defective, and specifically excludes liability for incidental or consequential loss or damage.

For more information log onto www.curtmfg.com, & for helpful towing tips log onto www.hitchinfo.com

10/19/2012

INSTALLATION WALKTHROUGH:

Parts List			
ITEM	QTY	PART NUMBER	DESCRIPTION
1	6	M12-1.75 x 30mm	HEX BOLT
2	6	1/2"	CONICAL TOOTHED WASHER

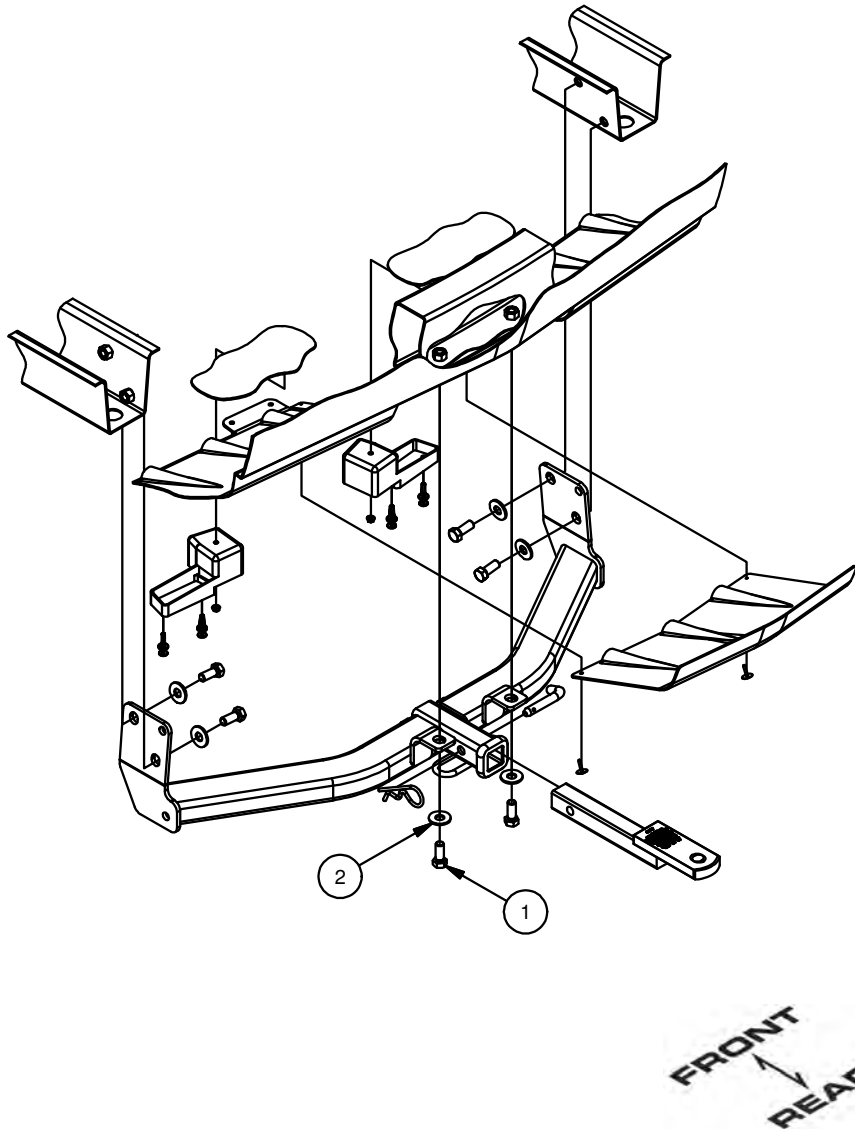

1. Using a phillips screw driver remove (2) screws securing the center fascia panel. Release center fascia panel tabs and remove panel.



- ↓
2. If you are going to install a trailer wiring harness do this prior to installing hitch.



INSTALLATION WALKTHROUGH:

3. Using flat blade screw driver remove (4) plastic push fasteners securing the rear fascia to the fascia support brackets. Using a 10mm socket remove the (2) nuts securing the fascia support brackets to the trunk pan.



4. Pull down on rear fascia and remove fascia support brackets. The second photo shows the hardware removed. **Note:** Use masking tape to protect vehicle finish. Brackets will be reinstated in Step 6.



5. Raise hitch into position and secure using M12-1.75 x 30mm bolts and 1/2" conical toothed washers. **Note:** Slide the driver side plate between the wiring harness and the driver side frame rail. You may need to pull down on rear fascia to slide hitch between the trunk pan and fascia.

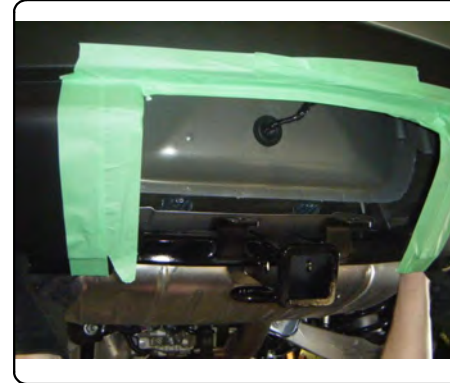

6. Reinstall fascia support brackets and fasteners. Torque all M12 fasteners to 79 ft-lbs.



INSTALLATION WALKTHROUGH:

7. Hitch shown installed properly. Return center fascia panel and fasteners to owner.



INSTALLATION IS NOW COMPLETE