



Safety glasses should be worn at all times while installing this product.

YEARS: 2013-2014

MAKE: FORD/LINCOLN

MODEL: ESCAPE/MKC

STYLE: SUV

WARNING: NEVER EXCEED YOUR VEHICLE MANUFACTURER'S RECOMMENDED TOWING CAPACITY

WEIGHT CARRYING:
 TRAILER WEIGHT: 3,500 LBS.
 TONGUE WEIGHT: 350 LBS.

WARNING:
 WE RECOMMEND THE USE OF 18050 STABILIZING STRAPS FOR ALL NON-TRAILER (WHEEL-LESS) LOADS. PLEASE SEE THE CURT CATALOG OR VISIT US ONLINE AT WWW.CURTMFG.COM FOR FURTHER INFORMATION.

INSTALLATION TIME: 45 MIN.

THE INSTALL TIME LISTED IS FOR PROFESSIONAL INSTALLERS. IF YOU ARE HESITANT TO UNDERTAKE THIS TASK ON YOUR OWN, CONTACT AN AUTHORIZED CURT INSTALLER FOR ADDITIONAL ASSISTANCE.

INSTALLATION REQUIRES:

		10 mm 13 mm 11/16"
SAFETY GLASSES	RATCHET	SOCKET
6"		
SOCKET EXTENSION	DIE GRINDER	AVIATION SHEARS
13 mm		
BOXED END WRENCH 13 mm	TORQUE WRENCH	

INSTALLATION TIPS:

- BEFORE YOU BEGIN INSTALLATION, READ ALL INSTRUCTIONS THOROUGHLY.
- TO EASE INSTALLATION, 2 PEOPLE MAY BE REQUIRED.
- USING PROPER TOOLS WILL GREATLY IMPROVE THE QUALITY OF THE INSTALL AND REDUCE THE TIME REQUIRED.
- NEED HELP OR HAVE SOME QUESTIONS? CALL TECHNICAL SUPPORT AT 800.798.0813

LEVEL OF DIFFICULTY: MODERATE

EASY	MODERATE	CHALLENGING
	LOWER EXHAUST TO EASE INSTALLATION	
	HOLE ENLARGEMENT REQUIRED	
	FISHWIRING REQUIRED	
	HEATSHEILD TRIMMING	

VEHICLE PHOTO:



REPRESENTATIVE PHOTO

HITCH ILLUSTRATION:

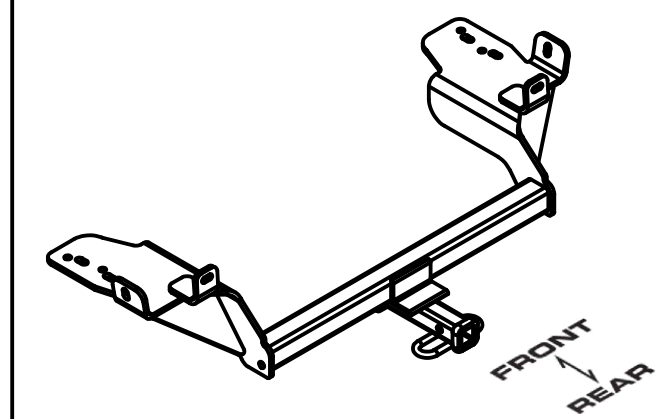

MAKE SURE YOUR HITCH MATCHES

PERIODICALLY CHECK THIS RECEIVER HITCH TO ENSURE ALL FASTENERS ARE TIGHT AND ALL STRUCTURAL COMPONENTS ARE SOUND

CURT Manufacturing LLC. warrants this product to be free of defects in material and/or workmanship at the time of retail purchase by the original purchaser. If the product is found to be defective, Curt Manufacturing LLC. may repair or replace the product at their option, when the product is returned, prepaid, with proof of purchase. Alteration to, misuse of, or improper installation of this product voids the warranty. Curt Manufacturing LLC.'s liability is limited to repair or replacement of products found to be defective, and specifically excludes liability for incidental or consequential loss or damage.

For more information log onto www.curtmfg.com, & for helpful towing tips log onto www.hitchinfo.com

INSTALLATION WALKTHROUGH:

Parts List			
ITEM	QTY	PART NUMBER	DESCRIPTION
1	6	7_16 FISHWIRE	7/16" FISHWIRE
2	6	CM-SP11	.250 x 1.00 x 2.50" SPACER
3	6	7/16-14 x 1 1/2	CARRIAGE BOLT
4	6	7/16-14	HEX FLANGE NUT
5	6	M8 - 1.25 x 30 HEX BOLT	HEX HEAD BOLT
6	12	5/16"	WASHER
7	2	M8 - 1.25 HEX FLANGE NUT	HEX FLANGE NUT

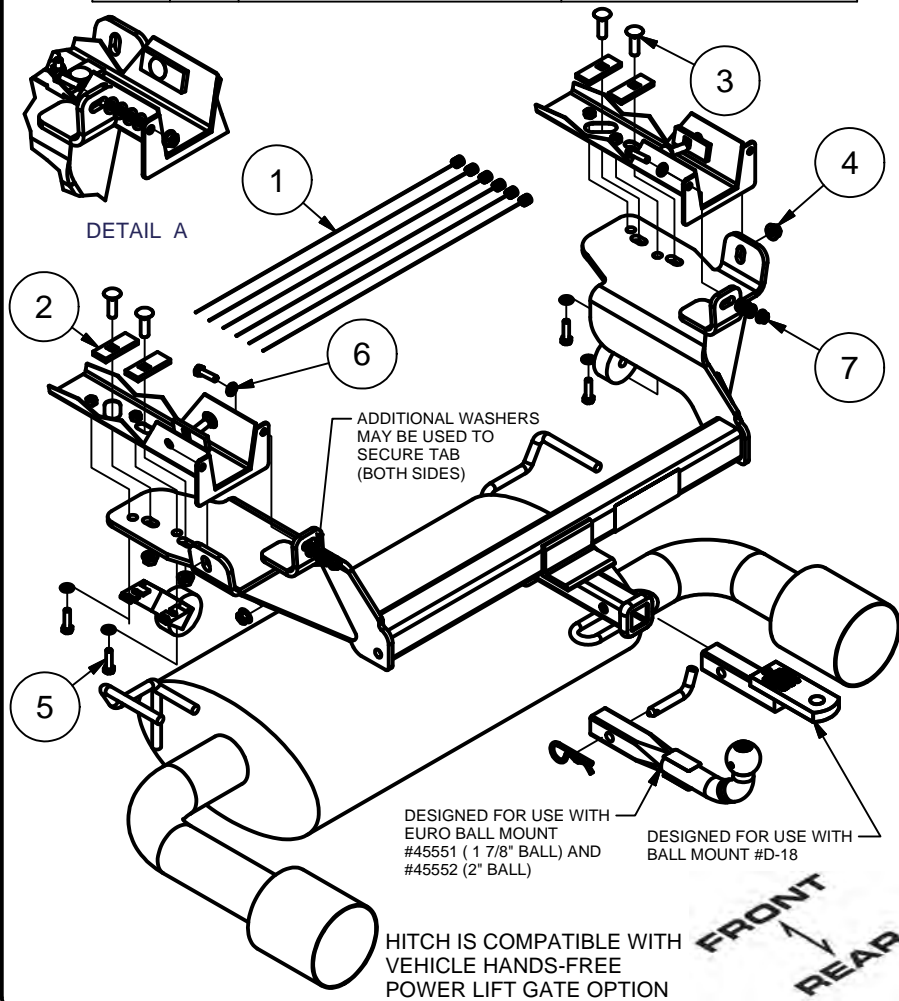

1. Lower exhaust by removing isolator bracket bolts with a 13 mm socket on each side of vehicle. Exhaust hanger on forward driver side of vehicle will also need to be disconnected for ease of installation.

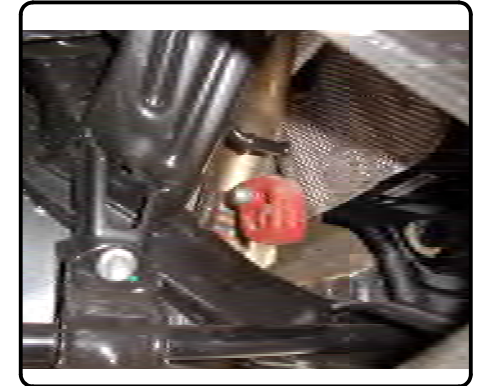

2. The exhaust heat shield will need to be removed to mount the hitch side brackets. Remove the bolt from the driver side with a 10 mm socket and either bend the heat shield away, or trim as shown and reattach to the existing mounting point.



INSTALLATION WALKTHROUGH:

3. Enlarge access holes for square hole spacers with a die grinder. Fishwire 7/16" bolts and spacers into vehicle frame for the (3) side bracket mounting points on each side of the vehicle.



4. Slide hitch in from rear passenger side of vehicle for ease of installation and mount up to frame and secure to fishwired hardware. Secure rear mounting hardware to rear mounting surface once hitch is in place.



5. Reattach muffler isolator brackets to original mounting locations, at bottom surface of hitch side brackets. Torque all 7/16" fasteners to 70 ft-lbs. Torque all M8 fasteners to 23 ft-lbs.



6. Installation is complete.



12084**FORD ESCAPE & LINCOLN MKC****7/22/2014****GROSS LOAD CAPACITY WHEN USED AS A WEIGHT CARRYING HITCH: 3,500 LBS. TRAILER WEIGHT & 350 LBS. TONGUE WEIGHT.**

DO NOT EXCEED VEHICLE MANUFACTURER'S RECOMMENDED TOWING CAPACITY.

WARNING: ALL NON-TRAILER LOADS APPLIED TO THIS PRODUCT MUST BE SUPPORTED BY 18050 STABILIZING STRAPS.

** FAILURE TO PROPERLY SUPPORT NON-TRAILER LOADS WILL VOID PRODUCT WARRANTY**

HAVING INSTALLATION QUESTIONS? CALL TECHNICAL SUPPORT AT 1-800-798-0813

Parts List			
ITEM	QTY	PART NUMBER	DESCRIPTION
1	12	5/16"	WASHER
2	6	7_16 FISHWIRE	7/16" FISHWIRE
3	6	M8 - 1.25 x 30 HEX BOLT	HEX HEAD BOLT
4	6	7/16-14 x 1 1/2	CARRIAGE BOLT
5	6	CM-SP11	.250 x 1.00 x 2.50" SQUARE HOLE SPACER
6	2	M8 - 1.25 HEX FLANGE NUT	HEX FLANGE NUT
7	6	7/16-14	HEX FLANGE NUT

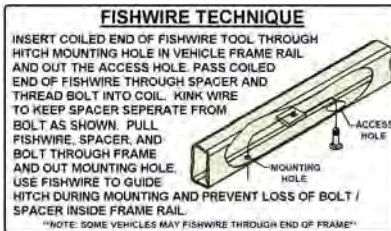

TOOLS REQUIRED

RATCHET
SOCKET SET
6" SOCKET EXTENSION
DIE GRINDER
SHEARS
BOXED END WRENCH
TORWUE WRENCH

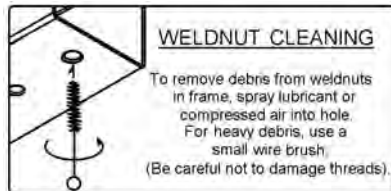

HITCH WEIGHT: 37 LBS.

INSTALL TIME

PROFESSIONAL: 45 MINUTES

NOVICE (DIY): 90 MINUTES

INSTALL NOTES:

- HOLE ENLARGEMENT
- FISHWIRING REQUIRED
- TRIMMING RECOMMENDED

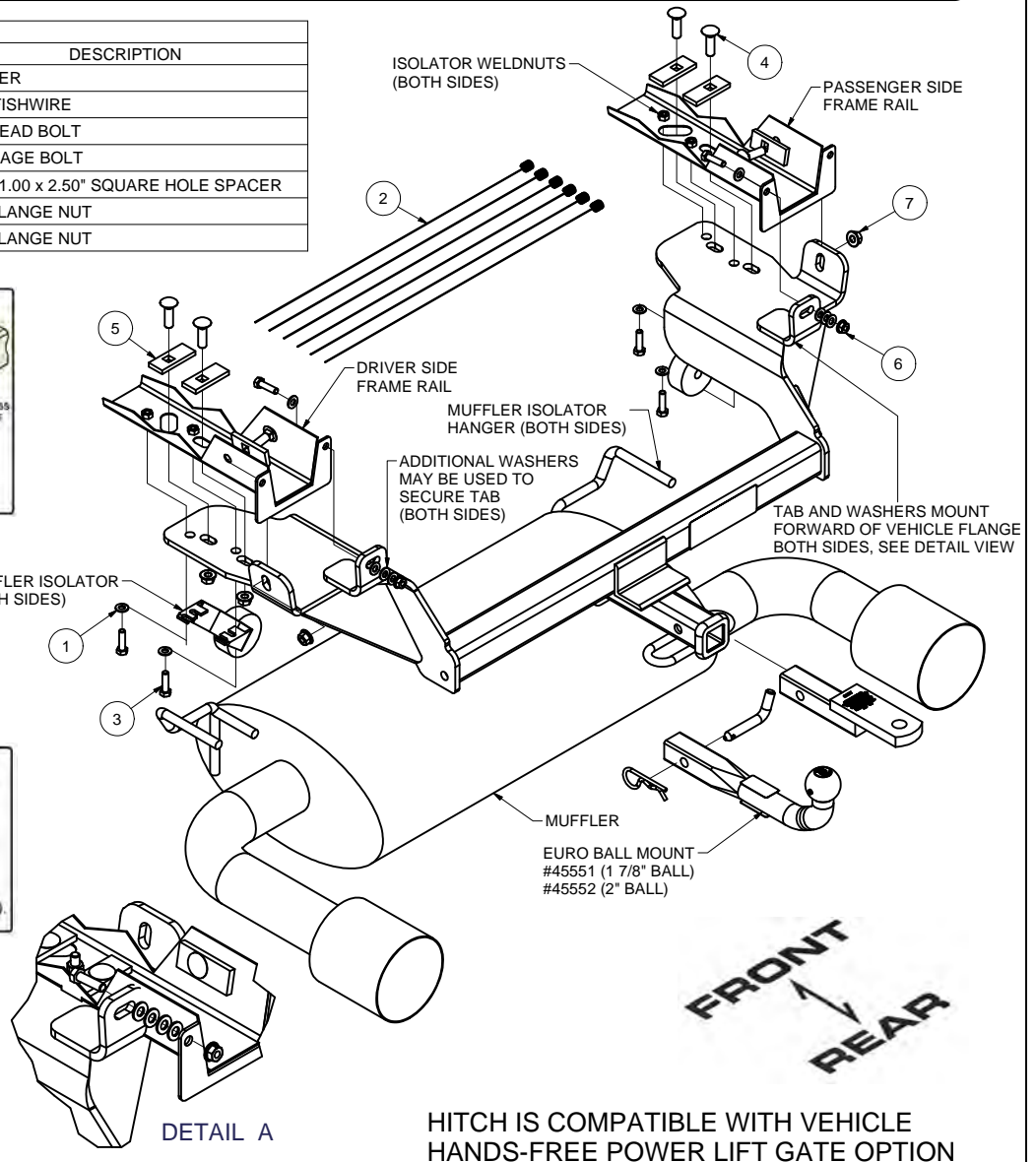
**HITCH IS COMPATIBLE WITH VEHICLE HANDS-FREE POWER LIFT GATE OPTION****INSTALLATION STEPS**

1. Lower exhaust by removing isolator bracket bolts with a 13 mm socket on each side of vehicle. Exhaust hanger on forward driver side of vehicle will also need to be disconnected for ease of installation.
2. The exhaust heat shield will need to be removed to mount the hitch side brackets. Remove the bolt from the driver side with a 10 mm socket and either bend the heat shield away, or trim and reattach to the existing mounting point.
3. Enlarge access holes for square hole spacers with a die grinder. Fishwire 7/16" bolts and spacers into vehicle frame for the (3) side bracket mounting points on each side of the vehicle.
4. Slide hitch in from rear passenger side of vehicle for ease of installation and mount up to frame and secure to fishwired hardware. Secure rear mounting hardware to rear mounting surface once hitch is in place.
5. Reattach muffer isolator brackets to original mounting locations, at bottom surface of hitch side brackets. Torque all 7/16" fasteners to 70 ft-lbs. Torque all M8 fasteners to 23 ft-lbs.
6. Installation is complete.

PERIODICALLY CHECK THIS RECEIVER HITCH TO ENSURE THAT ALL FASTENERS ARE TIGHT AND THAT ALL STRUCTURAL COMPONENTS ARE SOUND.

Curt Manufacturing LLC., warrants this product to be free of defects in material and/or workmanship at the time of retail purchase by the original purchaser. If the product is found to be defective, Curt Manufacturing LLC., may repair or replace the product, at their option, when the product is returned, prepaid, with proof of purchase. Alteration to, misuse of, or improper installation of this product voids the warranty. Curt Manufacturing LLC.'s liability is limited to repair or replacement of products found to be defective, and specifically excludes liability for incidental or consequential loss or damage.