



Safety glasses should be worn at all times while installing this product.

YEARS: 2016-PRESENT

MAKE: CHEVROLET

MODEL: MALIBU

STYLE: SEDAN

WARNING: NEVER EXCEED YOUR VEHICLE MANUFACTURER'S RECOMMENDED TOWING CAPACITY
 For more information log onto www.curtmfg.com & for helpful towing tips log onto www.hitchinfo.com

WEIGHT CARRYING:
 TRAILER WEIGHT: 3,500 LBS.
 TONGUE WEIGHT: 350 LBS.

WARNING:
 WE RECOMMEND THE USE OF 18050 STABILIZING STRAPS FOR ALL NON-TRAILER (WHEEL-LESS) LOADS. PLEASE SEE THE CURT CATALOG OR VISIT US ONLINE AT WWW.CURTMFG.COM FOR FURTHER INFORMATION.

PRO INSTALL TIME: 30 MIN.
NOVICE INSTALL TIME: 60 MIN.

IF YOU ARE HESITANT TO UNDERTAKE THIS TASK ON YOUR OWN, CONTACT AN AUTHORIZED CURT INSTALLER FOR ADDITIONAL ASSISTANCE.

INSTALLATION REQUIRES:

		8"
SAFETY GLASSES	TORQUE WRENCH	SOCKET EXTENSION
	13mm 15mm 1 1/16"	
RATCHET	SOCKET	MASKING TAPE
AVIATION SHEARS		

INSTALLATION TIPS:

- BEFORE YOU BEGIN INSTALLATION, READ ALL INSTRUCTIONS THOROUGHLY.
- TO EASE INSTALLATION, 2 PEOPLE MAY BE REQUIRED.
- USING PROPER TOOLS WILL GREATLY IMPROVE THE QUALITY OF THE INSTALL AND REDUCE THE TIME REQUIRED.
- NEED HELP OR HAVE SOME QUESTIONS? CALL TECHNICAL SUPPORT AT 800.798.0813

LEVEL OF DIFFICULTY: MODERATE

EASY	MODERATE	CHALLENGING
	NO DRILLING REQUIRED	
	TEMPORARILY REMOVE EXHAUST	
	TRIM HEAT SHIELD	

VEHICLE PHOTO:



REPRESENTATIVE PHOTO

HITCH ILLUSTRATION:

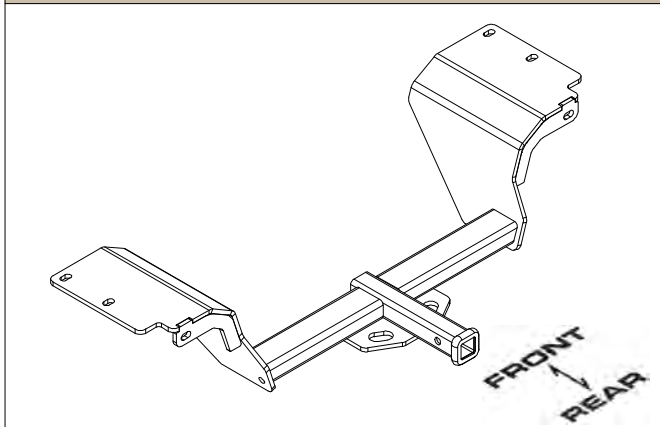

MAKE SURE YOUR HITCH MATCHES



SCAN FOR MORE INFO

PERIODICALLY CHECK THIS RECEIVER HITCH TO ENSURE ALL FASTENERS ARE TIGHT AND ALL STRUCTURAL COMPONENTS ARE SOUND
 CURT Manufacturing LLC. warrants this product to be free of defects in material and/or workmanship at the time of retail purchase by the original purchaser. If the product is found to be defective, CURT Manufacturing LLC. may repair or replace the product at their option, when the product is returned, prepaid, with proof of purchase. Alteration to, misuse of, or improper installation of this product voids the warranty. CURT Manufacturing LLC.'s liability is limited to repair or replacement of products found to be defective, and specifically excludes liability for incidental or consequential loss or damage.
For more information log onto www.curtmfg.com , & for helpful towing tips log onto www.hitchinfo.com
 This product complies with safety specifications and requirements for connecting devices and towing systems of the state of New York, V.E.S.C.Regulation V-5 and SAE J684.

INSTALLATION WALKTHROUGH:

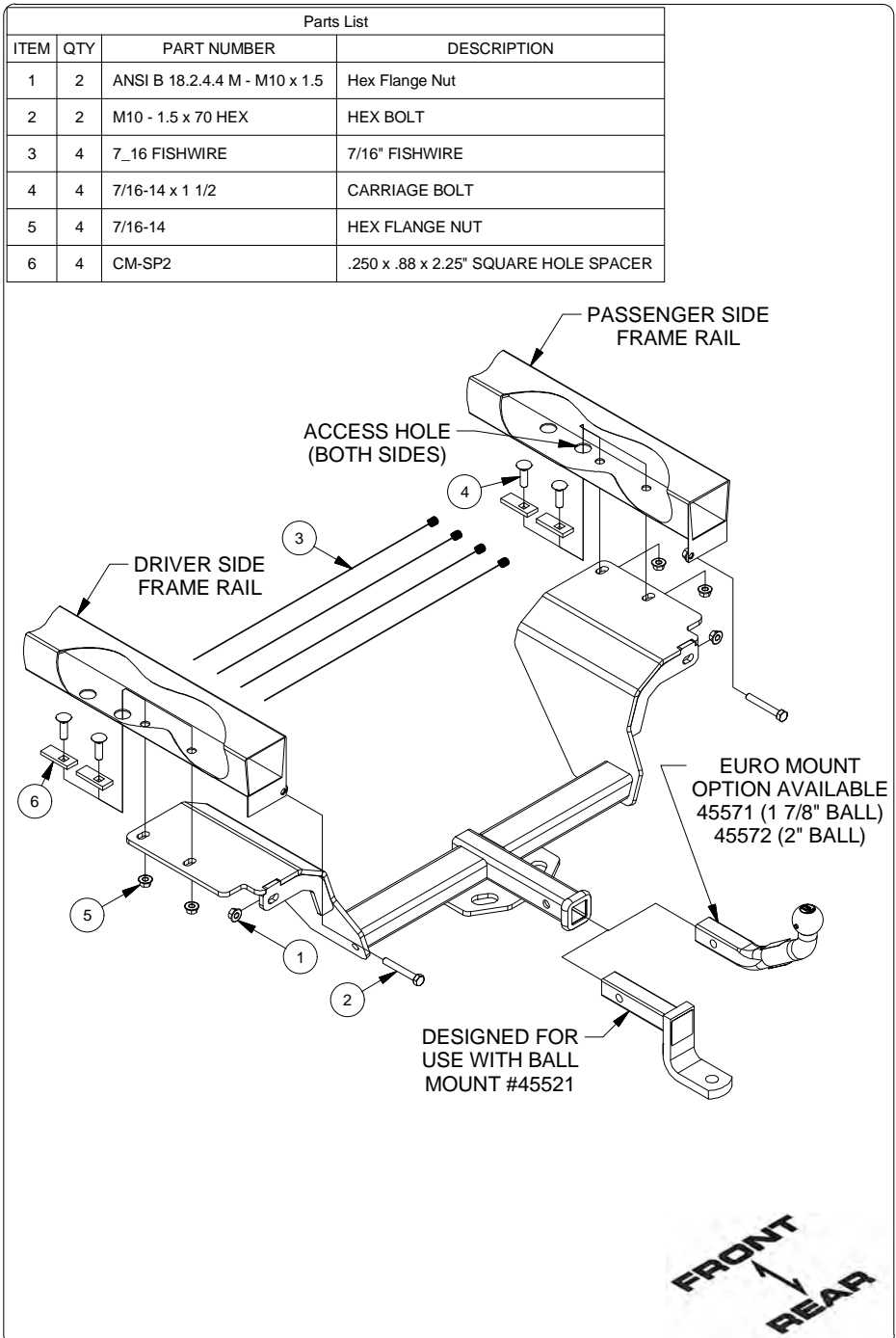

1. Locate and remove exhaust hanger. Support the exhaust and remove (4) M8 bolts for the exhaust brace using a 13mm socket. Remove (2) M8 bolts for the exhaust flange using a 13mm socket. Save the exhaust brace and gasket for later reinstallation.

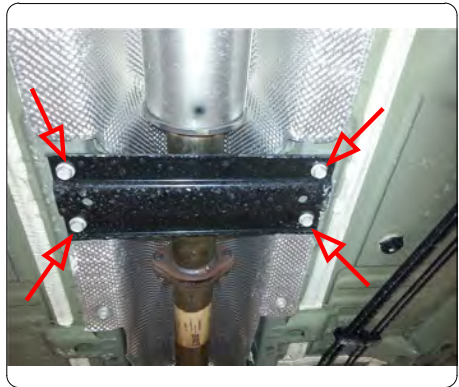

2. Separate exhaust flange and carefully slide the exhaust forward out of the rear bumper exhaust hangers. Set aside exhaust for later reinstallation. Remove the inside lower bumper bolts on each side of the vehicle using a 15mm socket. Replace with the supplied M10 bolts.



INSTALLATION WALKTHROUGH:

3. Locate and remove (10) speed clips, (5) from each side to remove the heat shields. Once removed, mark out and trim a 11" x 4" section using tape and aviation shears. Reinstall heat shields once section has been trimmed.

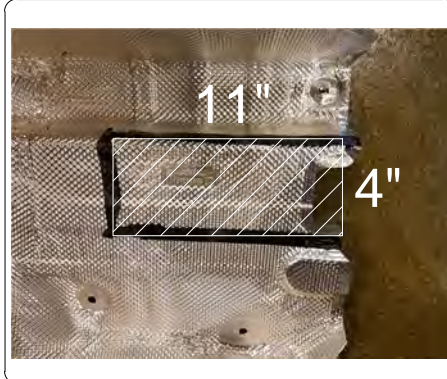

4. Fishwire (2) 7/16" bolts and (2) CM-SP2 spacers from the access hole to the mounting holes on each frame rail. Keep fishwires attached until hitch is raised into position.

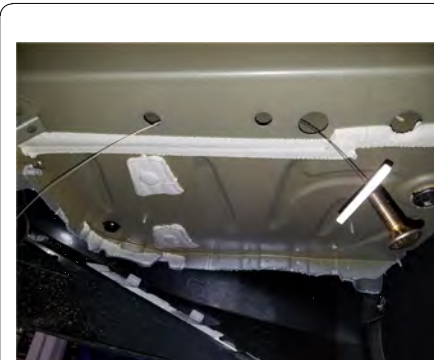

5. Raise the hitch into position, aligning the rear attachment on the M10 bolt. Thread the fishwires into the mounting holes and loosely install (4) 7/16" flange nuts on the frame attachments using a 11/16" socket. Loosely install (2) M10 flange nuts on the inside lower bumper bolts using a 15mm socket.



6. Torque all 7/16" hardware to 60 ft-lbs. Torque all M10 hardware to 45 ft-lbs. Reinstall exhaust and hardware removed in steps (1) and (2) in reverse order.

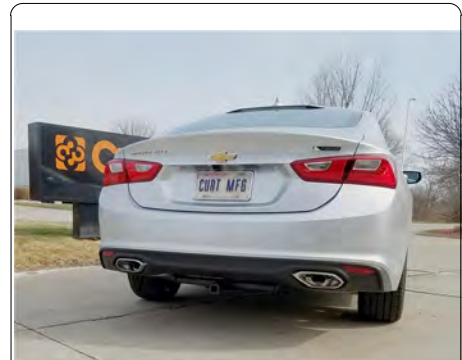

TOWING SAFETY INFORMATION

Gross Trailer Weight / GTW

The Gross Trailer Weight is the weight of the trailer & cargo. Measure this by putting the fully loaded trailer on a vehicle scale.



Tongue Weight / TW

The downward force that is exerted on the hitch ball by the coupler. The tongue weight will vary depending on where the load is positioned in relationship to the trailer axle(s). To measure the tongue weight, use either a commercial scale or a bathroom scale with the coupler at towing height. When using a bathroom scale with heavier tongue weights, use the method shown and multiply the scale reading by 3.

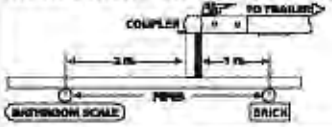

Weight Carrying / WC

The total weight of both the trailer and the cargo inside. Never exceed the weight capacity of your trailer hitch.

Weight Distribution / WD

Used to balance the weight of the cargo between the front and rear wheels throughout the trailer, allowing for better steering, braking, and level riding.



Sway Control

A device used to reduce the lateral movements of the trailer that are caused by the wind. This works in conjunction with a weight distribution hitch. Do not use this on a class 1 or 2 hitch, or with surge brakes.

How Much Can You Safely Tow?

TONGUE WEIGHT (lb)	TRAILER CLASS									
	CLASS 1	CLASS 2	CLASS 3	CLASS 4	CLASS 5	CLASS 6	CLASS 7	CLASS 8	CLASS 9	CLASS 10
1000	1100	1200	1300	1400	1500	1600				
2000										
3000										
4000										
5000										
6000										
7000										
8000										
9000										
10000										

Refer to owner's manual for towing capabilities and limitations.

Ball Mount

The ball mount is placed inside the opening of the receiver hitch which is mounted to the vehicle. Make sure a hitch pin and clip is properly securing the ball mount to the receiver hitch before you begin towing.

• A: Rise. B: Drop. C: Hole Size. D: Length.

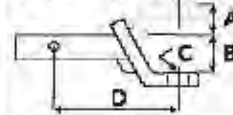

Trailer Ball

The connection from the hitch to the trailer. There are many factors that determine the correct hitch ball:

- Number one is the hitch ball's gross trailer weight rating.
- The mounting platform must be at least 3/8" thick.
- The hole diameter must not be more than 1/16" larger than the threaded shank.
- Every time you tow, check the nut and lock washer to make sure they are fastened securely.

• A: Ball Dia. B: Shank Dia. C: Shank Length. D: Shank Rise.



Coupler

The component that is placed over the trailer ball to connect the vehicle to the trailer. Be sure that the coupler size matches the size of the hitch ball and that the coupler handle is securely fastened. To determine what size hitch ball you need for your application you will need to know the size of coupler that is on the trailer. Be sure your coupler is properly adjusted to the ball you are using.

NOTE: For added security the use of safety devices such as Coupler Safety Pins and Locks is strongly recommended.

Safety Chains

Safety chains are a requirement and should be crossed under the tongue of the trailer so that the tongue will not drop to the road if it becomes separated from the hitch. Always leave enough slack so you can turn. Never allow the safety chains to drag on the ground and never attach the chains to the bumper.

Trailer Classification: Safety Chain Breaking Force - Minimum

Class 1: 2,000 lbs. (8.9 kN)

Class 2: 3,500 lbs. (15.6 kN)

Class 3: 5,000 lbs. (22.2 kN)

The strength rating of each length of safety chain or its equivalent and its attachments shall be equal to or exceed in minimum breaking force the GVWR (Gross Vehicle Weight Rating) of the trailer.

Electrical

Trailer lights, Electric Brakes, Break-away systems - Every time you tow, be sure to check that all components are working properly.

Wiring identification by color:



GROSS LOAD CAPACITY WHEN USED AS A WEIGHT CARRYING HITCH: 3500 LBS. TRAILER WEIGHT & 350 LBS. TONGUE WEIGHT.

WARNING: ALL NON-TRAILER LOADS APPLIED TO THIS PRODUCT MUST BE SUPPORTED BY 18050 STABILIZING STRAPS.

WARNING: ** FAILURE TO PROPERLY SUPPORT NON-TRAILER LOADS WILL VOID PRODUCT WARRANTY **

WARNING: *** DO NOT EXCEED VEHICLE MANUFACTURER'S RECOMMENDED TOWING CAPACITY ***

FOR MORE INFORMATION LOG ONTO WWW.CURTMFG.COM & FOR HELPFUL TOWING TIPS LOG ONTO WWW.HITCHINFO.COM
 HAVING INSTALLATION QUESTIONS? CALL TECHNICAL SUPPORT AT 1-800-798-0813



Parts List			
ITEM	QTY	PART NUMBER	DESCRIPTION
1	2	ANSI B 18.2.4.4 M - M10 x 1.5	Hex Flange Nut
2	2	M10 - 1.5 x 70 HEX	HEX BOLT
3	4	7_16 FISHWIRE	7/16" FISHWIRE
4	4	7/16-14 x 1 1/2	CARRIAGE BOLT
5	4	7/16-14	HEX FLANGE NUT
6	4	CM-SP2	.250 x .88 x 2.25" SQUARE HOLE SPACER

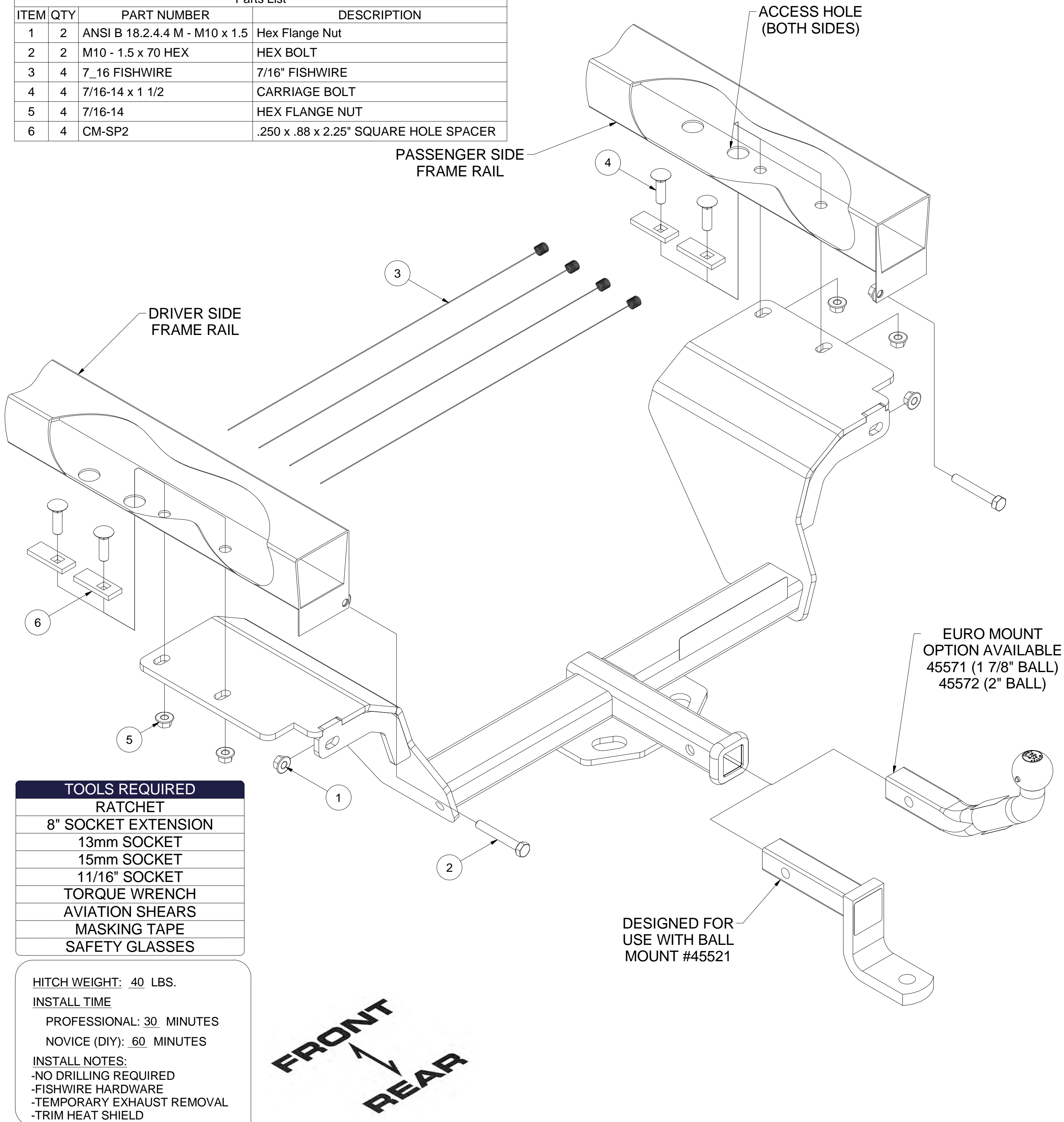

TOOLS REQUIRED
RATCHET
8" SOCKET EXTENSION
13mm SOCKET
15mm SOCKET
11/16" SOCKET
TORQUE WRENCH
AVIATION SHEARS
MASKING TAPE
SAFETY GLASSES

HITCH WEIGHT: 40 LBS.
 INSTALL TIME
 PROFESSIONAL: 30 MINUTES
 NOVICE (DIY): 60 MINUTES
 INSTALL NOTES:
 -NO DRILLING REQUIRED
 -FISHWIRE HARDWARE
 -TEMPORARY EXHAUST REMOVAL
 -TRIM HEAT SHIELD

FRONT
 ↓
REAR

PERIODICALLY CHECK THIS RECEIVER HITCH TO ENSURE THAT ALL FASTENERS ARE TIGHT AND THAT ALL STRUCTURAL COMPONENTS ARE SOUND.



Scan for more information

CURT Manufacturing LLC., warrants this product to be free of defects in material and/or workmanship at the time of retail purchase by the original purchaser. If the product is found to be defective, CURT Manufacturing LLC., may repair or replace the product, at their option, when the product is returned, prepaid, with proof of purchase. Alteration to, misuse of, or improper installation of this product voids the warranty. CURT Manufacturing LLC.'s liability is limited to repair or replacement of products found to be defective, and specifically excludes liability for incidental or consequential loss or damage.

This product complies with safety specifications and requirements for connecting devices and towing systems of the state of New York, V.E.S.C.Regulation V-5 and SAE J684.

HAVING INSTALLATION QUESTIONS? CALL TECHNICAL SUPPORT AT 1-800-798-0813

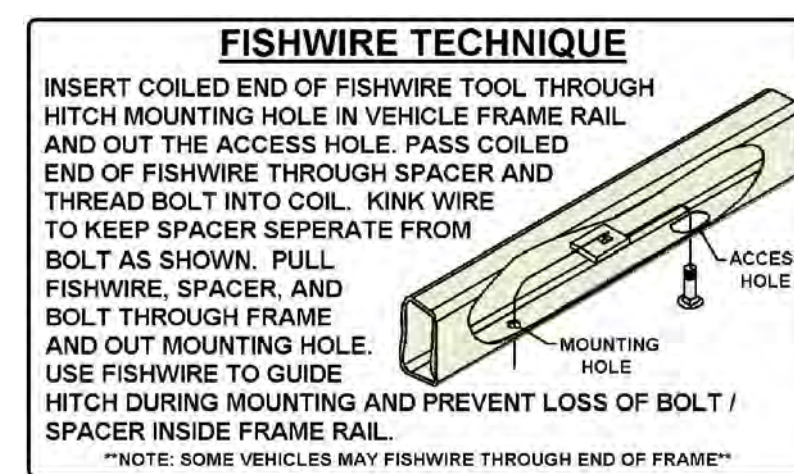
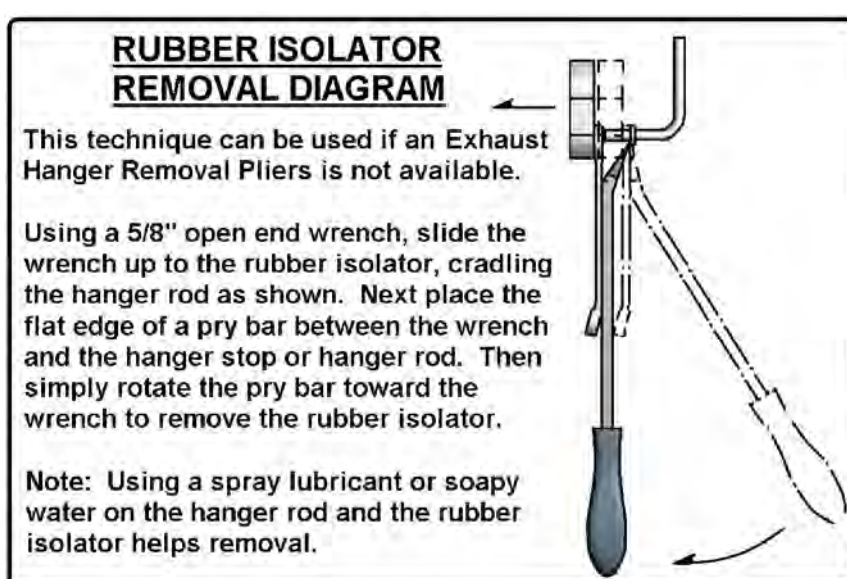
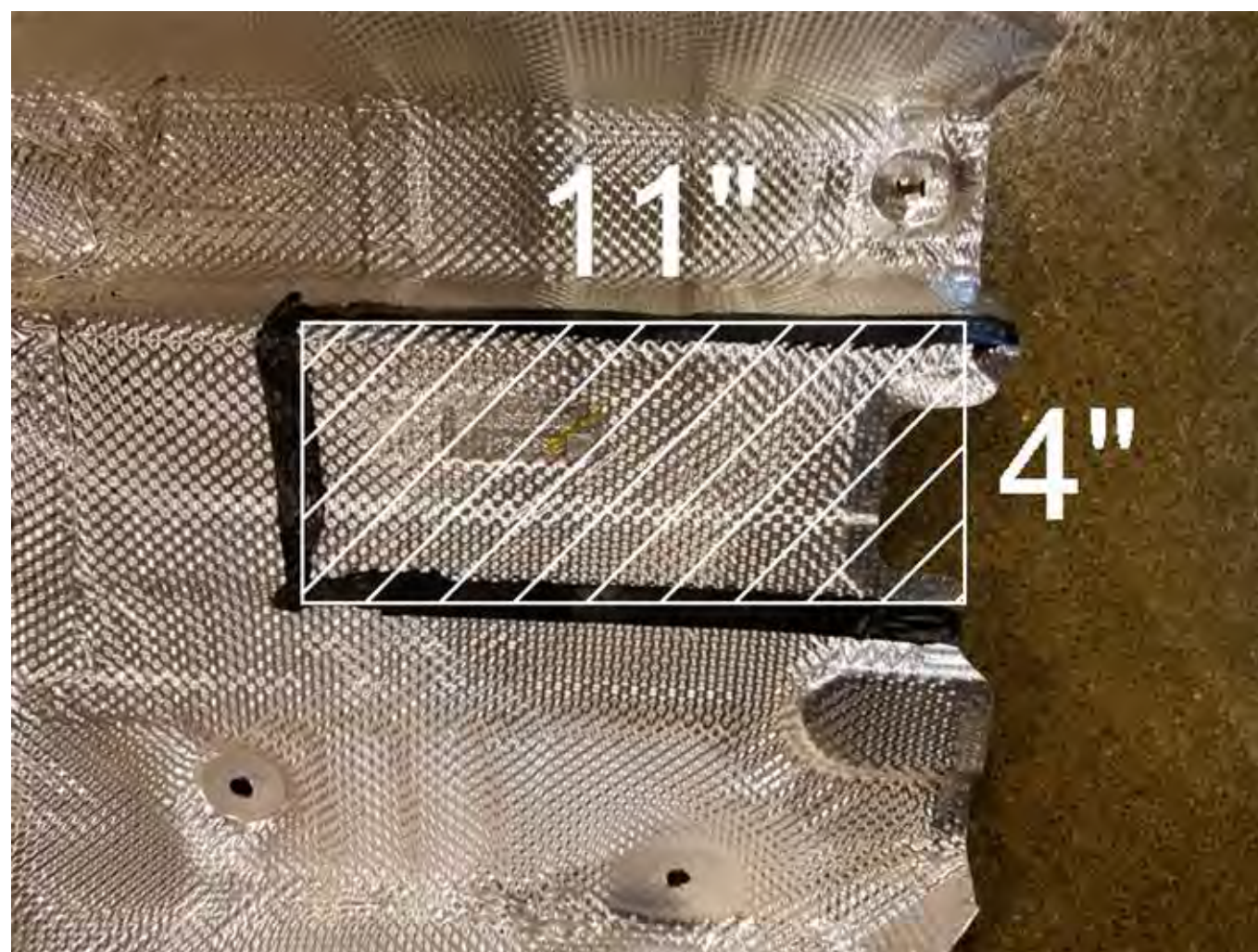

INSTALLATION STEPS

1. Locate and remove exhaust hanger. Support the exhaust and remove (4) M8 bolts for the exhaust brace using a 13mm socket. Remove (2) M8 bolts for the exhaust flange using a 13mm socket. Save the exhaust brace and asket for later reinstallation.
2. Separate exhaust flange and carefully slide the exhaust forward out of the rear bumper exhaust hangers. Set aside exhaust for later reinstallation. Remove the inside lower bumper bolts on each side of the vehicle using a 15mm socket. Replace with the supplied M10 bolts.
3. Locate and remove (10) speed clips, (5) from each side to remove both heat shields. Once removed, mark out and trim a 11" x 4" section using tape and aviation shears. Reinstall heat shields once sections have been trimmed.
4. Fishwire (2) 7/16" bolts and (2) CM-SP2 spacers from the access hole to the mounting holes on each frame rail. Keep fishwires attached until hitch is raised into position.
5. Raise the hitch into position, aligning the rear attachment on the M10 bolt. Thread the fishwires into the mounting holes. Loosely install (4) 7/16" flange nuts on the frame attachments using a 11/16" socket. Loosely install (2) M10 flange nuts on the inside lower bumper bolts using a 15mm socket.
6. Torque all 7/16" hardware to 60 ft-lbs. Torque all M10 hardware to 45 ft-lbs. Reinstall exhaust and hardware removed in steps (1) and (2) in reverse order.

PERIODICALLY CHECK THIS RECEIVER HITCH TO ENSURE THAT ALL FASTENERS ARE TIGHT AND THAT ALL STRUCTURAL COMPONENTS ARE SOUND.

CURT Manufacturing LLC., warrants this product to be free of defects in material and/or workmanship at the time of retail purchase by the original purchaser. If the product is found to be defective, CURT Manufacturing LLC., may repair or replace the product, at their option, when the product is returned, prepaid, with proof of purchase. Alteration to, misuse of, or improper installation of this product voids the warranty. CURT Manufacturing LLC.'s liability is limited to repair or replacement of products found to be defective, and specifically excludes liability for incidental or consequential loss or damage.

This product complies with safety specifications and requirements for connecting devices and towing systems of the state of New York, V.E.S.C.Regulation V-5 and SAE J684.