

**12199****1997-2003 PONTIAC GRAND PRIX SE****7/22/2014****GROSS LOAD CAPACITY WHEN USED AS A WEIGHT CARRYING HITCH: 3,500 LBS. TRAILER WEIGHT & 350 LBS. TONGUE WEIGHT.**

\*\*\*DO NOT EXCEED VEHICLE MANUFACTURER'S RECOMMENDED TOWING CAPACITY.\*\*\*

**WARNING: ALL NON-TRAILER LOADS APPLIED TO THIS PRODUCT MUST BE SUPPORTED BY 18050 STABILIZING STRAPS.**

\*\* FAILURE TO PROPERLY SUPPORT NON-TRAILER LOADS WILL VOID PRODUCT WARRANTY\*\*

**HAVING INSTALLATION QUESTIONS? CALL TECHNICAL SUPPORT AT 1-800-798-0813**

Parts List			
ITEM	QTY	PART NUMBER	DESCRIPTION
1	4	FW12	FW, 12, ZP
2	2	1/2"	LOCK WASHER
3	2	1/2-13	HANDLE NUT
4	4	CM-SP1	.250 x 1.50 x 2.00" SQUARE HOLE SPACER
5	4	1/2-13 x 1 1/4	CARRIAGE BOLT
6	4	HFN 1213	HEX FLANGE NUT
7	2	1/2-13 x 1 1/4	HEX BOLT

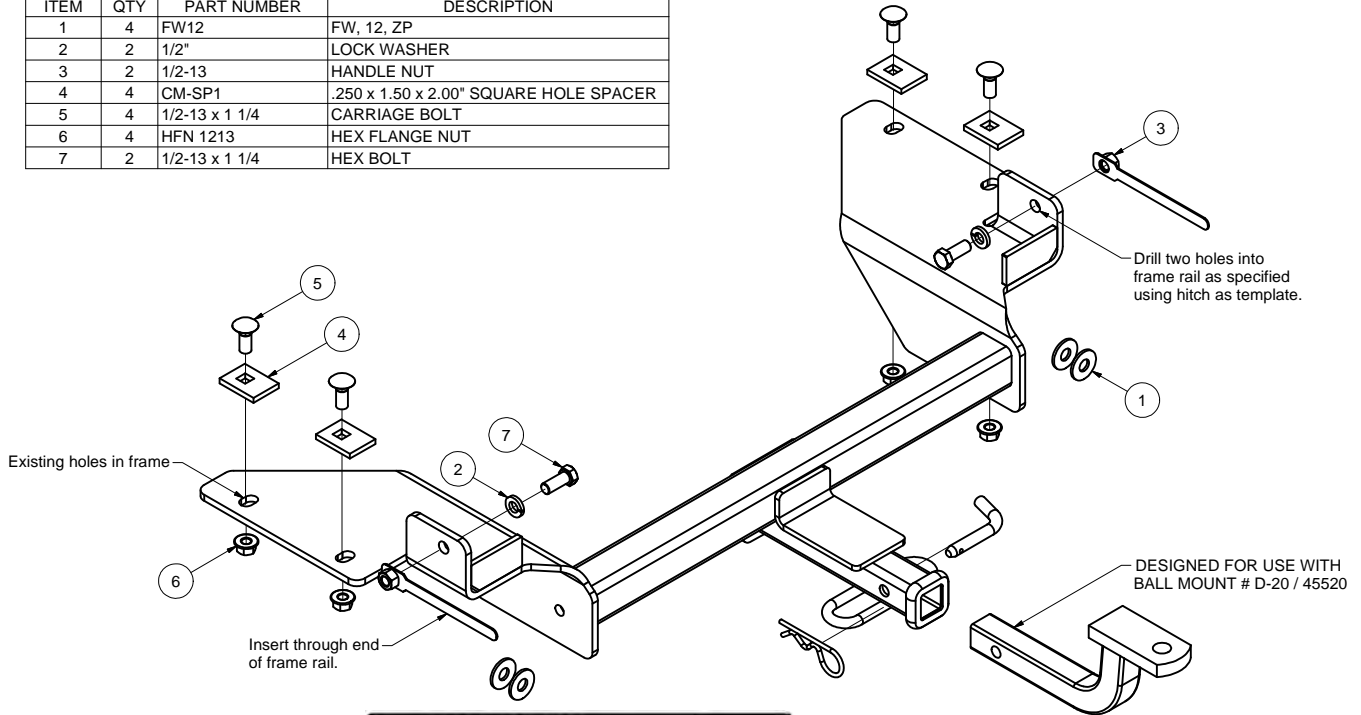
**RUBBER ISOLATOR  
REMOVAL DIAGRAM**

This technique can be used if and Exhaust Hanger Removal Pliers is not available.

Using a 5/8" open end wrench, slide the wrench up to the rubber isolator, cradling the hanger rod as shown. Next place the flat edge of a pry bar between the wrench and the hanger stop or hanger rod. Then simply rotate the pry bar toward the wrench to remove the rubber isolator.

Note: Using a spray lubricant or soapy water on the hanger rod and the rubber isolator helps removal.

**HITCH WEIGHT: 40 LBS.****INSTALL TIME**

PROFESSIONAL: 45 MINUTES

NOVICE (DIY): 90 MINUTES

**INSTALL NOTES:**

DRILLING REQUIRED

**INSTALLATION STEPS**

- 1) Detach (5) rubber exhaust hangers and lower rearward portion of exhaust system.
- 2) Insert carriage bolts and blocks in frame rails through access hole.
- 3) Raise hitch into position and check side to side clearance with frame. Tape 1/2" washers to hitch as necessary to eliminate gap.
- 4) Raise hitch into position and attach with carriage bolts as shown.
- 5) Using hitch as a template, drill two holes in side of frame rails.
- 6) Insert hex bolt and lock washer through side of frame rail and secure with handle nut inserted through end of frame rail.
- 7) Reinstall exhaust system.
- 8) Torque all 1/2" fasteners to 110 lb.-ft.

PERIODICALLY CHECK THIS RECEIVER HITCH TO ENSURE THAT ALL FASTENERS ARE TIGHT AND THAT ALL STRUCTURAL COMPONENTS ARE SOUND.

Curt Manufacturing Inc., warrants this product to be free of defects in material and/or workmanship at the time of retail purchase by the original purchaser. If the product is found to be defective, Curt Manufacturing Inc., may repair or replace the product, at their option, when the product is returned, prepaid, with proof of purchase. Alteration to, misuse of, or improper installation of this product voids the warranty. Curt Manufacturing Inc.'s liability is limited to repair or replacement of products found to be defective, and specifically excludes liability for incidental or consequential loss or damage.